

| FORD SERVICE

Rettungsdatenblätter



Impressum

Diese Rettungsblätter wurden entwickelt, um geschulte Rettungskräfte bei der Unfallhilfe an Ford-Fahrzeugen aus der Europäischen Union zu unterstützen.

Die Informationen in dieser Veröffentlichung entsprechen dem Wissensstand zur Zeit der Drucklegung.

Im Hinblick auf weitere Entwicklungen behalten wir uns das Recht vor, Spezifikationen, Design oder Ausstattung jederzeit ohne Vorankündigung und ohne Verpflichtungen zu ändern.

Diese Veröffentlichung darf weder als Ganzes noch in Teilen ohne vorherige schriftliche Genehmigung durch uns reproduziert, weitergeleitet, in einem Datenverarbeitungssystem gespeichert oder in eine andere Sprache übersetzt werden.

Fehler und Auslassungen sind ausgenommen.

Alle Rechte vorbehalten.

(Stand : 11/2019)



FORD SERVICE

Rettungsdatenblätter

Modelbezeichnung	Baujahr
B	
B-MAX	08/2012 – >
B-MAX - LPG	03/2013 – >
C	
C-MAX	06/2003 – 10/2007
C-MAX	10/2007 – 12/2010
C-MAX	11/2010 – 03/2015
C-MAX - LPG	06/2003 – 10/2007
C-MAX - LPG	10/2007 – 12/2010
C-MAX - CNG	06/2003 – 10/2007
C-MAX - CNG	10/2007 – 12/2010
C-MAX (Grand MAV (5+2-Sitzer))	11/2010 – 03/2015
C-MAX (Grand MAV (5+2-Sitzer))	03/2015 – >
C-MAX (Kompakt-MAV (5-Sitzer))	03/2015 – >
C-MAX - LPG (Kompakt-MAV (5-Sitzer))	06/2012 – 03/2015
C-MAX - LPG (Kompakt-MAV (5-Sitzer))	03/2015 – >
C-MAX E=NERGI - HEV	10/2014 – >
E	
Eco Sport	09/2013 – >
Edge	06/2018 – >
Edge (5-Türer SUV)	10/2015 – >
F	
Fiesta	01/1996 – 02/2000
Fiesta	02/2000 – 02/2002
Fiesta (3-Türer)	06/2008 – 04/2017
Fiesta (3-Türer)	11/2001 – 09/2008
Fiesta (3-Türer)	04/2017 – >
Fiesta - LPG (3-Türer)	06/2008 – 04/2017
Fiesta (5-Türer)	11/2001 – 09/2008
Fiesta (5-Türer)	06/2008 – 04/2017
Fiesta (5-Türer)	04/2017 – >
Fiesta - LPG (5-Türer)	06/2008 – 04/2017
Focus (3-Türer)	07/2004 – 08/2007
Focus (3-Türer)	08/2007 – 03/2011
Focus (3-Türer)	08/1998 – 12/2004

Modelbezeichnung	Baujahr
Focus - LPG (3-Türer)	08/2007 – 03/2011
Focus - LPG (3-Türer)	07/2004 – 08/2007
Focus - CNG (3-Türer)	07/2004 – 08/2007
Focus - CNG (3-Türer)	08/2007 – 03/2011
Focus (4-Türer)	07/2004 – 08/2007
Focus (4-Türer)	08/1998 – 12/2004
Focus (4-Türer)	08/2007 – 03/2011
Focus (4-Türer)	03/2011 – 09/2014
Focus (4-Türer)	09/2014 – 04/2018
Focus (4-Türer)	04/2018 – >
Focus (5-Türer)	08/2007 – 03/2011
Focus (5-Türer)	08/1998 – 12/2004
Focus (5-Türer)	03/2011 – 09/2014
Focus (5-Türer)	07/2004 – 08/2007
Focus (5-Türer)	09/2014 – 04/2018
Focus (5-Türer)	04/2018 – >
Focus - LPG (5-Türer)	08/2007 – 03/2011
Focus - LPG (5-Türer)	07/2004 – 08/2007
Focus - LPG (5-Türer)	05/2012 – 09/2014
Focus - LPG (5-Türer)	09/2014 – 04/2018
Focus - CNG (5-Türer)	08/2007 – 03/2011
Focus - CNG (5-Türer)	07/2004 – 08/2007
Focus (Cabrio)	03/2007 – 07/2010
Focus (Turnier)	07/2004 – 08/2007
Focus (Turnier)	08/2007 – 03/2011
Focus (Turnier)	08/1998 – 12/2004
Focus (Turnier)	03/2011 – 09/2014
Focus (Turnier)	09/2014 – 04/2018



FORD SERVICE

Rettungsdatenblätter

Modelbezeichnung	Baujahr
Focus (Turnier)	04/2018 – >
Focus - LPG (Turnier)	08/2007 – 03/2011
Focus - LPG (Turnier)	07/2004 – 08/2007
Focus - LPG (Turnier)	05/2012 – 09/2014
Focus - LPG (Turnier)	09/2014 – 04/2018
Focus E=LECTRIC	
Fusion	06/2002 – >
G	
Galaxy	02/2006 – 05/2015
Galaxy	04/2000 – 02/2006
Galaxy (5-Türer LMV)	05/2015 – >
GT	12/2017 – >
K	
KA	08/2008 – >
KA	09/1996 – 07/2008
Ka+	05/2016 – >
Kuga	02/2008 – 10/2012
Kuga	10/2012 – >
M	
Mondeo (4-Türer)	10/2000 – 02/2007
Mondeo (4-Türer)	02/2007 – 09/2014
Mondeo - LPG (4-Türer)	02/2007 – 09/2014
Mondeo (5-Türer)	10/2000 – 02/2007
Mondeo (5-Türer)	02/2007 – 09/2014
Mondeo (5-Türer)	09/2014 – >
Mondeo - LPG (5-Türer)	02/2007 – 09/2014
Mondeo (Turnier)	10/2000 – 02/2007
Mondeo (Turnier)	02/2007 – 09/2014
Mondeo (Turnier)	09/2014 – >
Mondeo - LPG (Turnier)	02/2007 – 09/2014
Mondeo "Hybrid" - HEV (4-Türer)	10/2014 – >
Mustang (Cabrio)	03/2015 – >
Mustang (Coupé)	03/2015 – >

Modelbezeichnung	Baujahr
P	
Puma	10/2019 – >
Puma mHEV (1.0L EcoBoost (92kW/125PS) (B7), 1.0L EcoBoost (114kW/155PS) (BZ))	
Puma mHEV (1.0L EcoBoost (92kW/125PS) (B7), 1.0L EcoBoost (114kW/155PS) (BZ))	04/2020 – >
R	
Ranger	06/2006 – 07/2011
Ranger	07/2011 – >
S	
S-MAX	02/2006 – 05/2015
S-MAX (5-Türer SAV)	05/2015 – >
Streetka (Cabrio)	01/2003 – 07/2005
T	
Tourneo Connect	09/2013 – >
Tourneo Connect	06/2002 – 07/2013
Tourneo Courier	03/2014 – >
Tourneo Custom	07/2012 – >
Transit 2014.5 (M2 Bus)	08/2013 – >
Transit 2014.5 (Einzelkabine ohne Aufbau)	08/2013 – >
Transit 2014.5 (Doppelkabine ohne Aufbau)	08/2013 – >
Transit 2014.5 (Kastenwagen)	08/2013 – >
Transit 2014.5 (N1 Kombi)	08/2013 – >
Transit Connect (Kastenwagen mit langem Radstand)	02/2013 – >
Transit Courier	
Transit Custom	07/2012 – >
Transit Tourneo	08/2007 – >

(Stand : 11/2019)



FORD B-MAX



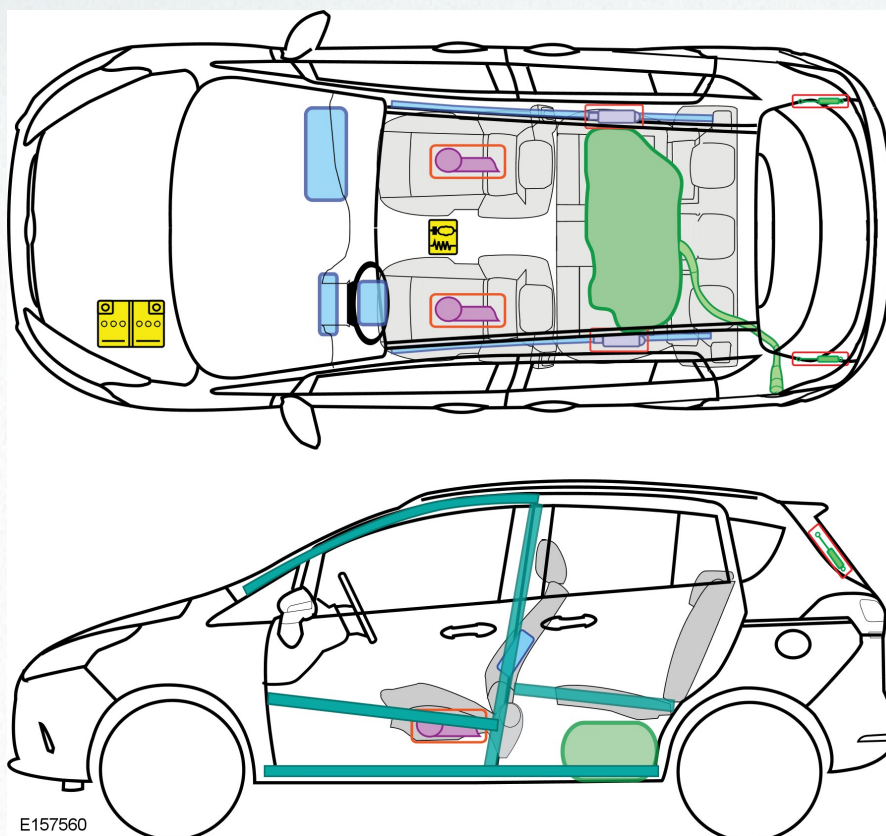



08/2012 – >

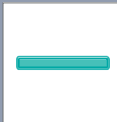

E157560

Legende

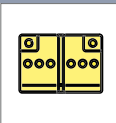
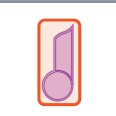
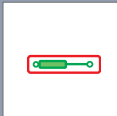
B

	Airbag		Karosseriever- stärkung		Steuergerät		Fussgänger- schutzsystem
	Gasgenerator		Überrollschutz- bügel		Batterie		
	Gurtstraffer		Gasdruck- dämpfer		Kraftstofftank		

(Stand : 10/2012)

FORD B-MAX - LPG

03/2013 – >



E157559

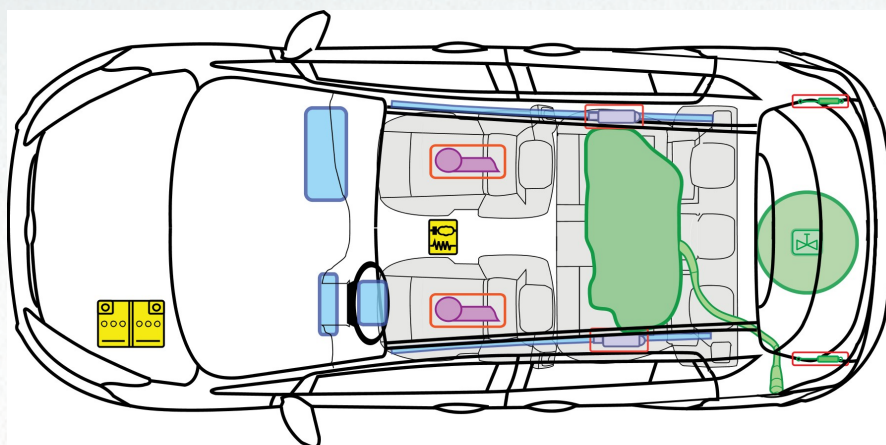



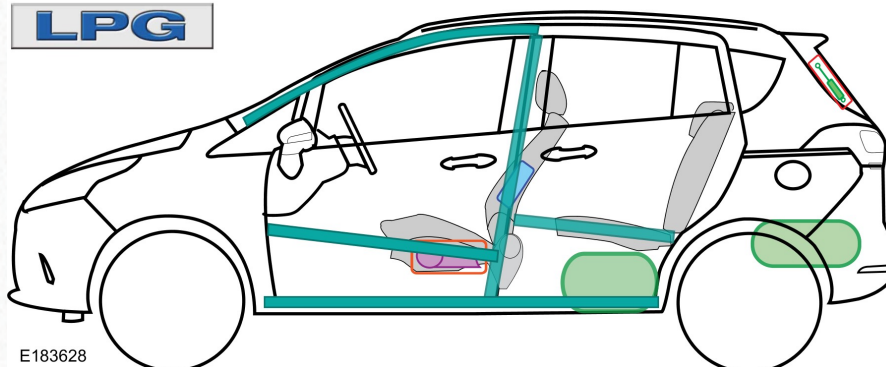





LPG

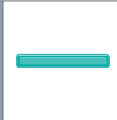

E183628

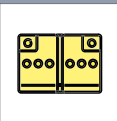
Legende

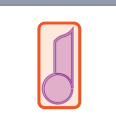
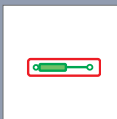
B

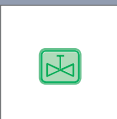
	Airbag		Karosseriever- stärkung		Steuergerät		Fussgänger- schutzsystem
	Gasgenerator		Überrollschutz- bügel		Batterie		Gastank
	Gurtstraffer		Gasdruck- dämpfer		Kraftstofftank		Sicherheits- ventil

(Stand : 04/2014)

FORD C-MAX

06/2003 – 10/2007





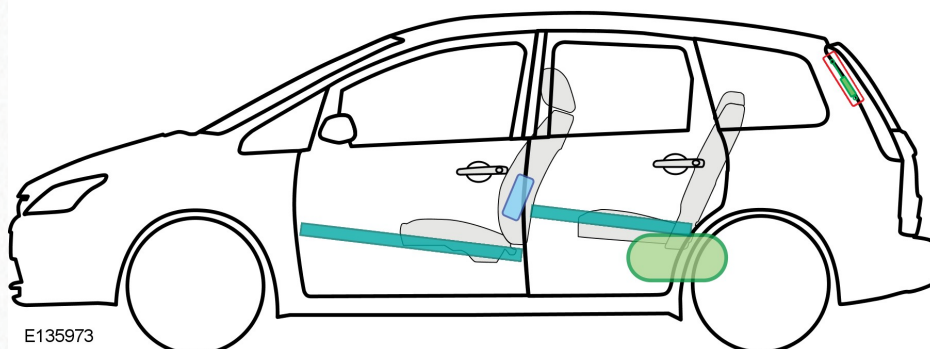
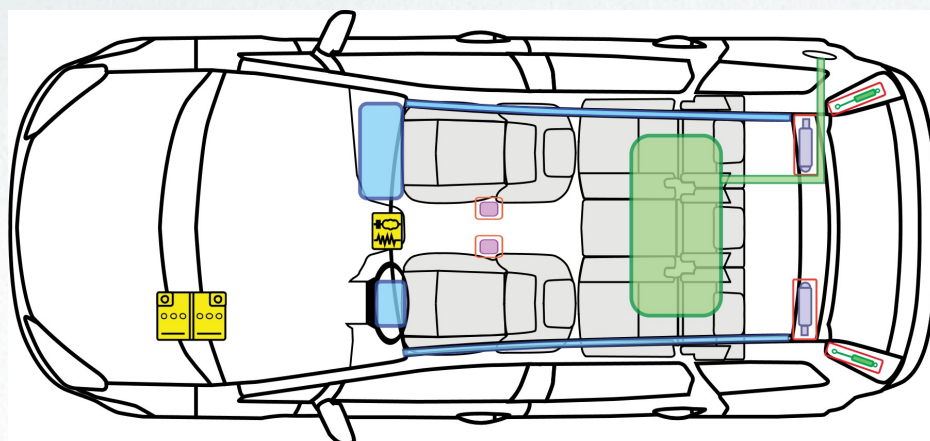



E135972

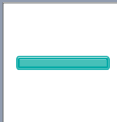
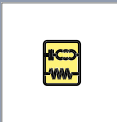

E135973

Legende

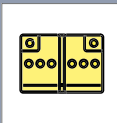
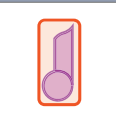
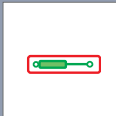
C

	Airbag		Karosseriever- stärkung		Steuergerät		Fussgänger- schutzsystem
	Gasgenerator		Überrollschutz- bügel		Batterie		
	Gurtstraffer		Gasdruck- dämpfer		Kraftstofftank		

(Stand : 03/2011)

FORD C-MAX

10/2007 – 12/2010





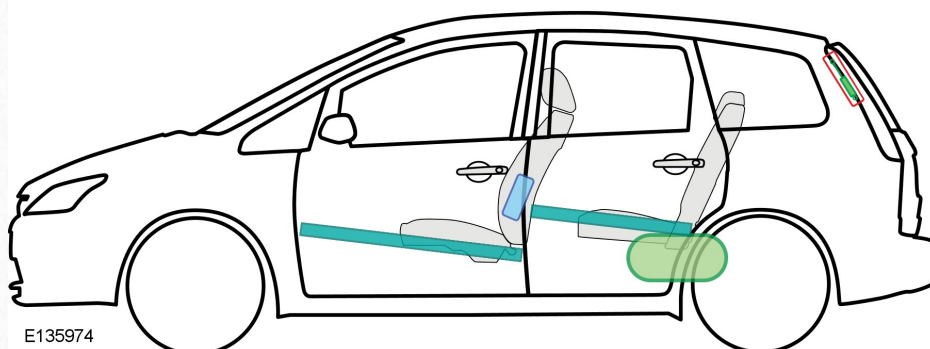
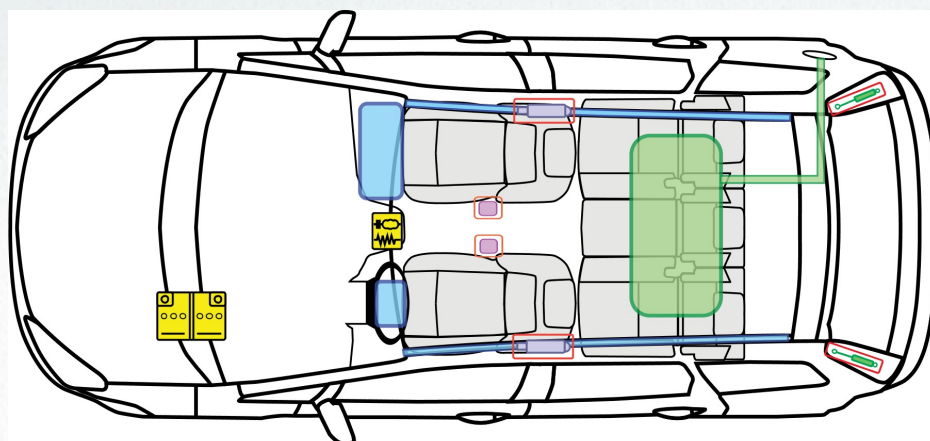

E135972

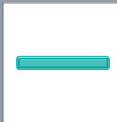
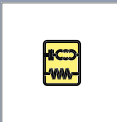

E135974

Legende

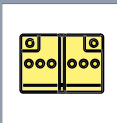
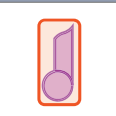
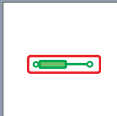
C

	Airbag		Karosseriever- stärkung		Steuergerät		Fussgänger- schutzsystem
	Gasgenerator		Überrollschutz- bügel		Batterie		
	Gurtstraffer		Gasdruck- dämpfer		Kraftstofftank		

(Stand : 03/2011)

FORD C-MAX

11/2010 – 03/2015

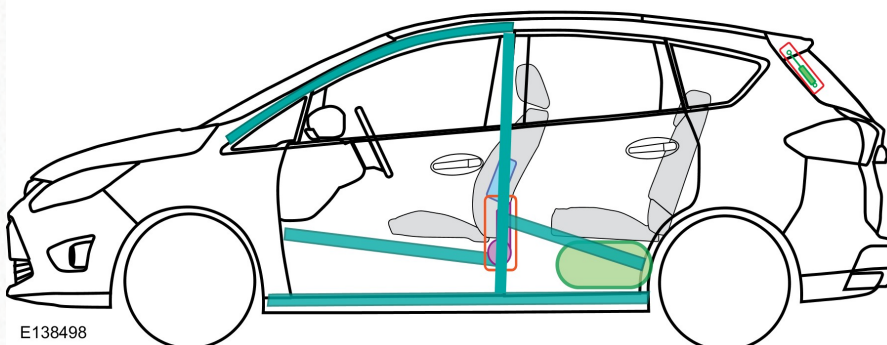
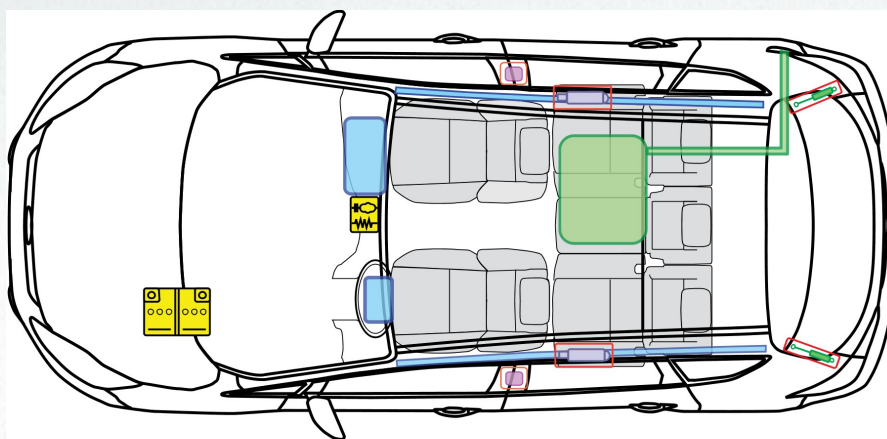

E138498

Legende

C

	Airbag		Karosseriever- stärkung		Steuergerät		Fussgänger- schutzsystem
	Gasgenerator		Überrollschutz- bügel		Batterie		
	Gurtstraffer		Gasdruck- dämpfer		Kraftstofftank		

(Stand : 10/2012)





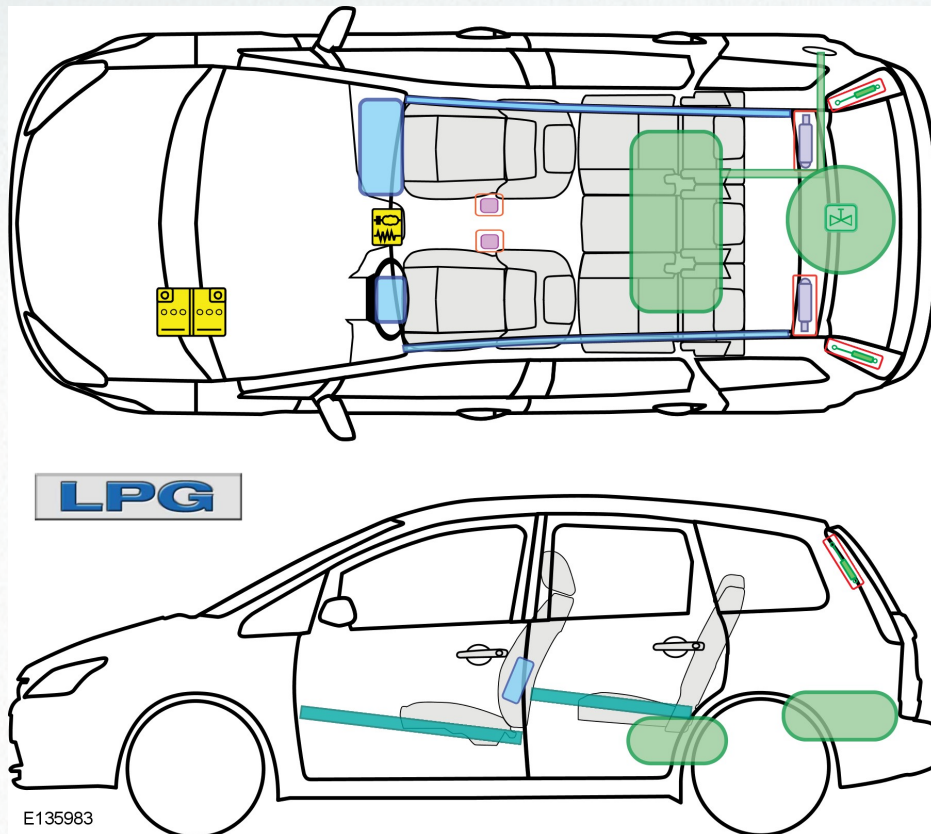

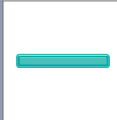

FORD C-MAX - LPG

06/2003 – 10/2007

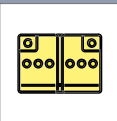

Legende

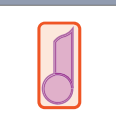
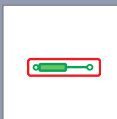
C

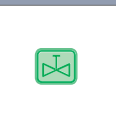
	Airbag		Karosseriever- stärkung		Steuergerät		Fussgänger- schutzsystem
	Gasgenerator		Überrollschutz- bügel		Batterie		Gastank
	Gurtstraffer		Gasdruck- dämpfer		Kraftstofftank		Sicherheits- ventil

(Stand : 08/2013)





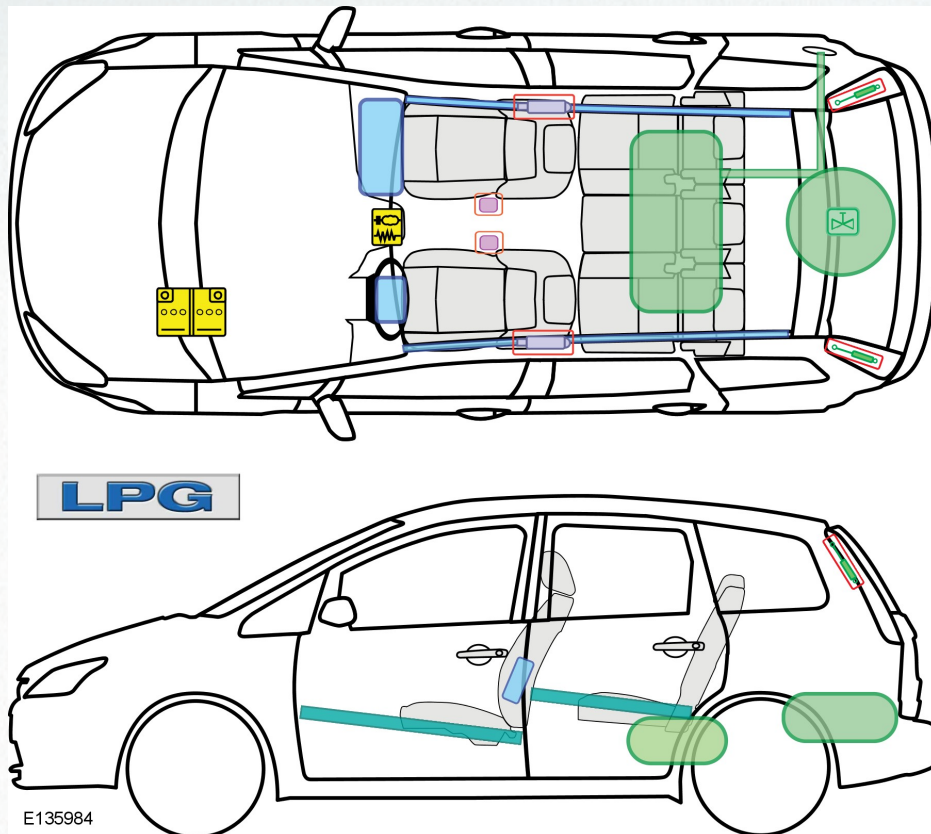

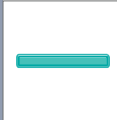

FORD C-MAX - LPG

10/2007 – 12/2010

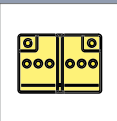

Legende

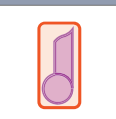
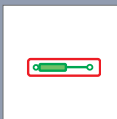
C

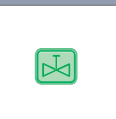
	Airbag		Karosseriever- stärkung		Steuergerät		Fussgänger- schutzsystem
	Gasgenerator		Überrollschutz- bügel		Batterie		Gastank
	Gurtstraffer		Gasdruck- dämpfer		Kraftstofftank		Sicherheits- ventil

(Stand : 08/2013)

FORD C-MAX - CNG

06/2003 – 10/2007

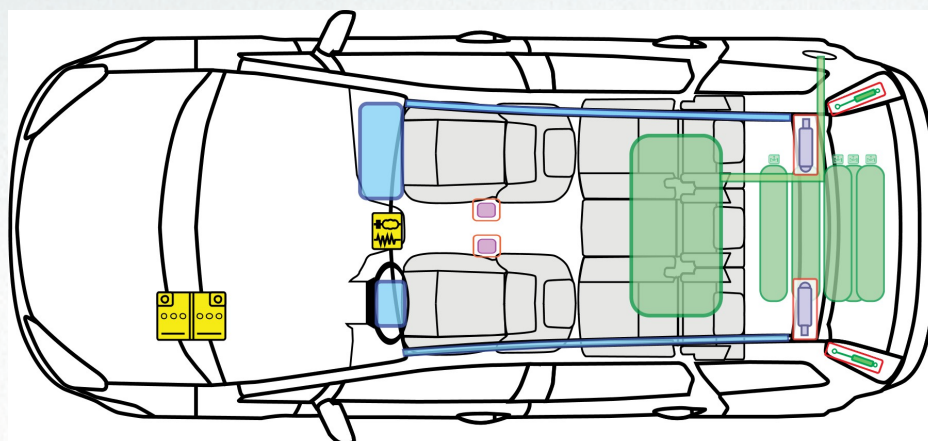



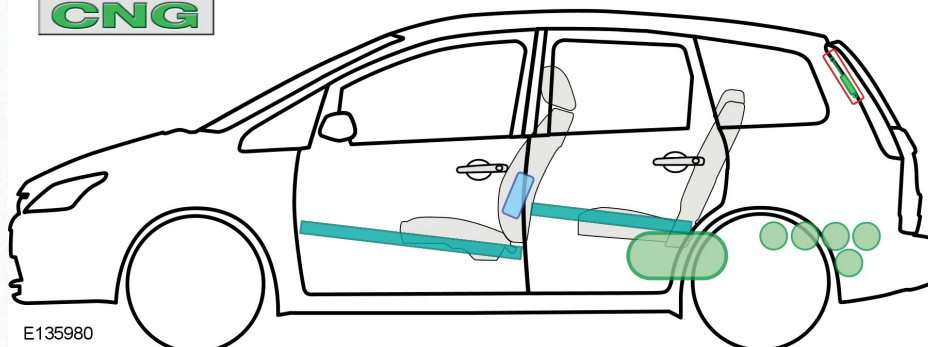





CNG

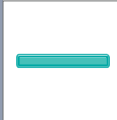

E135980

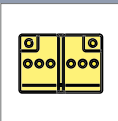
Legende

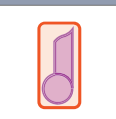
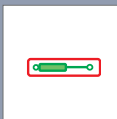
C

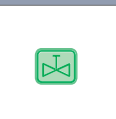
	Airbag		Karosseriever- stärkung		Steuergerät		Fussgänger- schutzsystem
	Gasgenerator		Überrollschutz- bügel		Batterie		Gastank
	Gurtstraffer		Gasdruck- dämpfer		Kraftstofftank		Sicherheits- ventil

(Stand : 07/2013)

FORD C-MAX - CNG

10/2007 – 12/2010



E135972

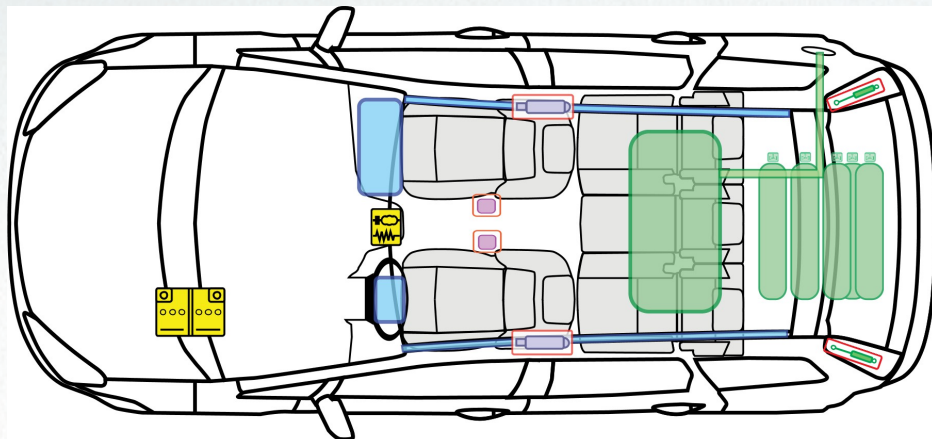

CNG

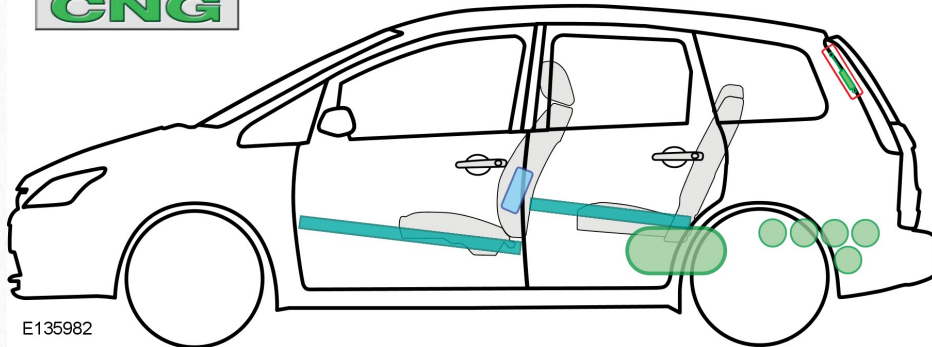

E135982

Legende

C

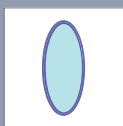

Airbag

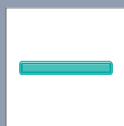

Karosseriever-
stärkung



Steuergerät



Fussgänger-
schutzsystem



Gasgenerator



Überrollschutz-
bügel

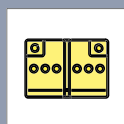

Batterie



Gastank

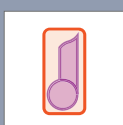

Gurtstraffer

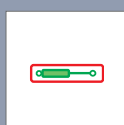

Gasdruck-
dämpfer



Kraftstofftank



Sicherheits-
ventil

(Stand : 07/2013)

FORD C-MAX

Grand MAV (5+2-Sitzer)

11/2010 – 03/2015

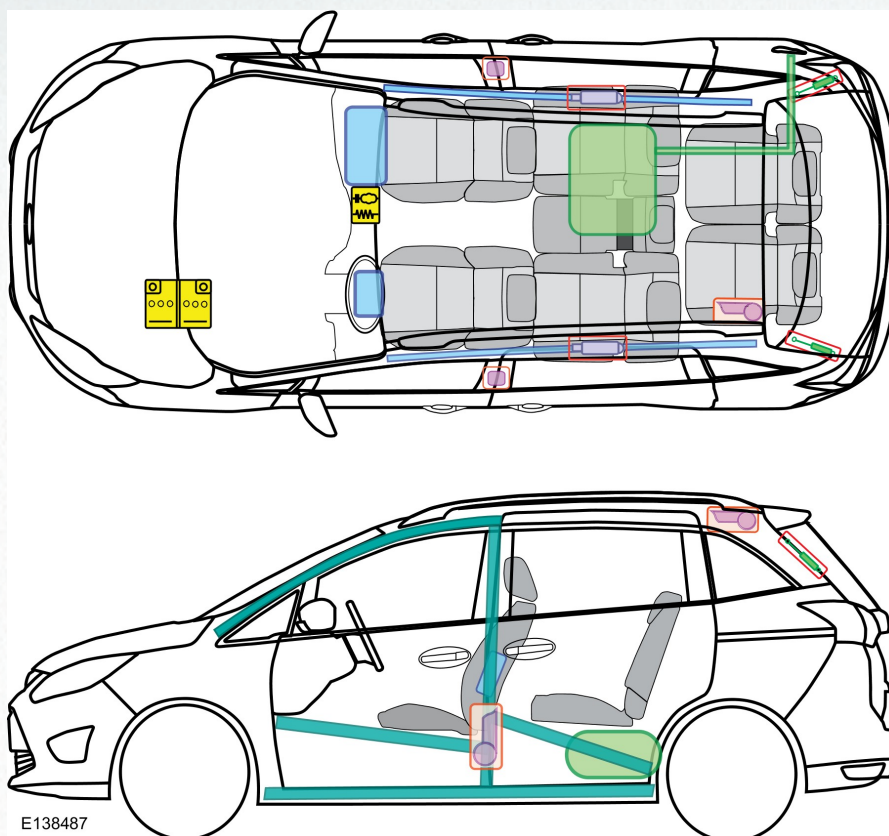

E138487

Legende

C

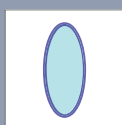

Airbag

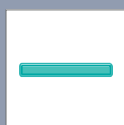

Karosseriever-
stärkung



Steuergerät



Fussgänger-
schutzsystem



Gasgenerator



Überrollschutz-
bügel

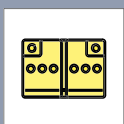

Batterie

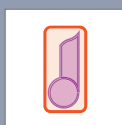

Gurtstraffer

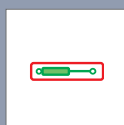

Gasdruck-
dämpfer



Kraftstofftank

(Stand : 08/2012)

FORD C-MAX

Grand MAV (5+2-Sitzer)

03/2015 – >

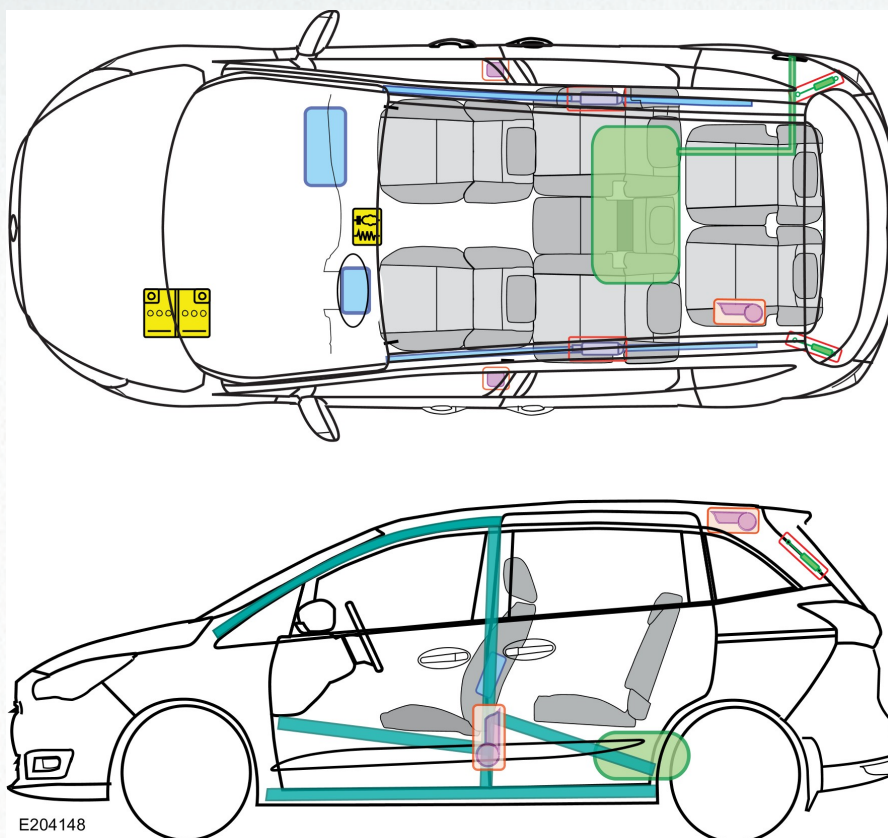

E204148

Legende

C

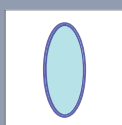

Airbag

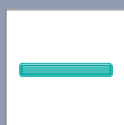

Karosseriever-
stärkung



Steuergerät



Fussgänger-
schutzsystem



Gasgenerator



Überrollschutz-
bügel

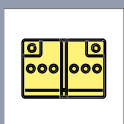

Batterie

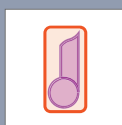

Gurtstraffer

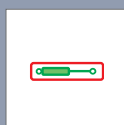

Gasdruck-
dämpfer



Kraftstofftank

(Stand : 02/2017)

FORD C-MAX





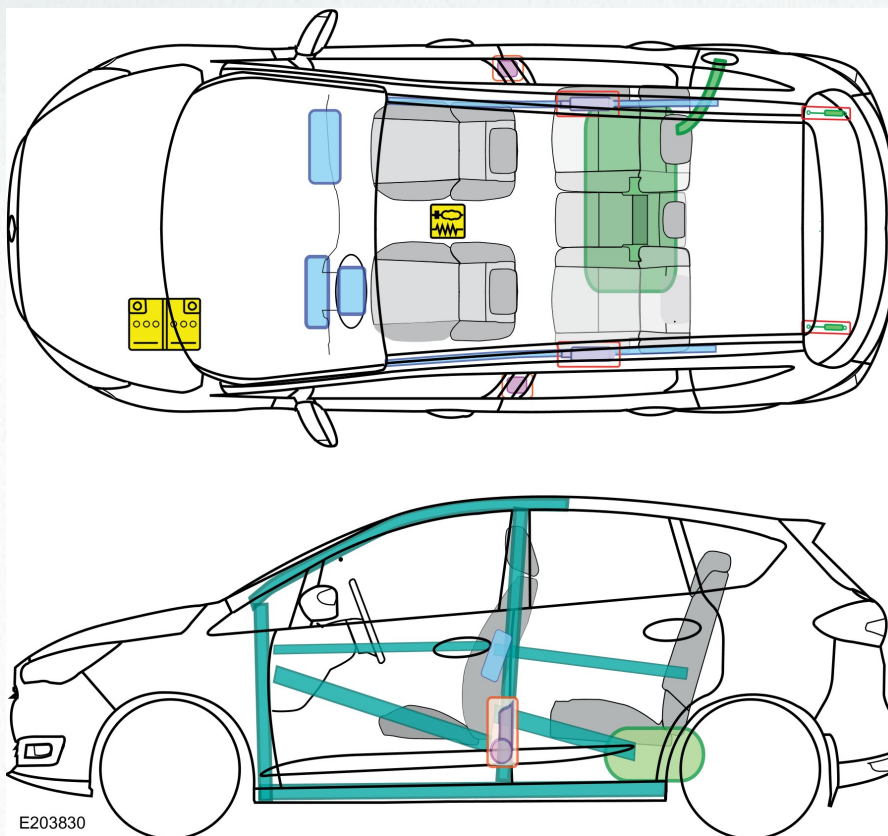

Kompakt-MAV (5-Sitzer)

03/2015 – >

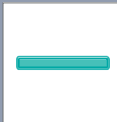

Legende

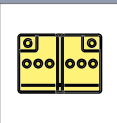
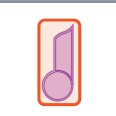
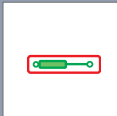
C

	Airbag		Karosseriever- stärkung		Steuergerät		Fussgänger- schutzsystem
	Gasgenerator		Überrollschutz- bügel		Batterie		
	Gurtstraffer		Gasdruck- dämpfer		Kraftstofftank		

(Stand : 07/2015)

FORD C-MAX - LPG

Kompakt-MAV (5-Sitzer)

06/2012 – 03/2015

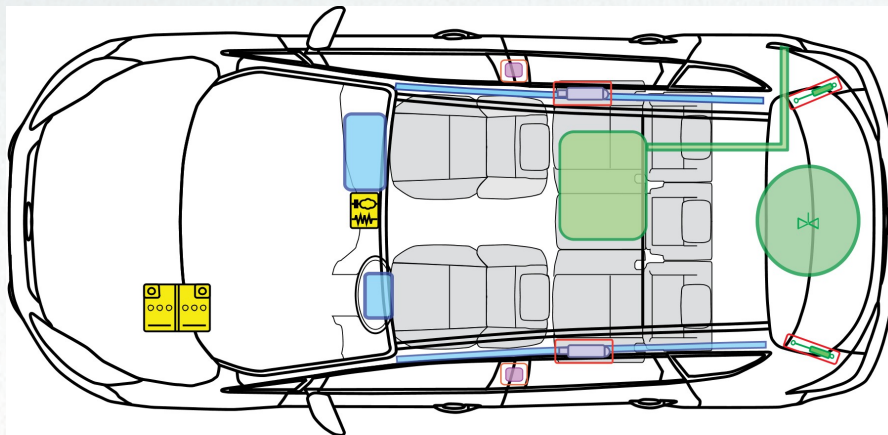



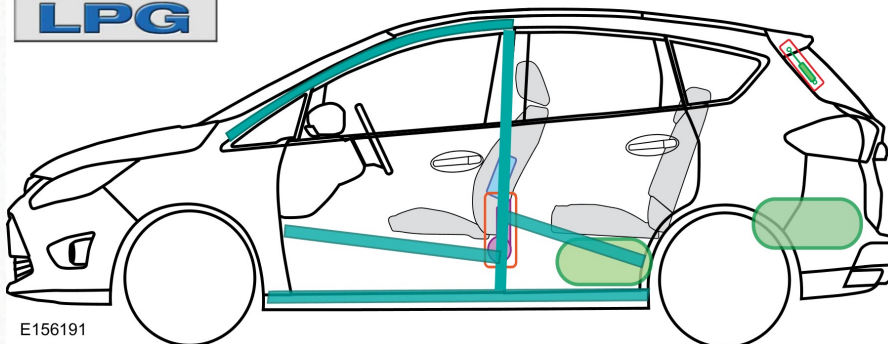





LPG

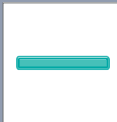

E156191

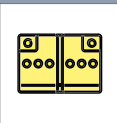
Legende

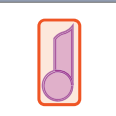
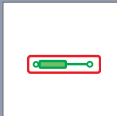
C

	Airbag		Karosseriever- stärkung		Steuergerät		Fussgänger- schutzsystem
	Gasgenerator		Überrollschutz- bügel		Batterie		Gastank
	Gurtstraffer		Gasdruck- dämpfer		Kraftstofftank		Sicherheits- ventil

(Stand : 10/2012)

FORD C-MAX - LPG

Kompakt-MAV (5-Sitzer)



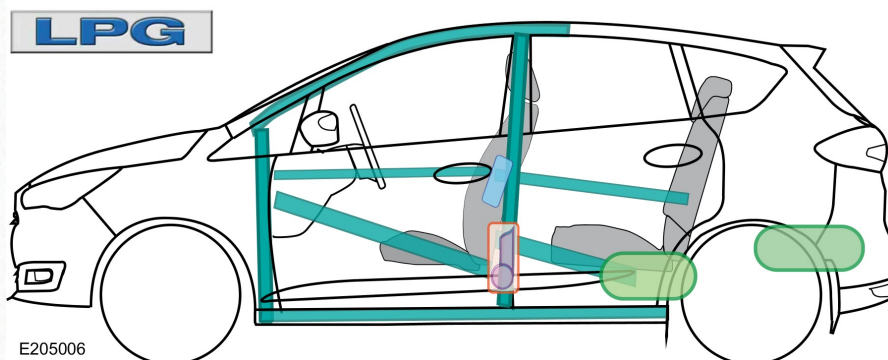
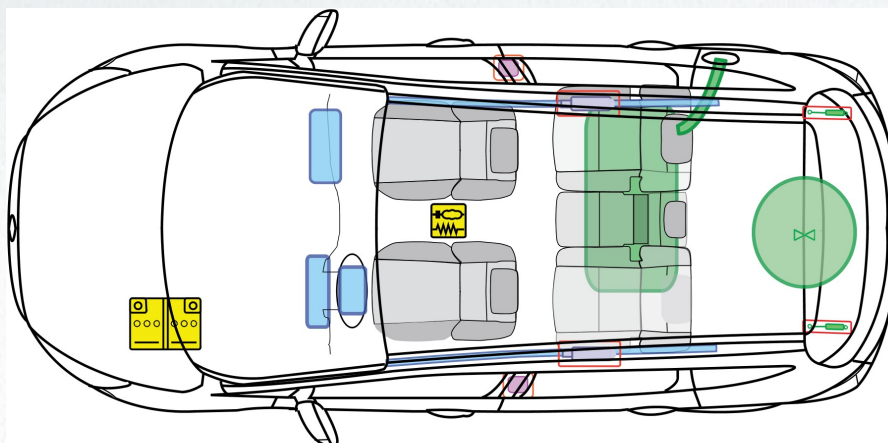





03/2015 – >

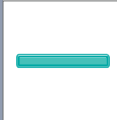

E205006

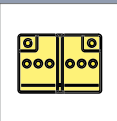
Legende

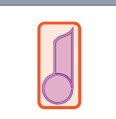
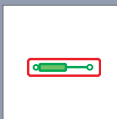
C

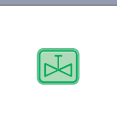
	Airbag		Karosseriever- stärkung		Steuergerät		Fussgänger- schutzsystem
	Gasgenerator		Überrollschutz- bügel		Batterie		Gastank
	Gurtstraffer		Gasdruck- dämpfer		Kraftstofftank		Sicherheits- ventil

(Stand : 05/2015)

FORD C-MAX E=NERGI - HEV

10/2014 – >

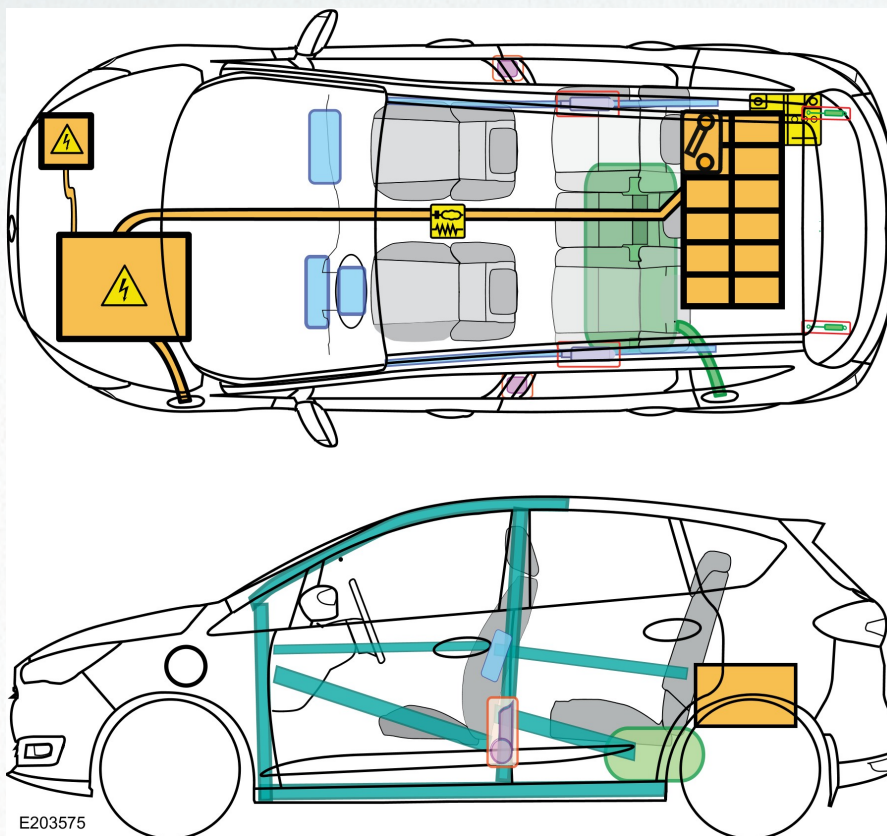

E203575

Legende

C

	Airbag		Karosserieverstärkung		Steuergerät		Hochvoltbatterie		Fussgängerschutzsystem
	Gasgenerator		Überrollschutzbügel		Batterie		Hochvoltleitung/komponenten		
	Gurtstraffer		Gasdruckdämpfer		Kraftstofftank		Hochvolttrennstelle		

(Stand : 12/2015)

HOCHVOLTSYSTEM-Deaktivierung

Vorwort

ES IST IMMER DAVON AUSZUGEHEN; DASS DAS HOCHVOLTSYSTEM DES FAHRZEUGS IN BETRIEB IST!

VOR ARBEITEN AM FAHRZEUG SICHERSTELLEN, DASS EXTERNE STROMVERSORGUNGEN GETRENNT SIND (z. B. Ladegeräte, Elektrowerkzeuge). Das Missachten dieser Anweisung kann zu schweren Verletzungen oder zum Tod führen.

ELEKTROFAHRZEUG-IDENTIFIZIERUNGSNUMMER

Identifizierung anhand der Fahrzeug-Identifizierungsnummer (VIN)

Die 5., 6. und 7. Stellen der Fahrgestellnummer (VIN) identifizieren das Fahrzeug als C-MAX E=NERGI.

VIN-Stellen 1, 2, 3, 4, 5, 6 und 7	FAHRZ WIRD
WFOD	C-MAX E=NERGI
BEISPIEL-VIN	
WF0DUOFL123456	

Identifizierung anhand von Fahrzeugmerkmalen



E202984

1. Schild E=NERGI an beiden Türen vorn und an der Heckklappe
2. HOCHVOLT-Ladeanschluss (im Kotflügel links integriert)

Identifizierung anhand von Merkmalen des Motorraums

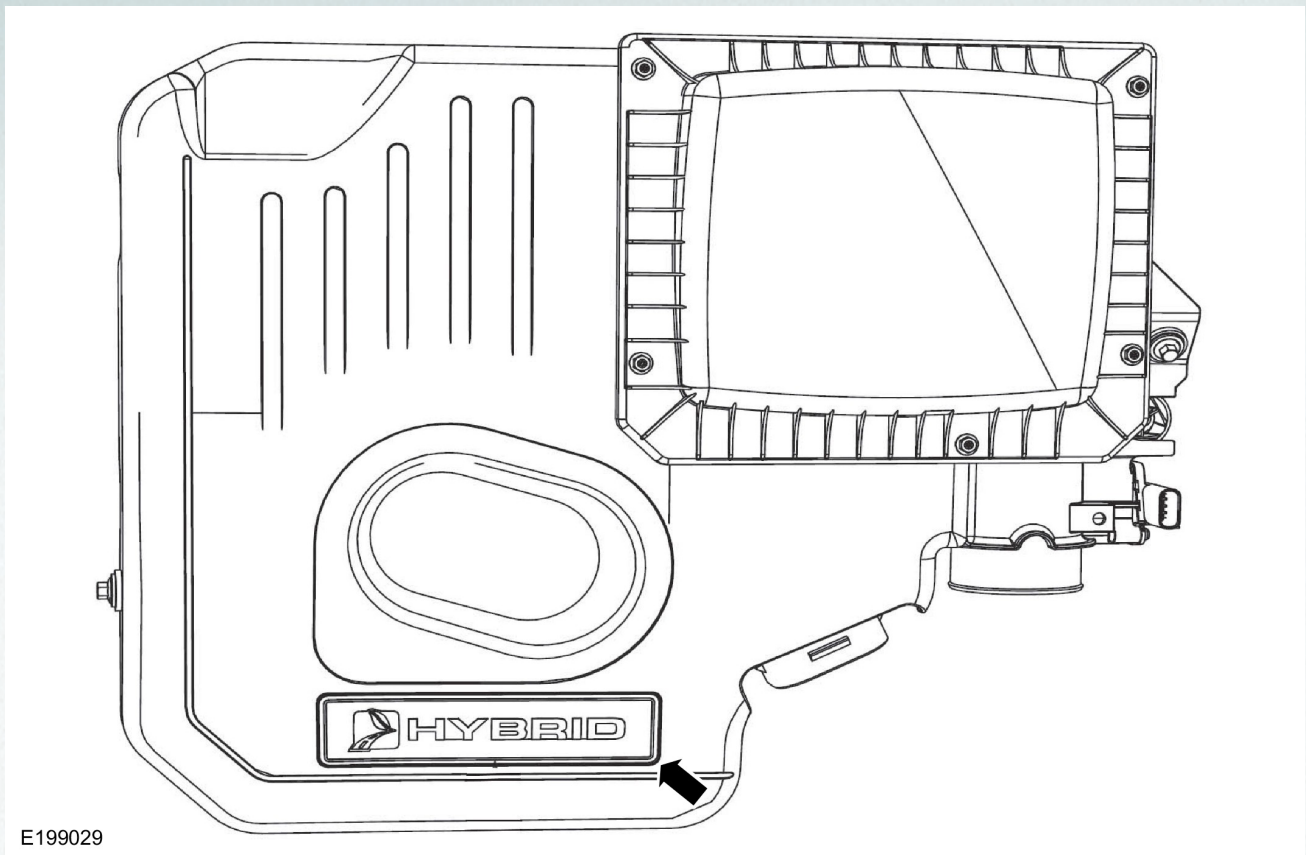

1. Das Fahrzeug C-MAX E=NERGI hat eine unverwechselbare Motorabdeckung mit erhabenem "HYBRID"-Symbol.

FUNKTIONEN ZUM TRENNEN DER HOCHVOLTVERSORUNG

WARNUNGEN:

- ⚠** Durch Abziehen des Hochvolt-Service Steckers wird die Hochspannung vom Fahrzeug getrennt. Die Batteriepackung steht weiterhin unter Spannung und bleibt gefährlich. Das Gehäuse der Hochvoltbatterie nicht schneiden. Die Batterien oder das Gehäuse in keiner Form durchdringen. Nach Möglichkeit für Isolierung sorgen und die Berührung mit Hochvoltbauteilen des Fahrzeugs meiden.
- ⚠** Bei Elektrofahrzeugen, die durch einen Unfall beschädigt wurden, besteht Gefahr durch Hochspannungsstromschlag, weil unter Umständen die Hochvolt-Sicherheitssysteme defekt sind. Vorsicht anwenden und geeignete persönliche Schutzausrüstung tragen. Alle metallhaltigen Schmuckgegenstände wie beispielsweise Uhren und Ringe abnehmen. Das Missachten dieser Anweisung kann zu schweren Verletzungen oder zum Tod führen.

Zündung ist in Position AUS — Wenn die Zündung in Position AUS ist (und das Fahrzeug nicht geladen wird), ist das Hochvoltssystem deaktiviert.

Hochvolt-Service stecker — Bei abgezogenem Hochvolt-Service stecker ist das Hochvoltssystem deaktiviert.

Deaktivierung

Methode 1

Falls kein Zugang zur Batterie möglich ist, mit Methode 2 fortfahren.

1. Das Hochvoltsystem auf Strom prüfen.



E202983

2. Wenn das Hochvoltsystem aktiv ist, den MOTORSTARTKNOPF einmal drücken.



E202982

3. Abdeckung ausbauen, um Zugang zur 12-V-Batterie zu erhalten.

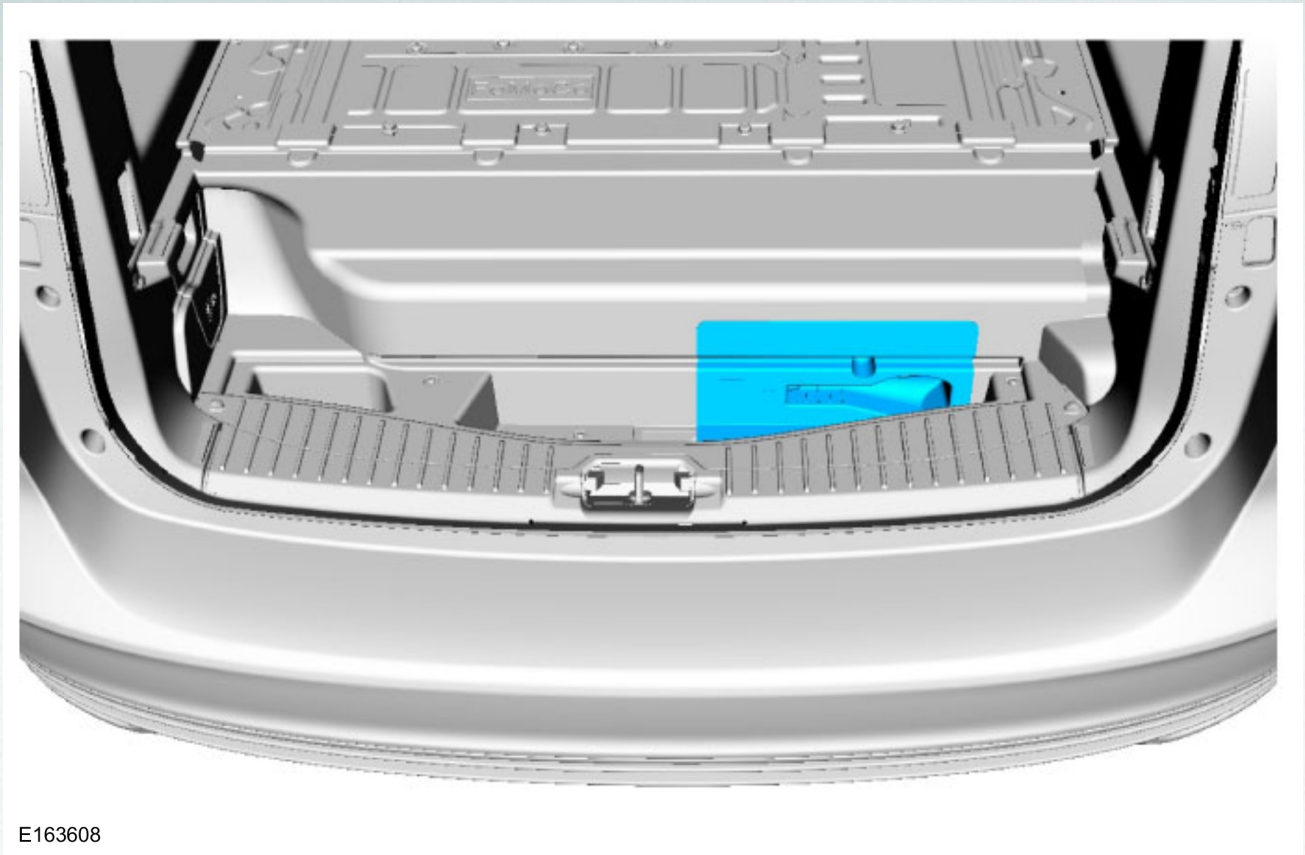

E163608

4. Das Kabel der 12-V-Batterie abnehmen.

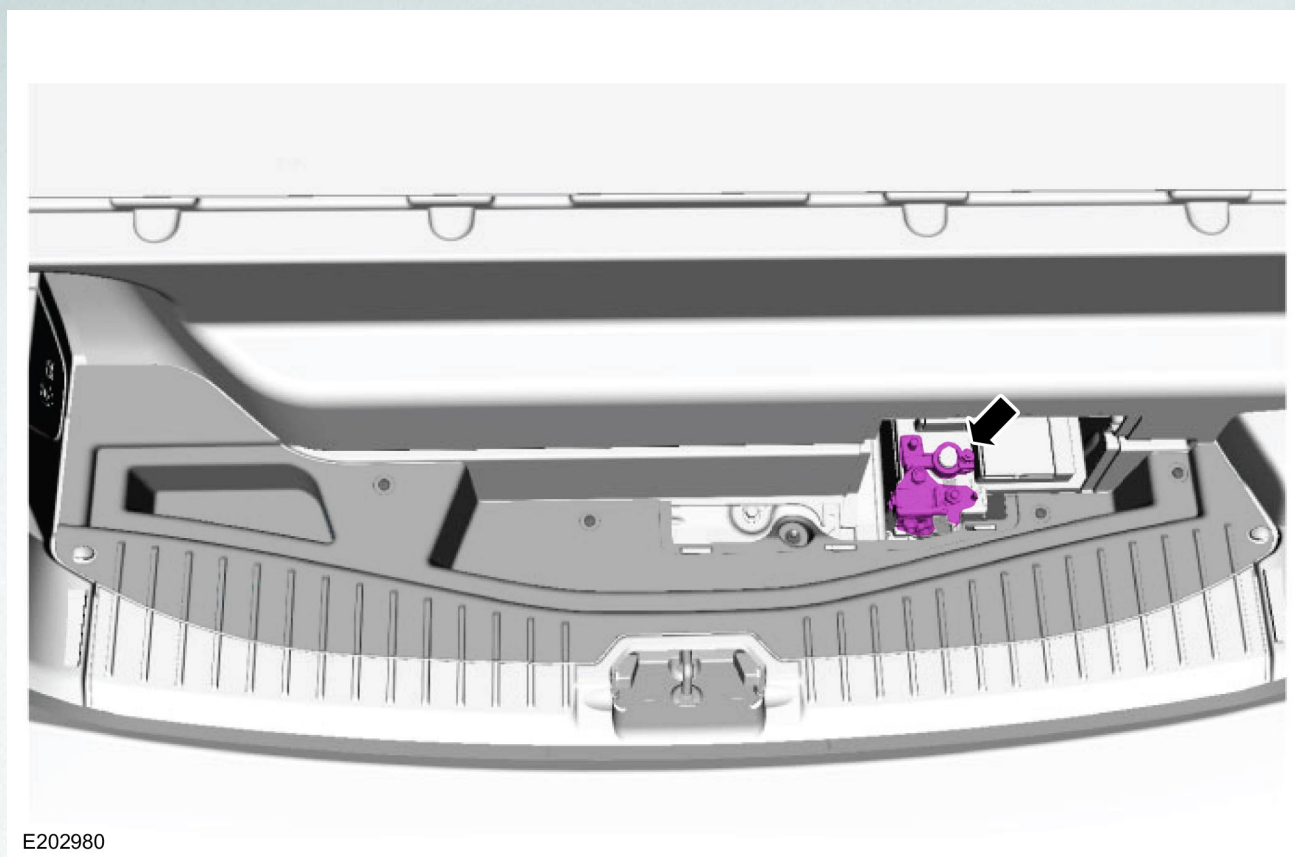

E202980

Methode 2

BEACHTEN: Um Zugang zum Hochvolt-Servicestecker zu erhalten, muss die hintere 40 % Rücksitzlehne heruntergeklappt werden.

1. Den Sitzlehnen-Entriegelungshebel oben auf der Sitzlehne ermitteln.

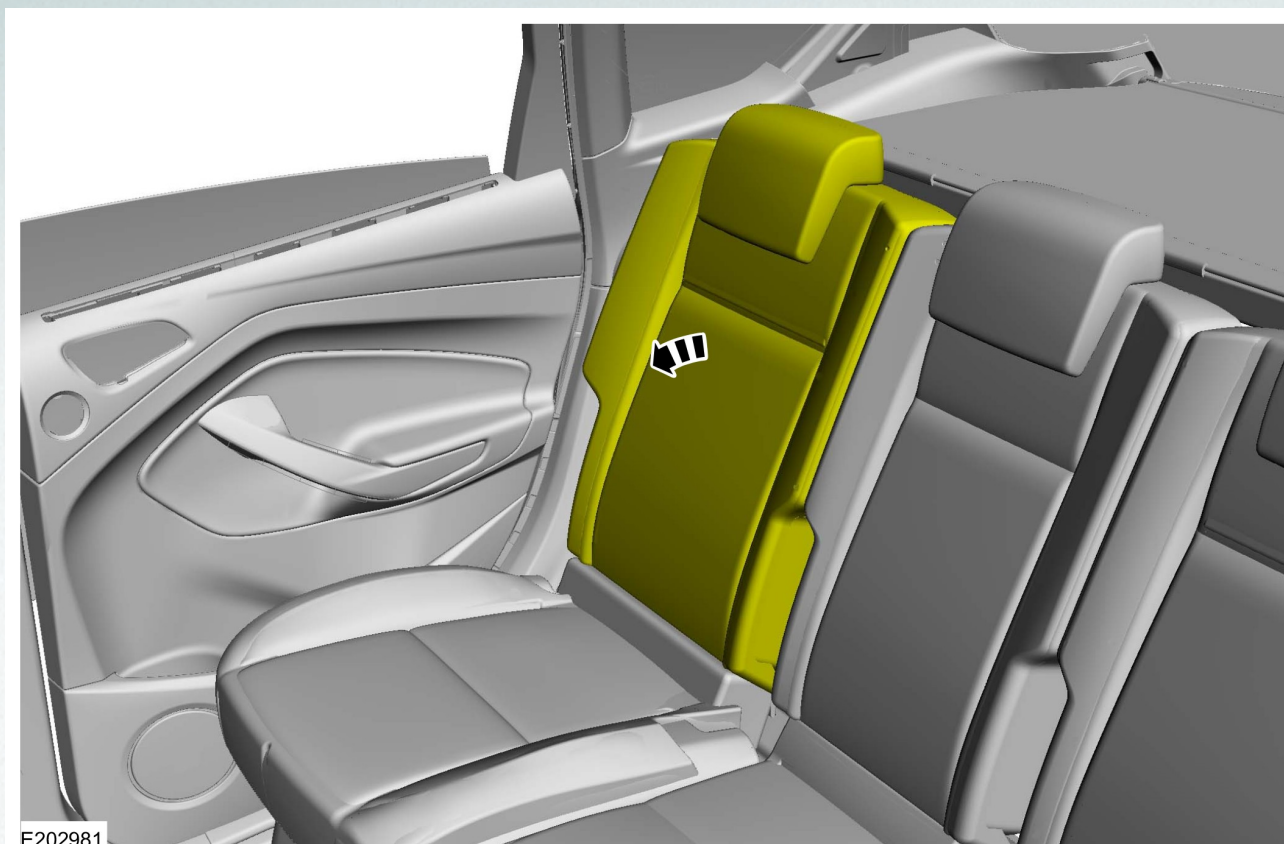

2. Abdeckung abnehmen, um Zugang zum oberen Batterieservicestecker zu erhalten.

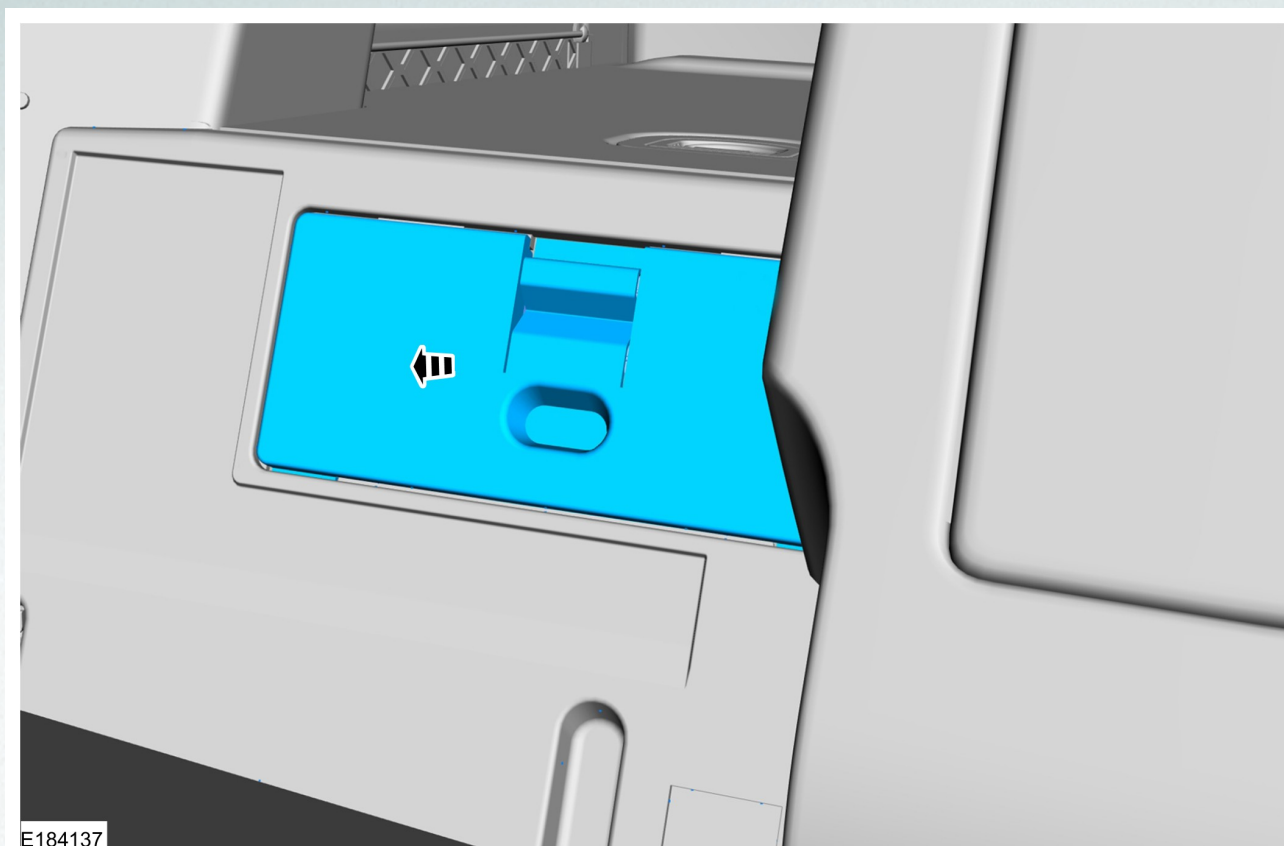

E184137

3. Den HOCHVOLT-SERVICESTECKER abziehen.

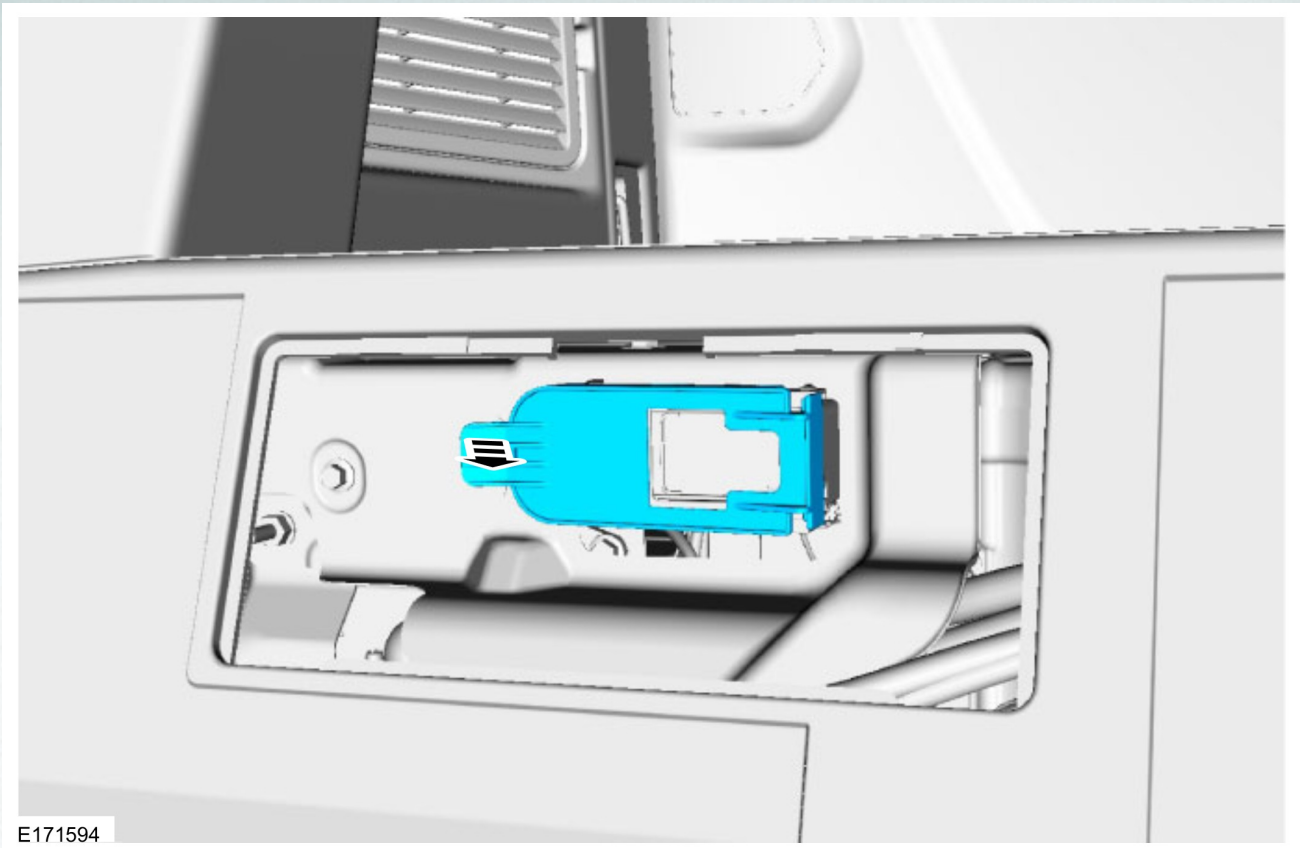

E171594

4. Den HOCHVOLT-SERVICESTECKER abziehen.

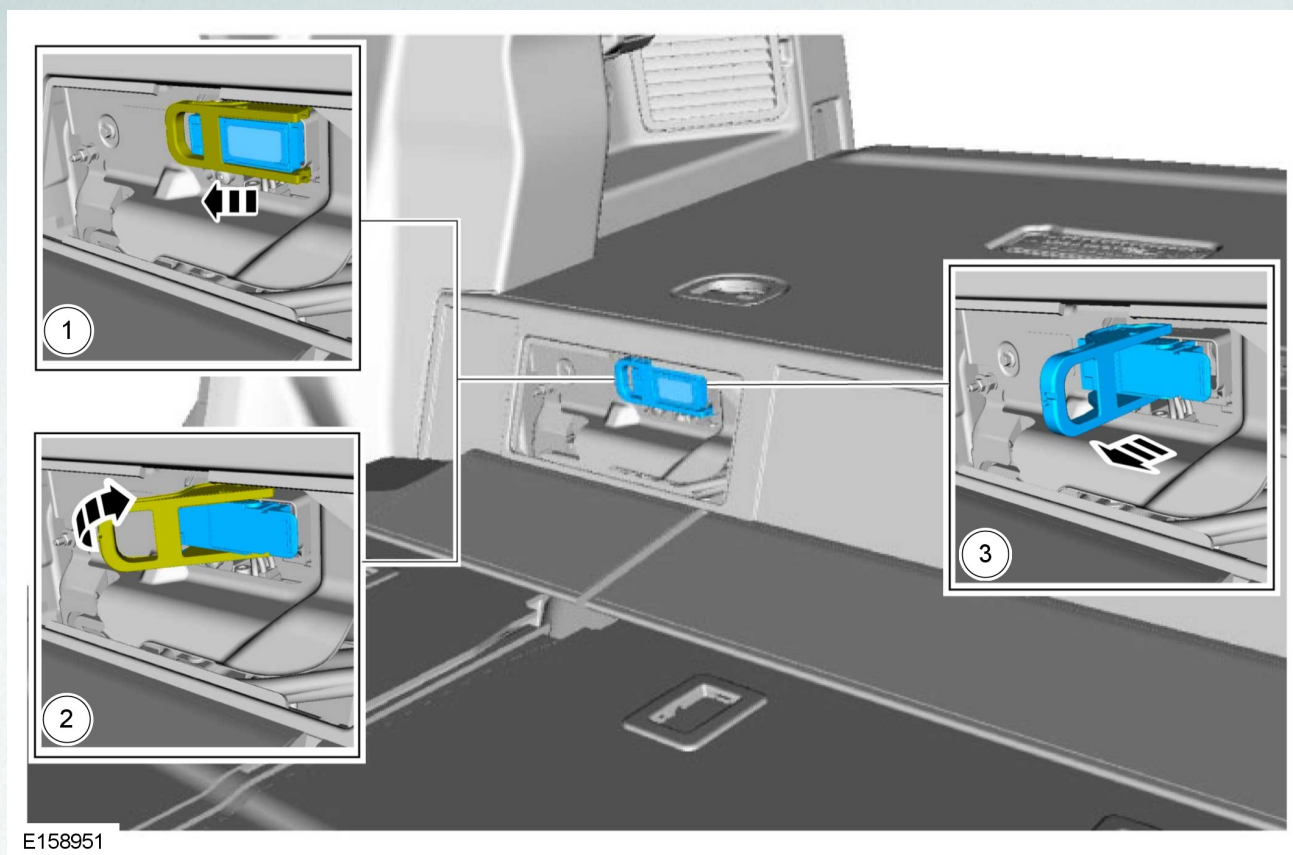

(Stand : 12/2015)

FORD Eco Sport

09/2013 – >



E178558

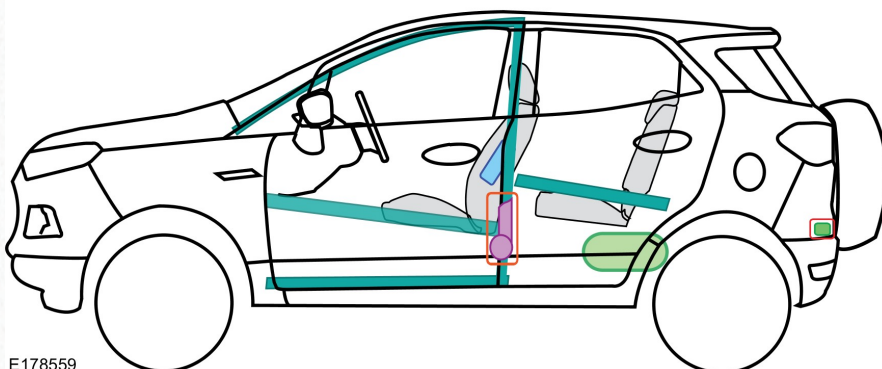
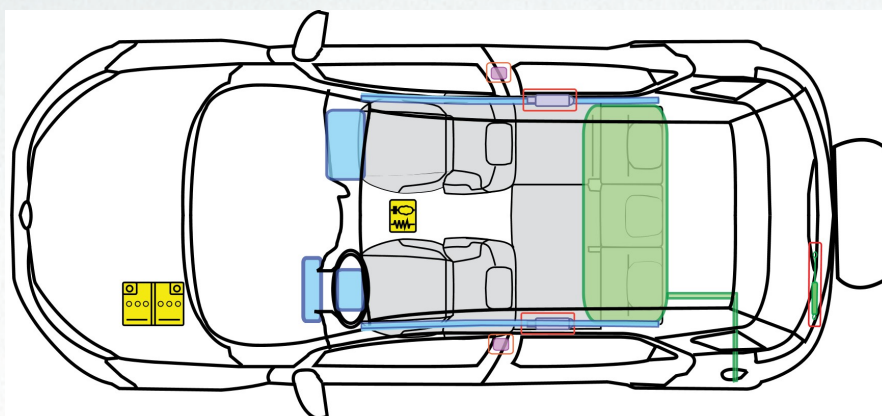

E178559

Legende

E

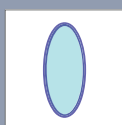

Airbag

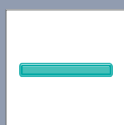

Karosseriever-
stärkung



Steuergerät



Fussgänger-
schutzsystem

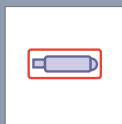

Gasgenerator

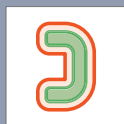

Überrollschutz-
bügel

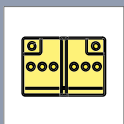

Batterie

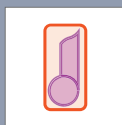

Gurtstraffer

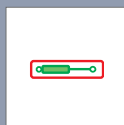

Gasdruck-
dämpfer



Kraftstofftank

(Stand : 11/2017)

FORD Edge

06/2018 – >





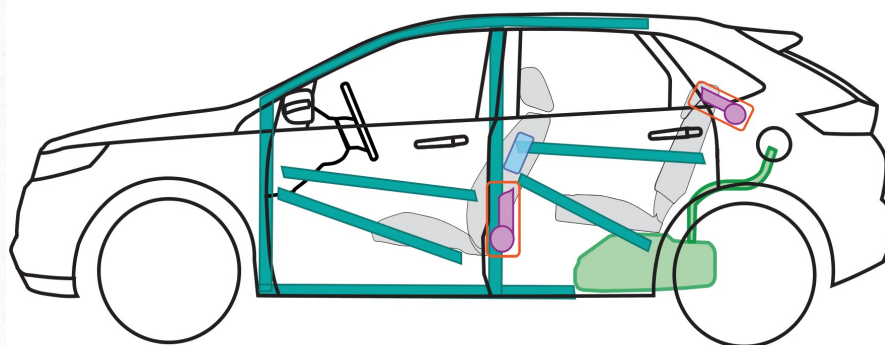
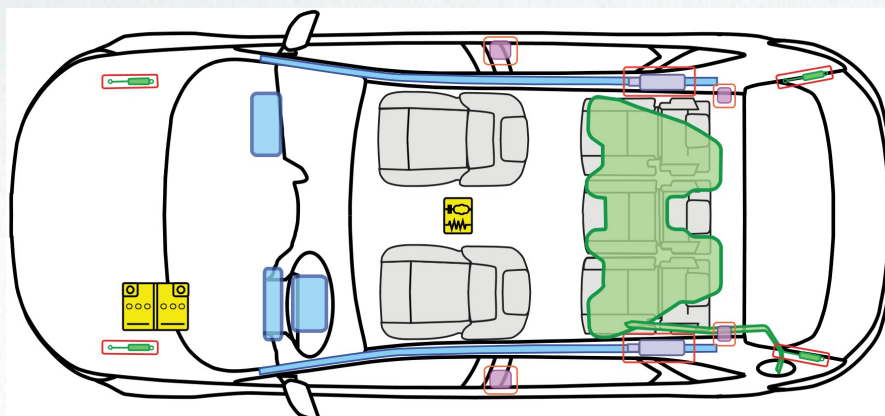



E303279

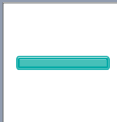
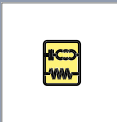

E303280

Legende

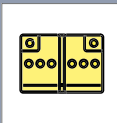
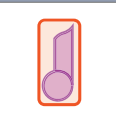
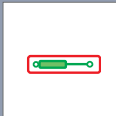
E

	Airbag		Karosseriever- stärkung		Steuergerät		Fussgänger- schutzsystem
	Gasgenerator		Überrollschutz- bügel		Batterie		
	Gurtstraffer		Gasdruck- dämpfer		Kraftstofftank		

(Stand : 05/2019)

FORD **Edge**





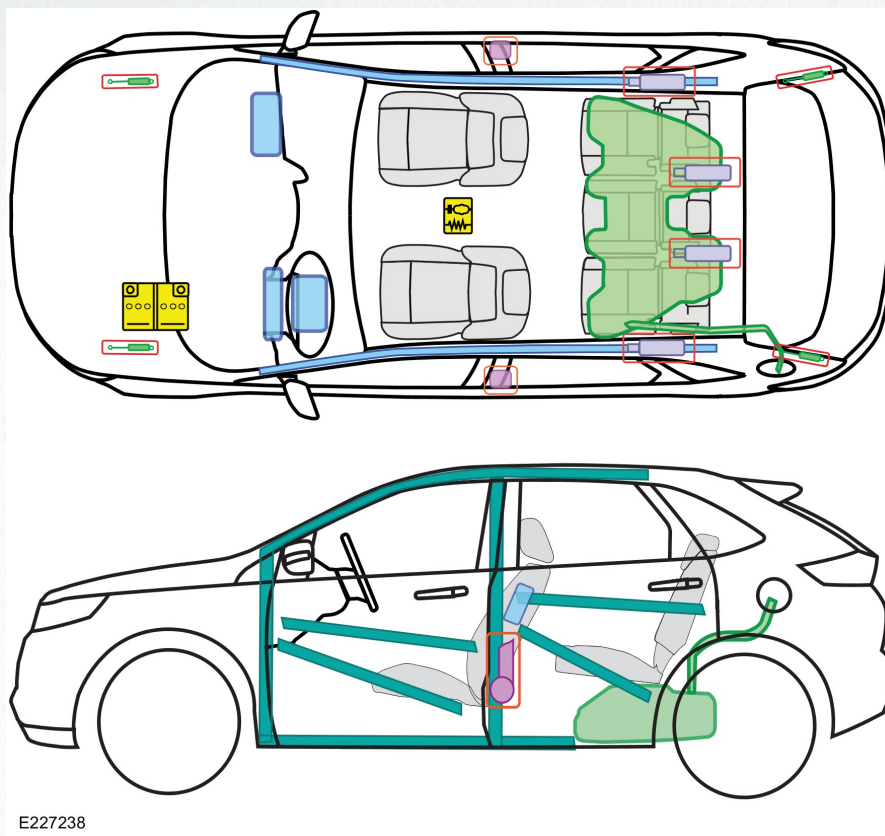

5-Türer SUV

10/2015 – >

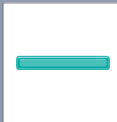

Legende

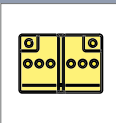
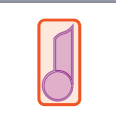
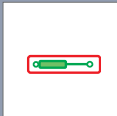
E

	Airbag		Karosseriever- stärkung		Steuergerät		Fussgänger- schutzsystem
	Gasgenerator		Überrollschutz- bügel		Batterie		
	Gurtstraffer		Gasdruck- dämpfer		Kraftstofftank		

(Stand : 01/2016)

FORD Fiesta

01/1996 – 02/2000



E137299

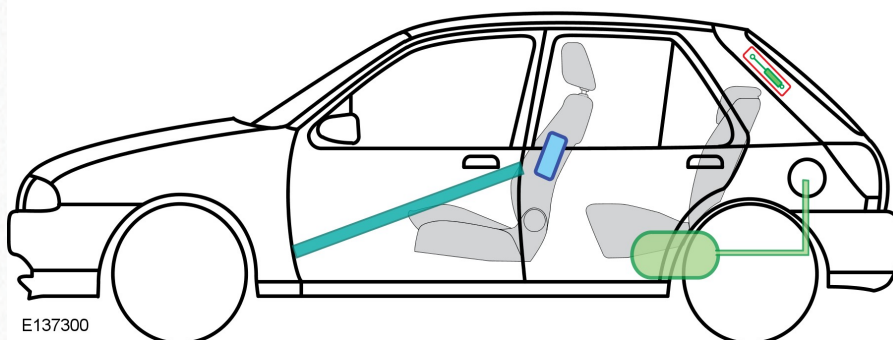
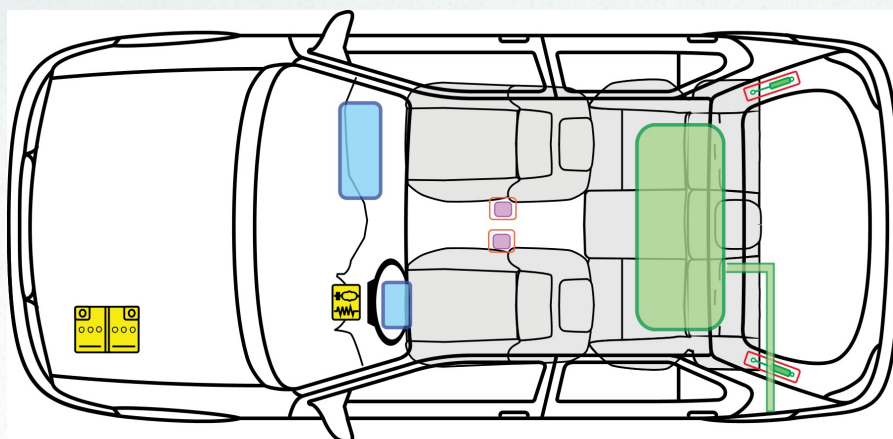

E137300

Legende

F

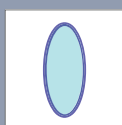

Airbag

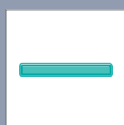

Karosseriever-
stärkung



Steuergerät



Fussgänger-
schutzsystem



Gasgenerator



Überrollschutz-
bügel

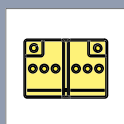

Batterie

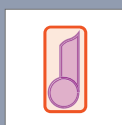

Gurtstraffer

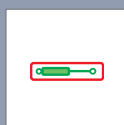

Gasdruck-
dämpfer



Kraftstofftank

(Stand : 01/2011)



FORD **Fiesta**

02/2000 – 02/2002



E170168

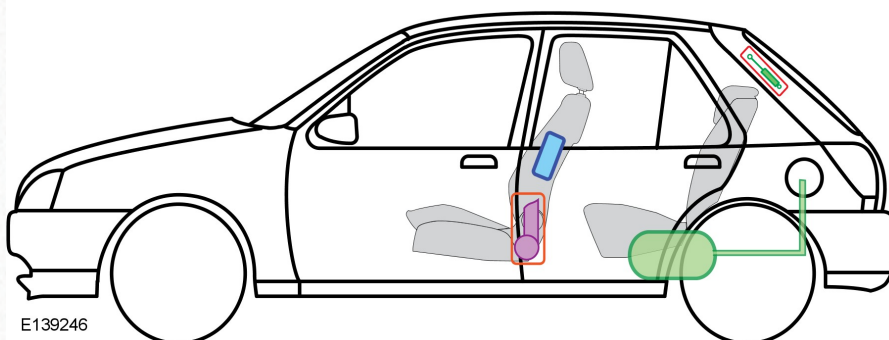
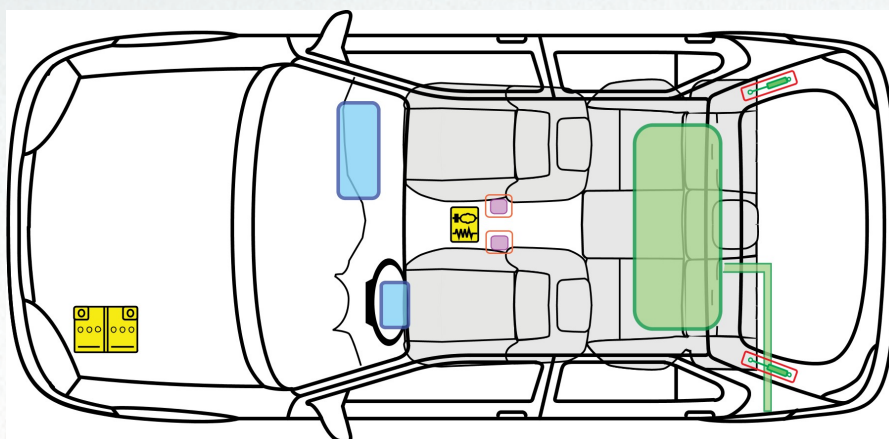

E139246

Legende

F

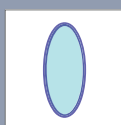

Airbag

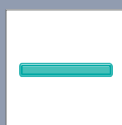

Karosseriever-
stärkung



Steuergerät



Fussgänger-
schutzsystem



Gasgenerator



Überrollschutz-
bügel

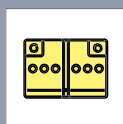

Batterie

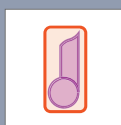

Gurtstraffer

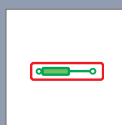

Gasdruck-
dämpfer



Kraftstofftank

(Stand : 05/2013)

FORD **Fiesta**

3-Türer

06/2008 – 04/2017

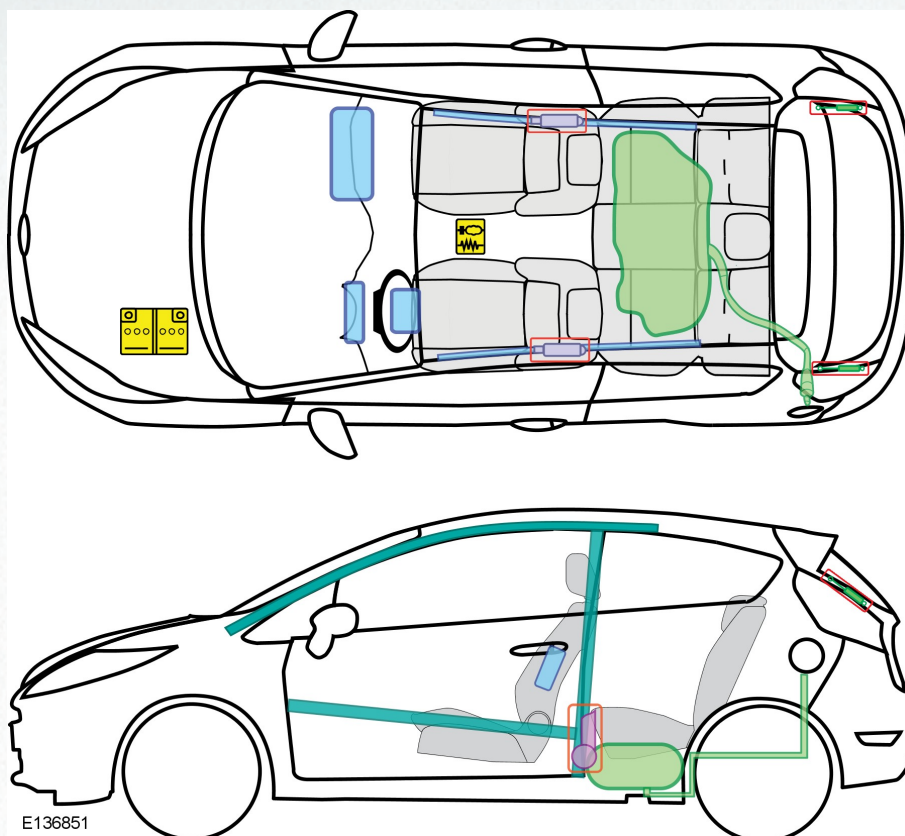

Legende

F

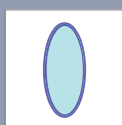

Airbag

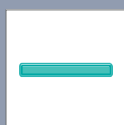

Karosseriever-
stärkung



Steuergerät



Fussgänger-
schutzsystem



Gasgenerator



Überrollschutz-
bügel

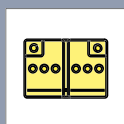

Batterie

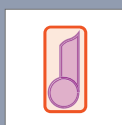

Gurtstraffer

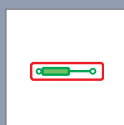

Gasdruck-
dämpfer



Kraftstofftank

(Stand : 03/2011)

FORD **Fiesta**

3-Türer

11/2001 – 09/2008

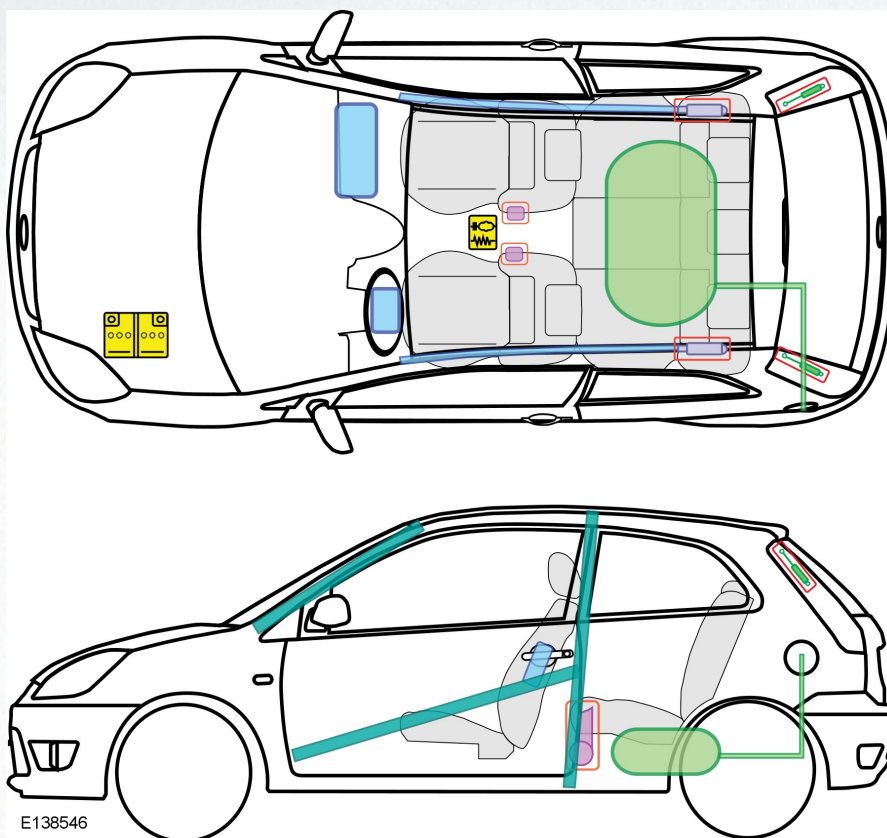

E138546

Legende

F

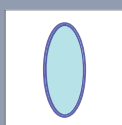

Airbag

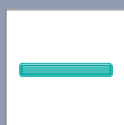

Karosseriever-
stärkung



Steuergerät



Fussgänger-
schutzsystem



Gasgenerator



Überrollschutz-
bügel

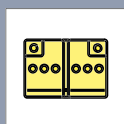

Batterie

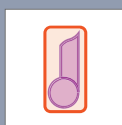

Gurtstraffer

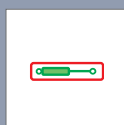

Gasdruck-
dämpfer



Kraftstofftank

(Stand : 03/2011)

FORD **Fiesta**

3-Türer

04/2017 – >



E255449

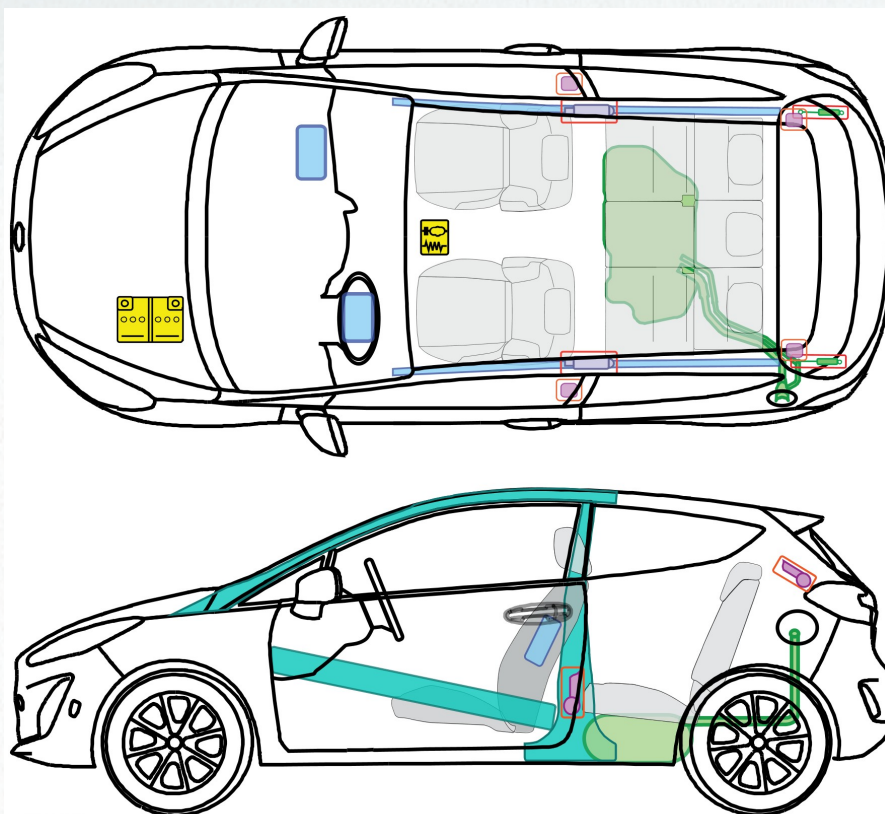

E255450

Legende

F

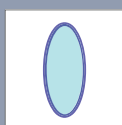

Airbag

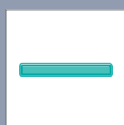

Karosseriever-
stärkung



Steuergerät



Fussgänger-
schutzsystem



Gasgenerator



Überrollschut-
bügel

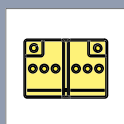

Batterie

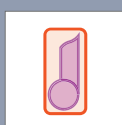

Gurtstraffer

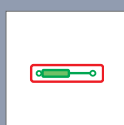

Gasdruck-
dämpfer



Kraftstofftank

(Stand : 05/2017)

FORD Fiesta - LPG

3-Türer

06/2008 – 04/2017

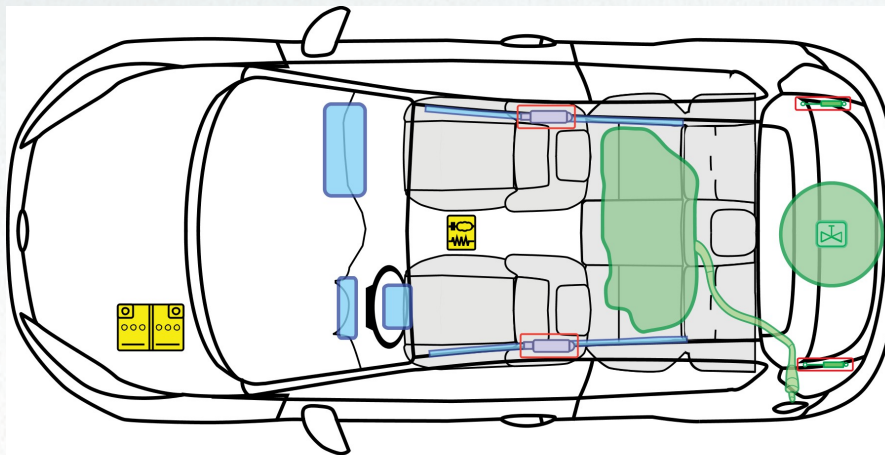



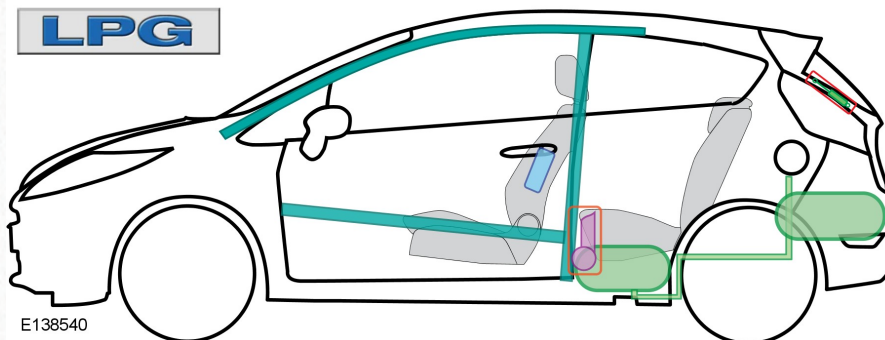

LPG



E138540

Legende

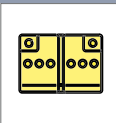
F

	Airbag		Karosseriever- stärkung		Steuergerät		Fussgänger- schutzsystem
	Gasgenerator		Überrollschutz- bügel		Batterie		Gastank
	Gurtstraffer		Gasdruck- dämpfer		Kraftstofftank		Sicherheits- ventil

(Stand : 03/2011)

FORD Fiesta

5-Türer

11/2001 – 09/2008

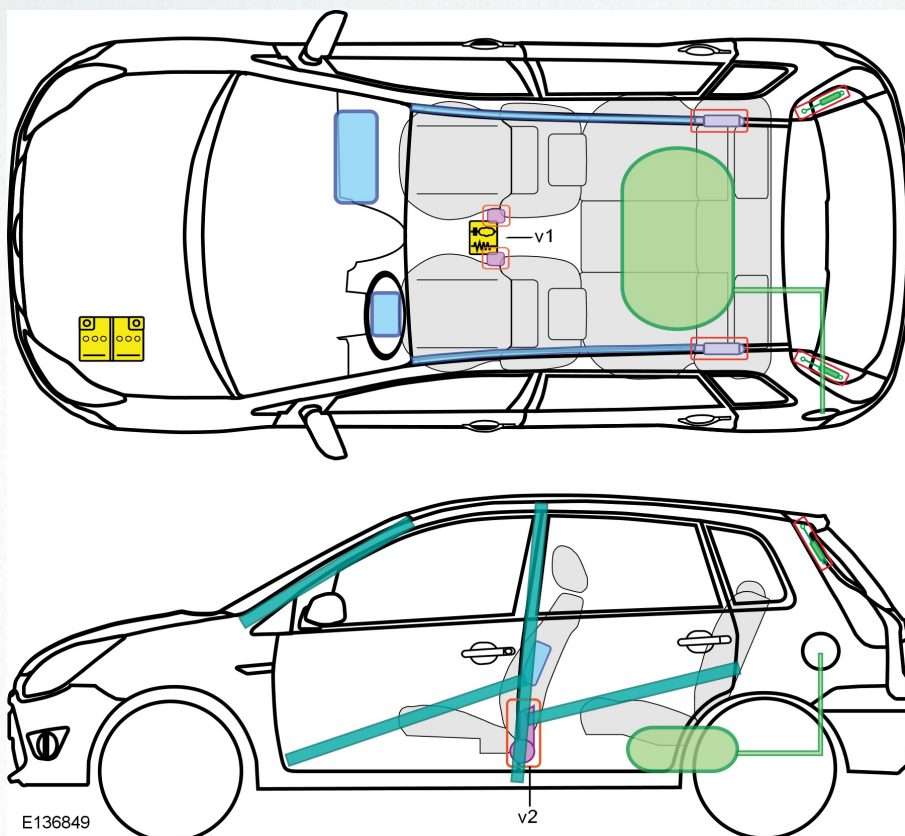

E136849

Legende

F

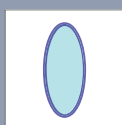

Airbag

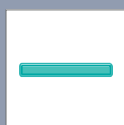

Karosseriever-
stärkung

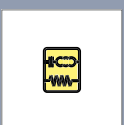

Steuergerät



Fussgänger-
schutzsystem



Gasgenerator



Überrollschutz-
bügel

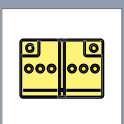

Batterie

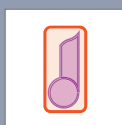

Gurtstraffer

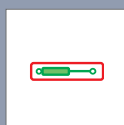

Gasdruck-
dämpfer



Kraftstofftank

(Stand : 09/2011)

FORD **Fiesta**

5-Türer

06/2008 – 04/2017

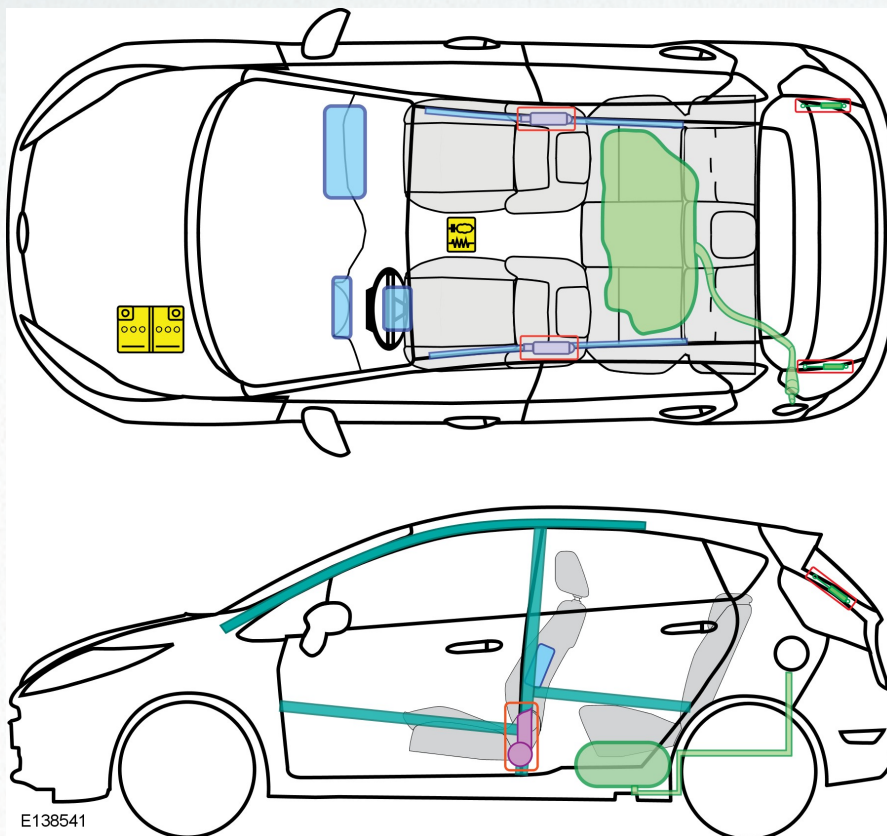

E138541

Legende

F

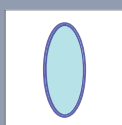

Airbag

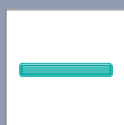

Karosseriever-
stärkung



Steuergerät



Fussgänger-
schutzsystem

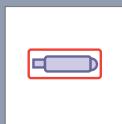

Gasgenerator



Überrollschutz-
bügel

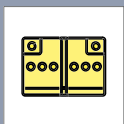

Batterie

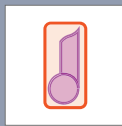

Gurtstraffer

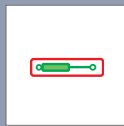

Gasdruck-
dämpfer



Kraftstofftank

(Stand : 07/2013)

FORD **Fiesta**

5-Türer

04/2017 – >

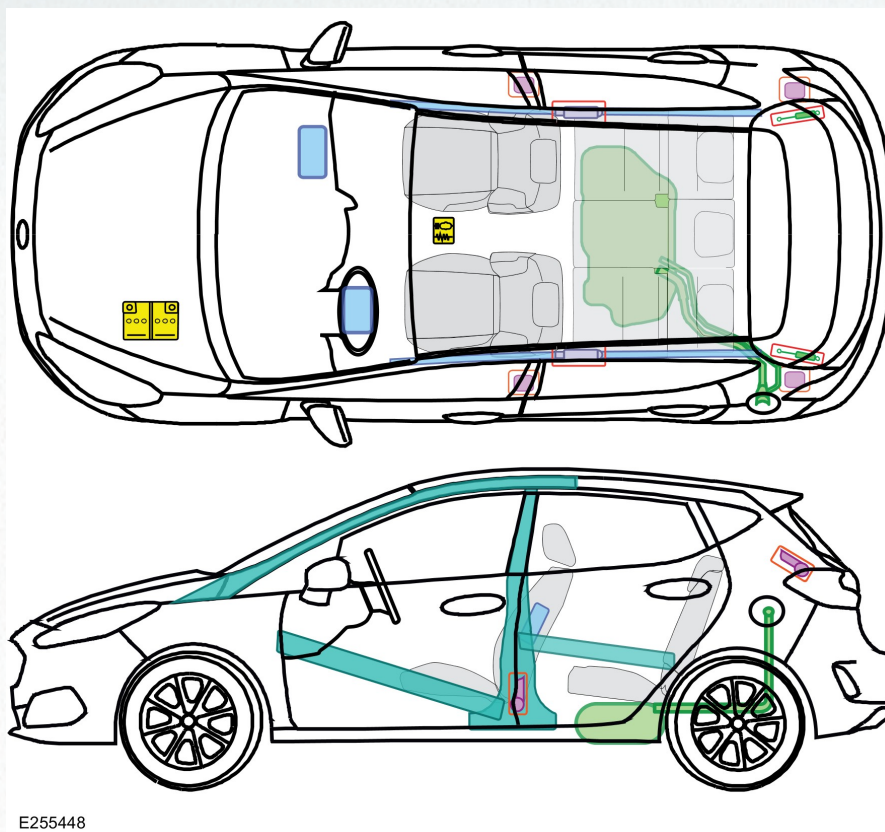

E255448

Legende

F

	Airbag		Karosseriever- stärkung		Steuergerät		Fussgänger- schutzsystem
	Gasgenerator		Überrollschutz- bügel		Batterie		
	Gurtstraffer		Gasdruck- dämpfer		Kraftstofftank		

(Stand : 05/2017)

FORD Fiesta - LPG

5-Türer

06/2008 – 04/2017



E138536

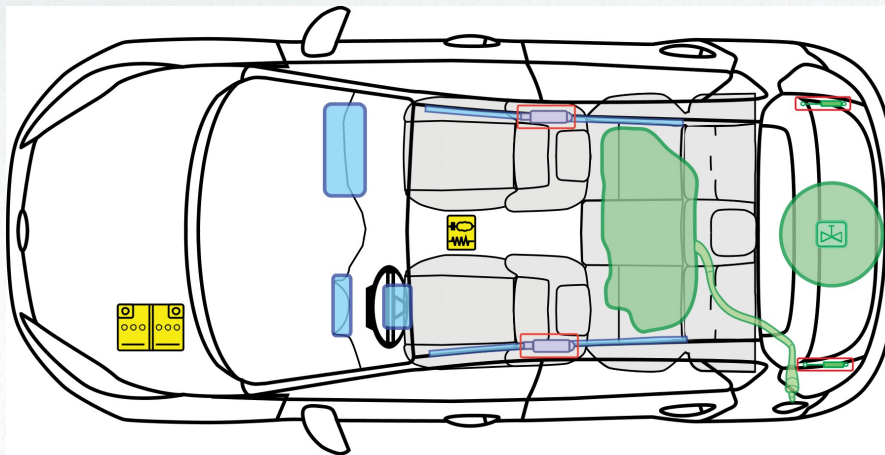

LPG

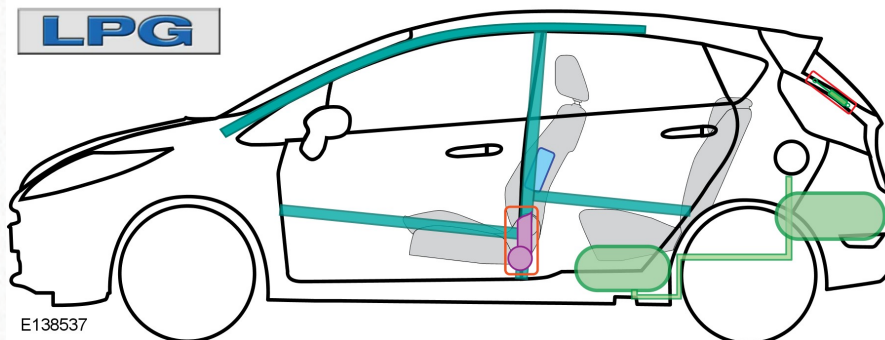

E138537

Legende

F

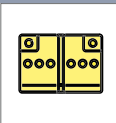
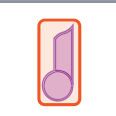
	Airbag		Karosseriever- stärkung		Steuergerät		Fussgänger- schutzsystem
	Gasgenerator		Überrollschutz- bügel		Batterie		Gastank
	Gurtstraffer		Gasdruck- dämpfer		Kraftstofftank		Sicherheits- ventil

(Stand : 03/2011)

FORD Focus

3-Türer

07/2004 – 08/2007



E137212

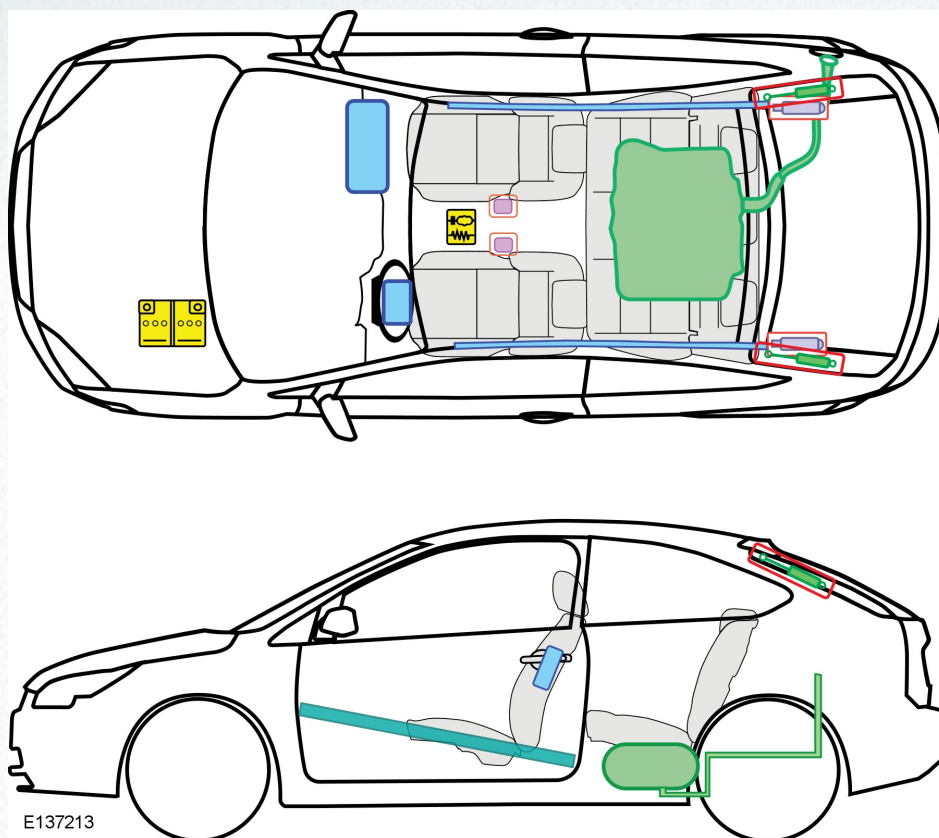

E137213

Legende

F

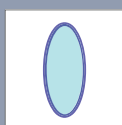

Airbag

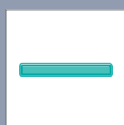

Karosseriever-
stärkung



Steuergerät



Fussgänger-
schutzsystem



Gasgenerator



Überrollschutz-
bügel

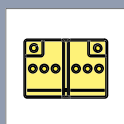

Batterie

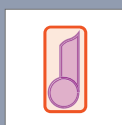

Gurtstraffer

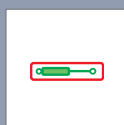

Gasdruck-
dämpfer



Kraftstofftank

(Stand : 03/2011)

FORD Focus

3-Türer

08/2007 – 03/2011

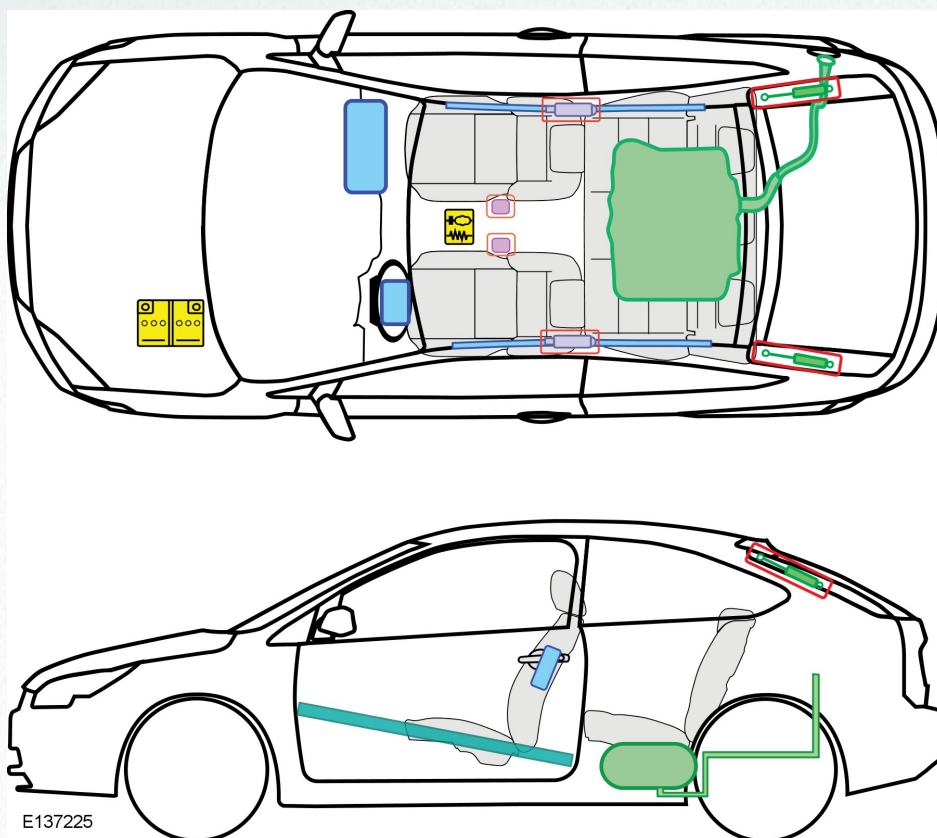

Legende

F

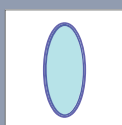

Airbag

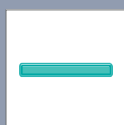

Karosseriever-
stärkung



Steuergerät



Fussgänger-
schutzsystem

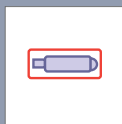

Gasgenerator



Überrollschutz-
bügel

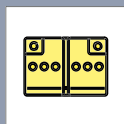

Batterie

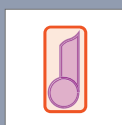

Gurtstraffer

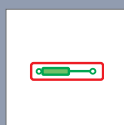

Gasdruck-
dämpfer



Kraftstofftank

(Stand : 03/2011)

FORD Focus

3-Türer

08/1998 – 12/2004

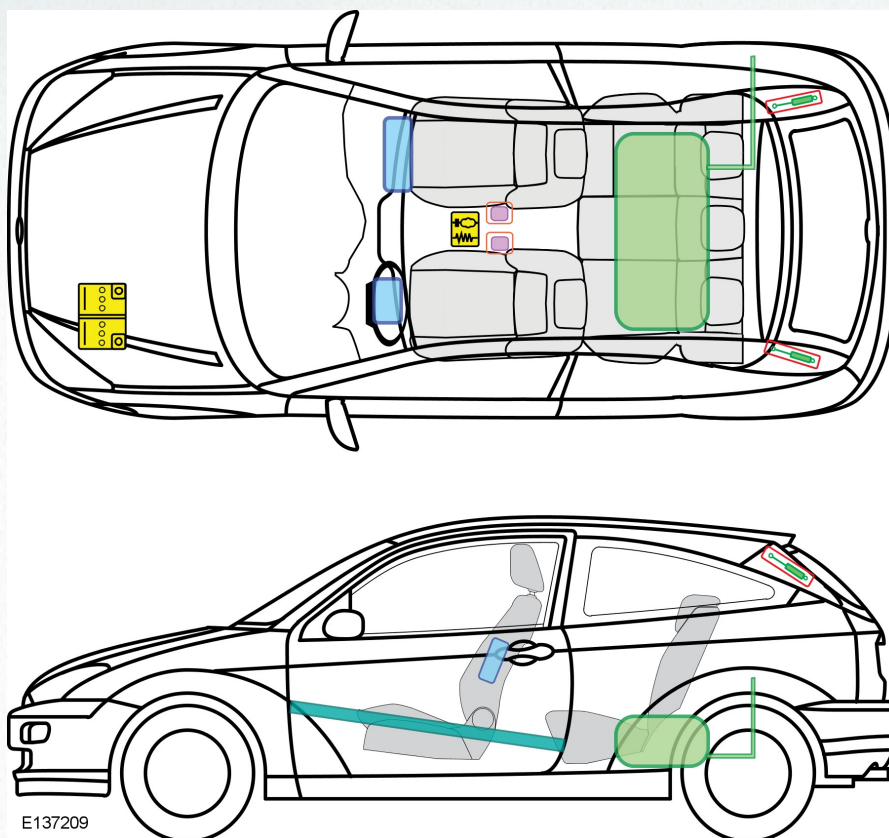

Legende

F

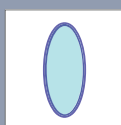

Airbag

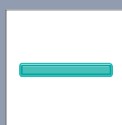

Karosseriever-
stärkung



Steuergerät



Fussgänger-
schutzsystem



Gasgenerator



Überrollschutz-
bügel

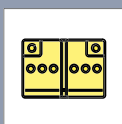

Batterie

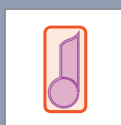

Gurtstraffer

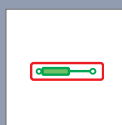

Gasdruck-
dämpfer



Kraftstofftank

(Stand : 03/2011)

FORD Focus - LPG

3-Türer

08/2007 – 03/2011

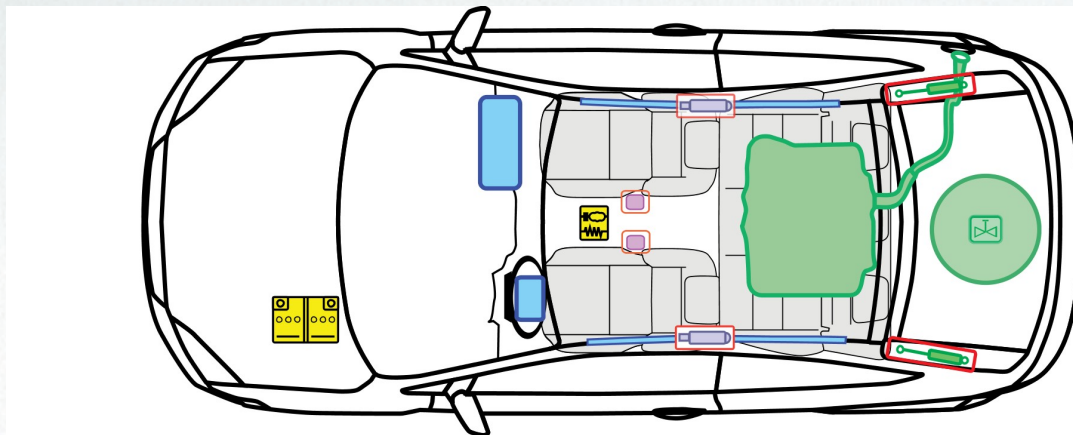



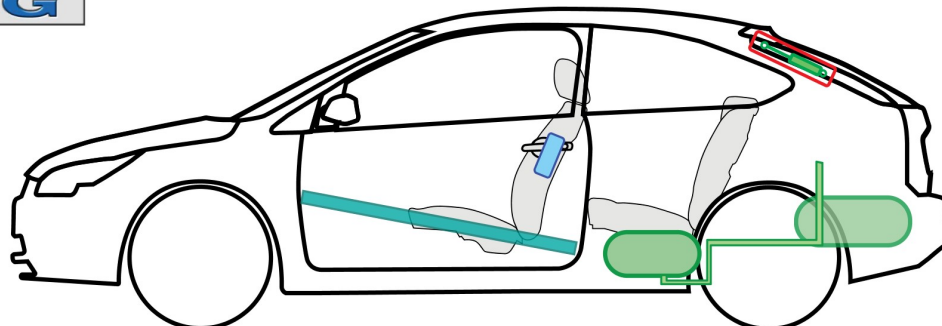

LPG



E137493

Legende

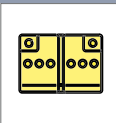
F

	Airbag		Karosseriever- stärkung		Steuergerät		Fussgänger- schutzsystem
	Gasgenerator		Überrollschutz- bügel		Batterie		Gastank
	Gurtstraffer		Gasdruck- dämpfer		Kraftstofftank		Sicherheits- ventil

(Stand : 01/2011)

FORD Focus - LPG

3-Türer

07/2004 – 08/2007

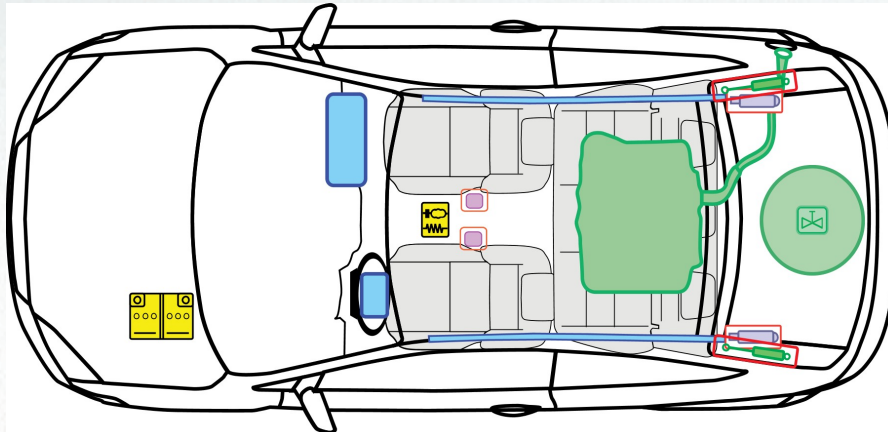

LPG

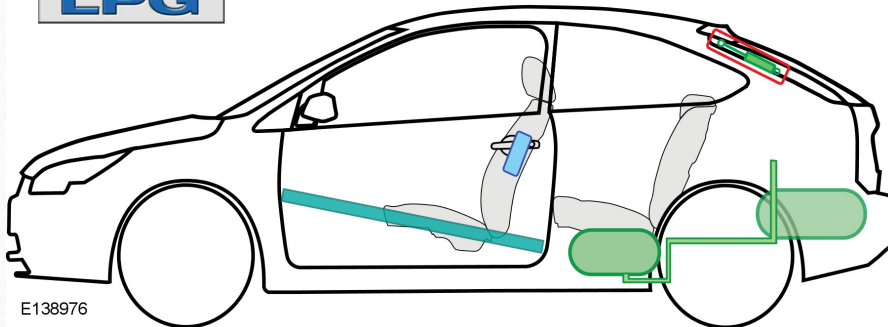

E138976

Legende

F

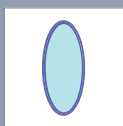

Airbag

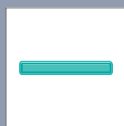

Karosseriever-
stärkung



Steuergerät



Fussgänger-
schutzsystem

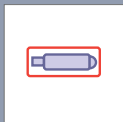

Gasgenerator



Überrollschutz-
bügel

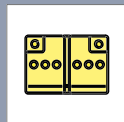

Batterie



Gastank

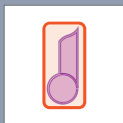

Gurtstraffer

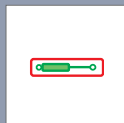

Gasdruck-
dämpfer



Kraftstofftank

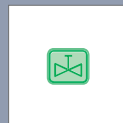

Sicherheits-
ventil

(Stand : 03/2011)

FORD Focus - CNG

3-Türer

07/2004 – 08/2007

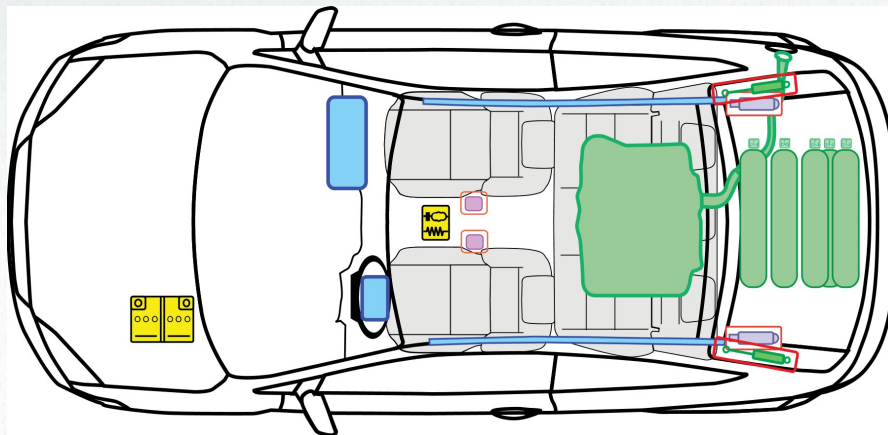



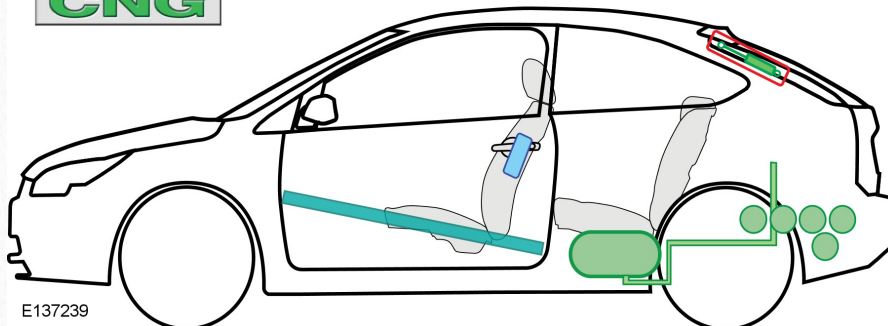

CNG



E137239

Legende

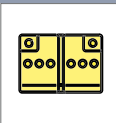
F

	Airbag		Karosseriever- stärkung		Steuergerät		Fussgänger- schutzsystem
	Gasgenerator		Überrollschutz- bügel		Batterie		Gastank
	Gurtstraffer		Gasdruck- dämpfer		Kraftstofftank		Sicherheits- ventil

(Stand : 03/2011)

FORD Focus - CNG

3-Türer

08/2007 – 03/2011



E137224

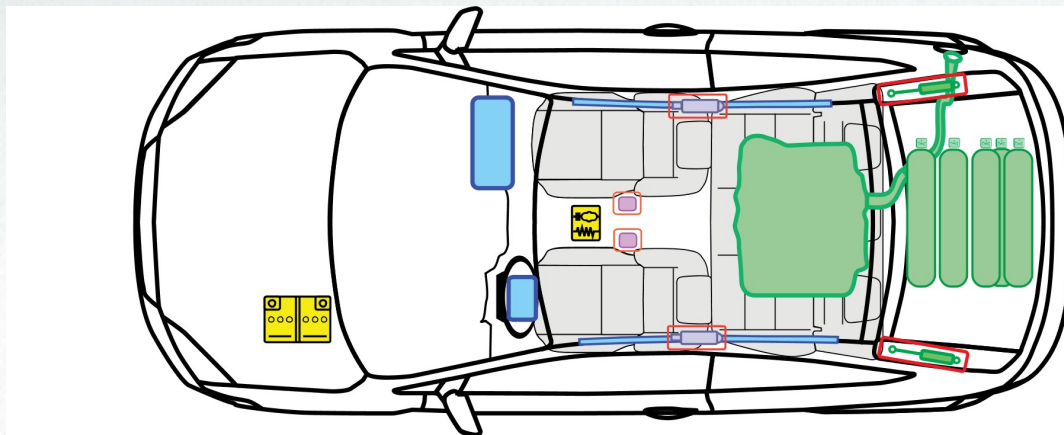

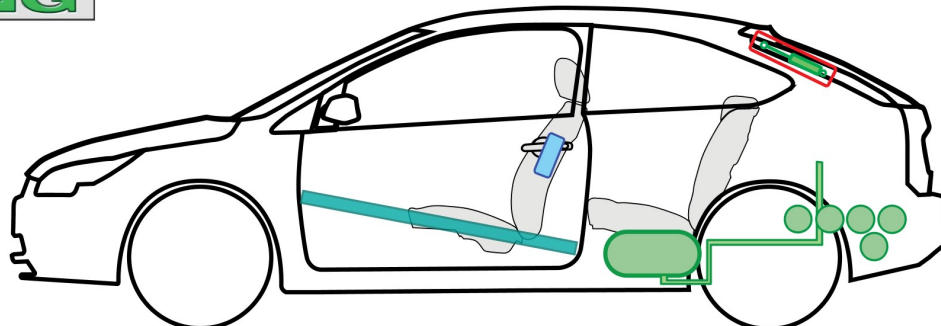

CNG



E137463

Legende

F

	Airbag		Karosseriever- stärkung		Steuergerät		Fussgänger- schutzsystem
	Gasgenerator		Überrollschutz- bügel		Batterie		Gastank
	Gurtstraffer		Gasdruck- dämpfer		Kraftstofftank		Sicherheits- ventil

(Stand : 01/2011)

FORD Focus

4-Türer

07/2004 – 08/2007

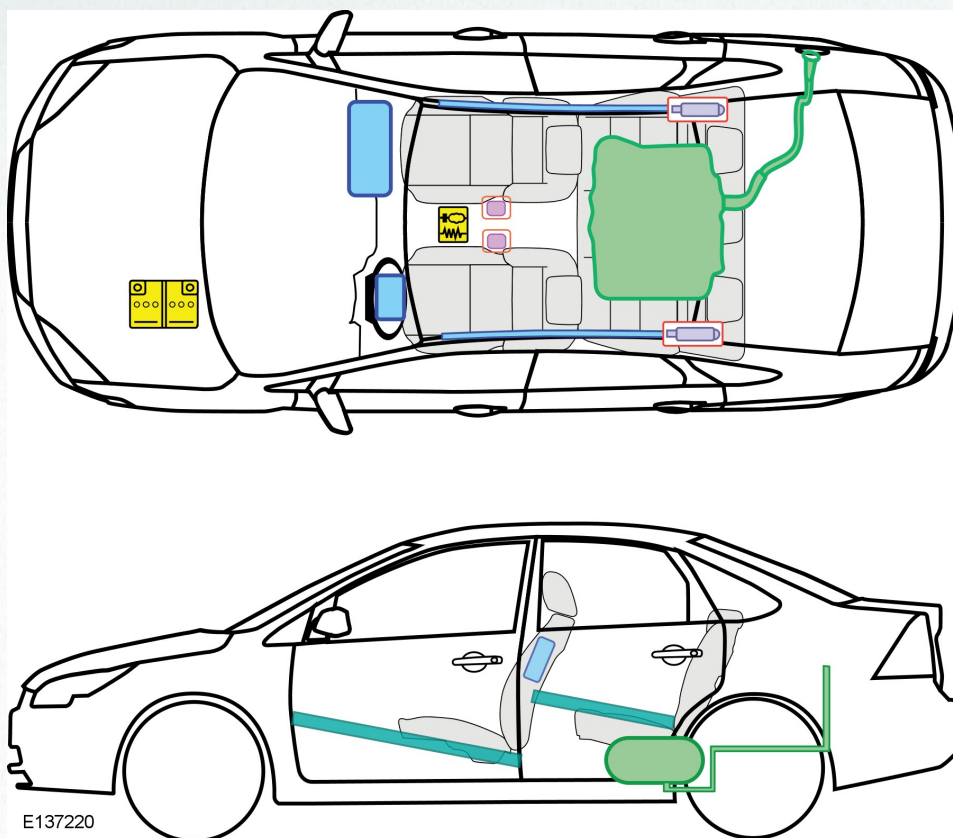

E137220

Legende

F

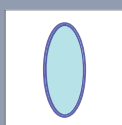

Airbag

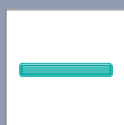

Karosseriever-
stärkung



Steuergerät



Fussgänger-
schutzsystem



Gasgenerator



Überrollschutz-
bügel

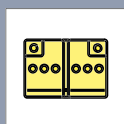

Batterie

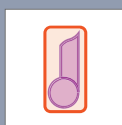

Gurtstraffer

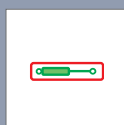

Gasdruck-
dämpfer



Kraftstofftank

(Stand : 03/2011)

FORD Focus

4-Türer

08/1998 – 12/2004

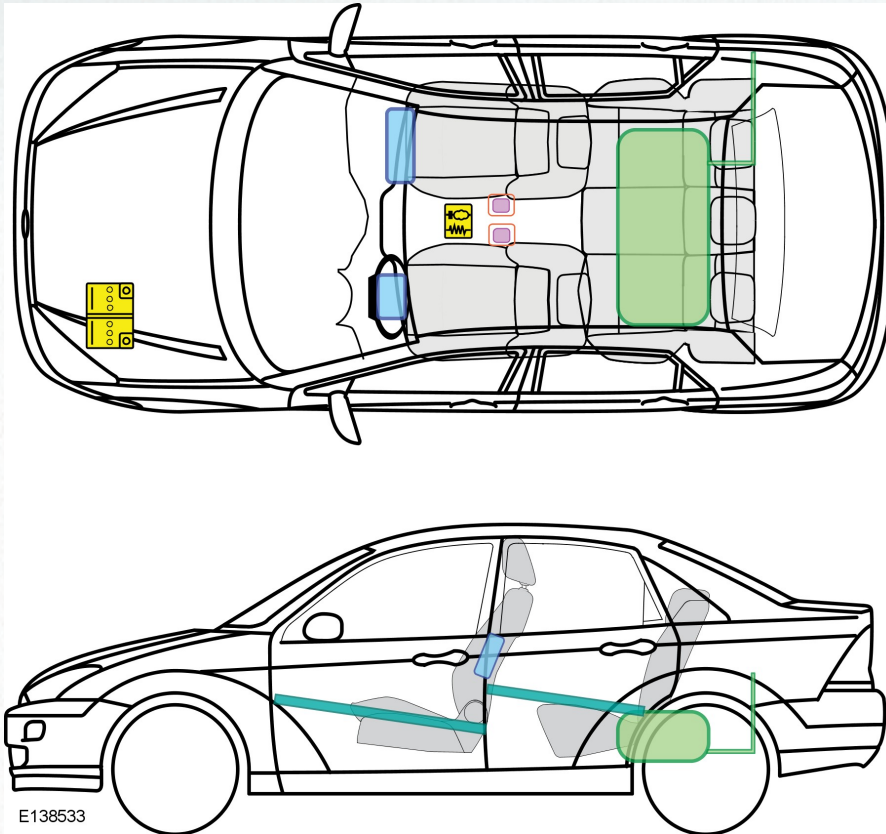

Legende

F

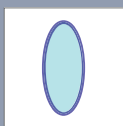

Airbag

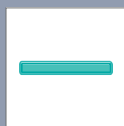

Karosseriever-
stärkung



Steuergerät



Fussgänger-
schutzsystem

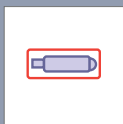

Gasgenerator

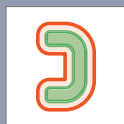

Überrollschutz-
bügel

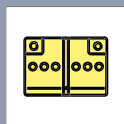

Batterie

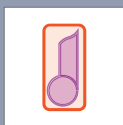

Gurtstraffer

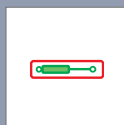

Gasdruck-
dämpfer

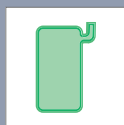

Kraftstofftank

(Stand : 03/2011)

FORD Focus

4-Türer



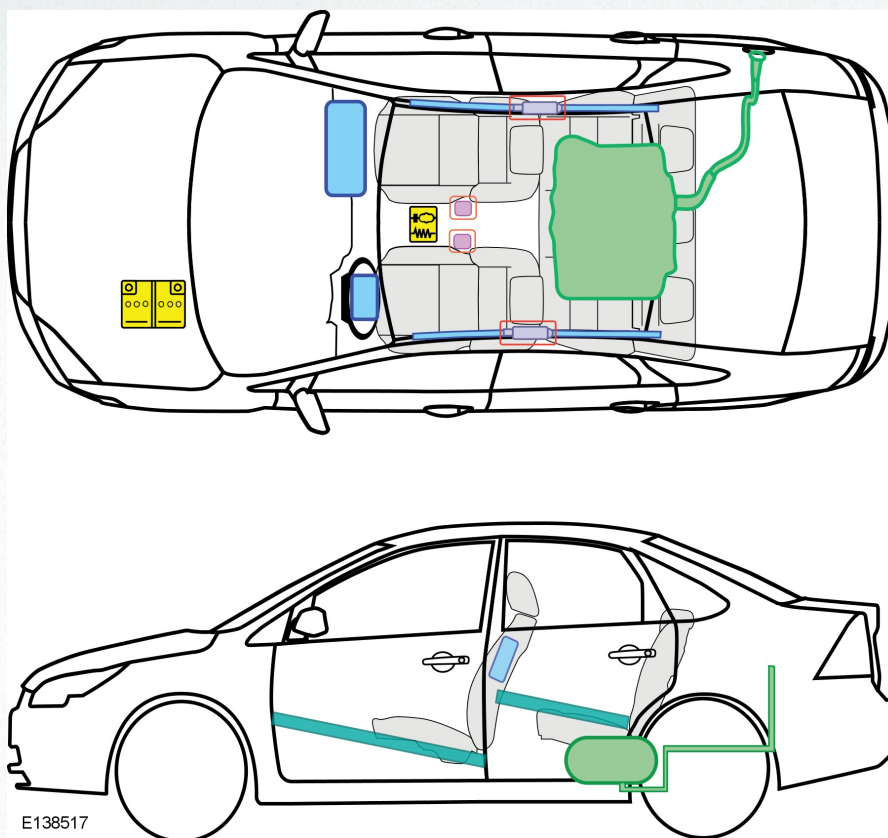



08/2007 – 03/2011

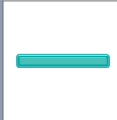

E138517

Legende

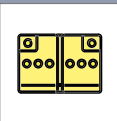
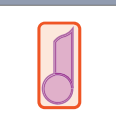
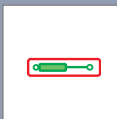
F

	Airbag		Karosseriever- stärkung		Steuergerät		Fussgänger- schutzsystem
	Gasgenerator		Überrollschutz- bügel		Batterie		
	Gurtstraffer		Gasdruck- dämpfer		Kraftstofftank		

(Stand : 03/2011)

FORD Focus

4-Türer

03/2011 – 09/2014

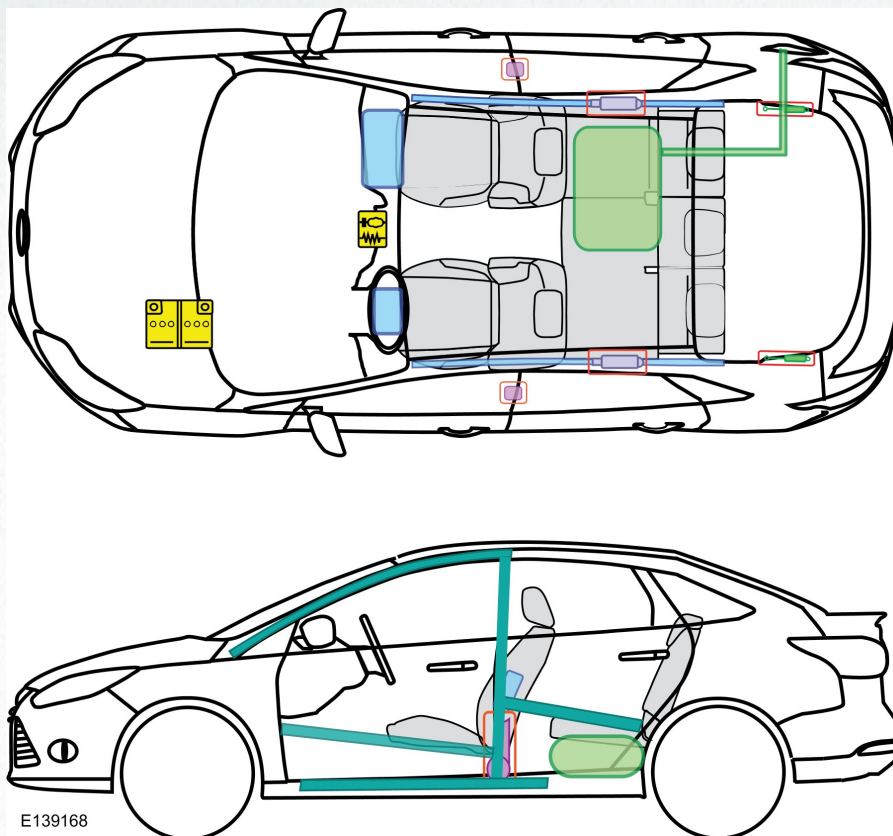

Legende

F

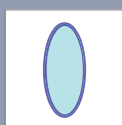

Airbag

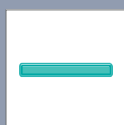

Karosseriever-
stärkung



Steuergerät



Fussgänger-
schutzsystem



Gasgenerator



Überrollschutz-
bügel

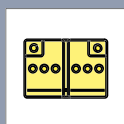

Batterie

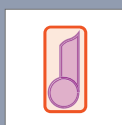

Gurtstraffer

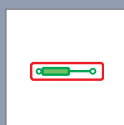

Gasdruck-
dämpfer



Kraftstofftank

(Stand : 10/2012)

FORD Focus

4-Türer

09/2014 – 04/2018

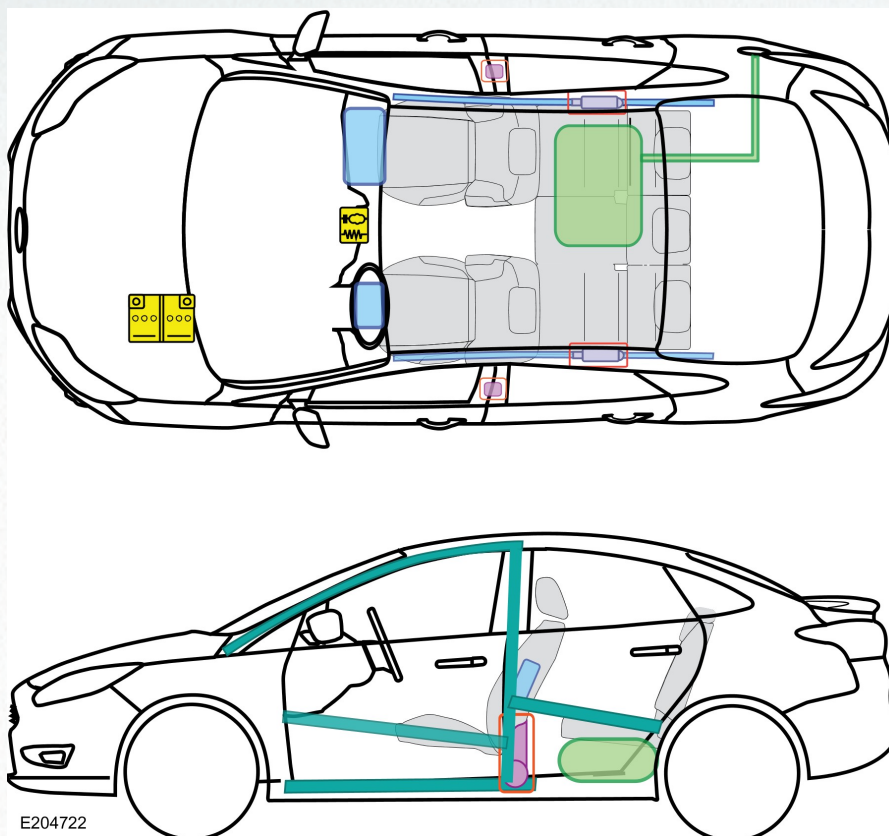

E204722

Legende

F

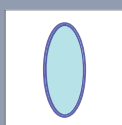

Airbag

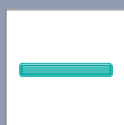

Karosseriever-
stärkung



Steuergerät



Fussgänger-
schutzsystem

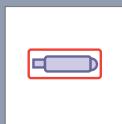

Gasgenerator



Überrollschutz-
bügel

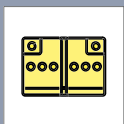

Batterie

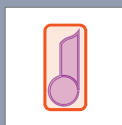

Gurtstraffer

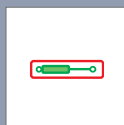

Gasdruck-
dämpfer



Kraftstofftank

(Stand : 12/2014)

FORD Focus

4-Türer

04/2018 – >



E279397

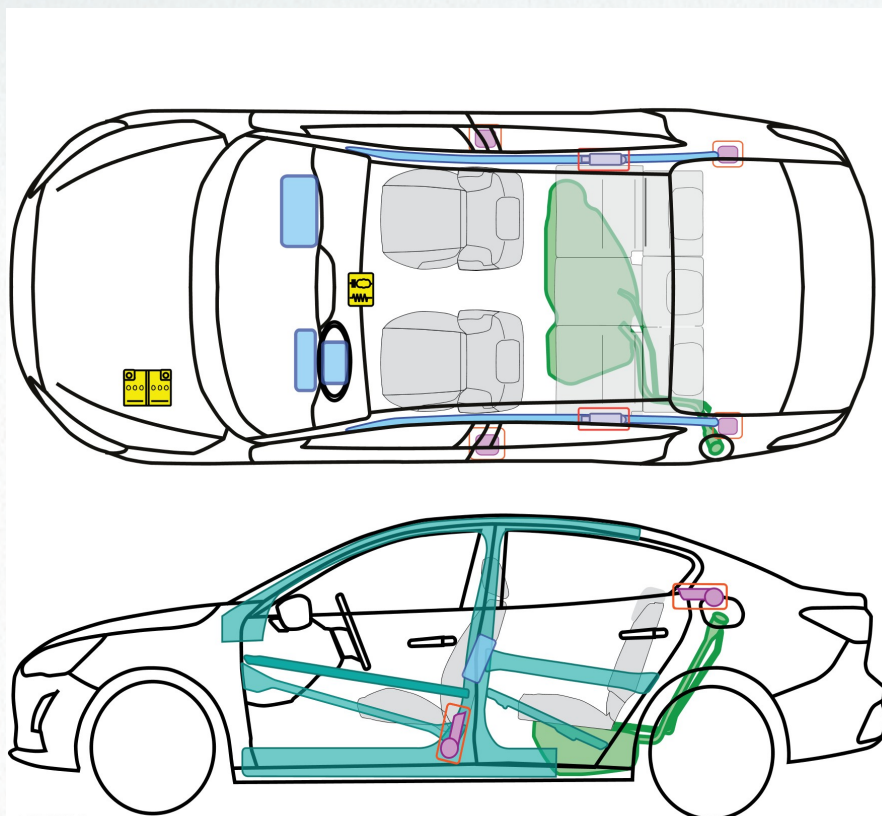

E279396

Legende

F

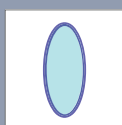

Airbag

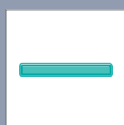

Karosseriever-
stärkung



Steuergerät



Fussgänger-
schutzsystem

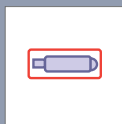

Gasgenerator



Überrollschutz-
bügel

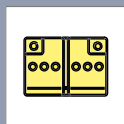

Batterie

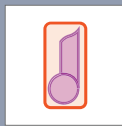

Gurtstraffer

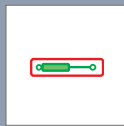

Gasdruck-
dämpfer



Kraftstofftank

(Stand : 01/2019)



FORD Focus





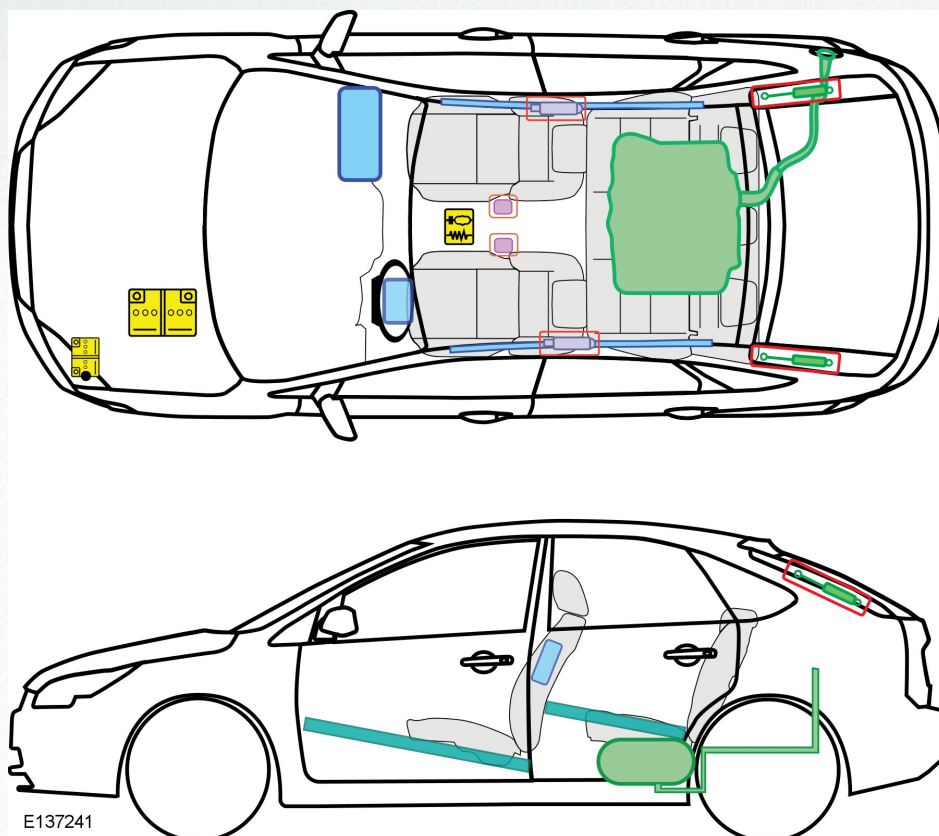

5-Türer

08/2007 – 03/2011

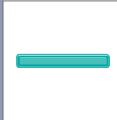

Legende

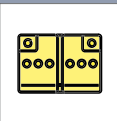
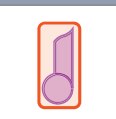
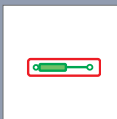
F

	Airbag		Karosseriever- stärkung		Steuergerät		Fussgänger- schutzsystem
	Gasgenerator		Überrollschutz- bügel		Batterie		
	Gurtstraffer		Gasdruck- dämpfer		Kraftstofftank		

(Stand : 01/2011)

FORD Focus

5-Türer

08/1998 – 12/2004

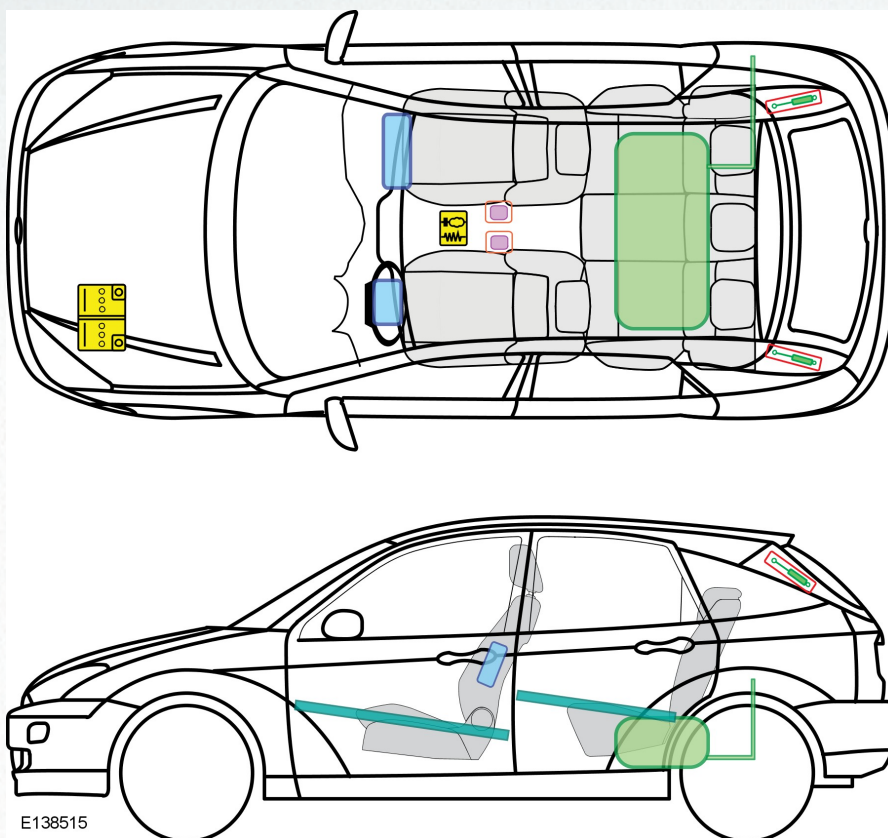

Legende

F

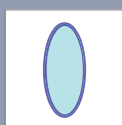

Airbag

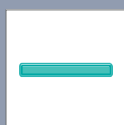

Karosseriever-
stärkung



Steuergerät



Fussgänger-
schutzsystem

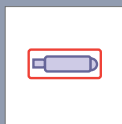

Gasgenerator

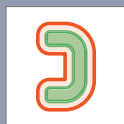

Überrollschutz-
bügel

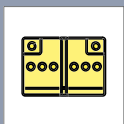

Batterie

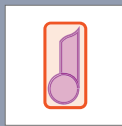

Gurtstraffer

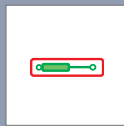

Gasdruck-
dämpfer



Kraftstofftank

(Stand : 03/2011)

FORD Focus

5-Türer

03/2011 – 09/2014



E139059

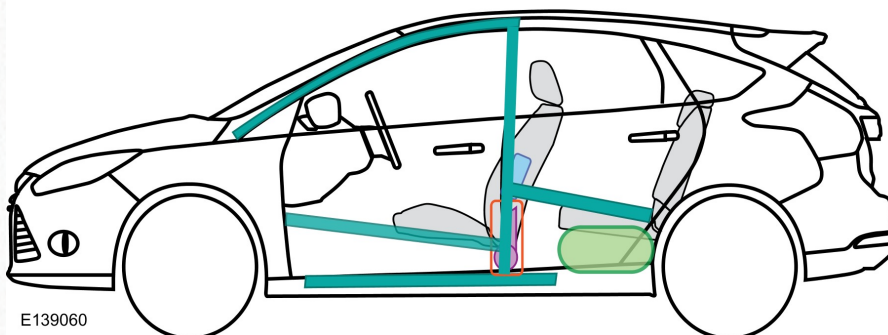
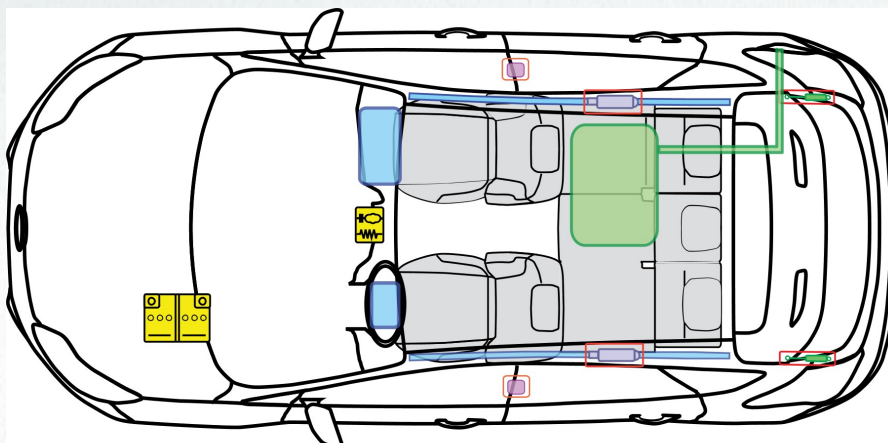

E139060

Legende

F

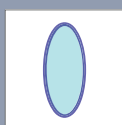

Airbag

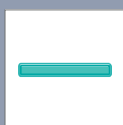

Karosseriever-
stärkung



Steuergerät



Fussgänger-
schutzsystem

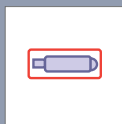

Gasgenerator



Überrollschutz-
bügel

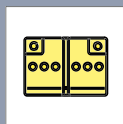

Batterie

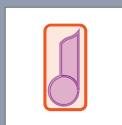

Gurtstraffer

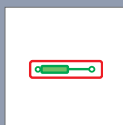

Gasdruck-
dämpfer



Kraftstofftank

(Stand : 10/2012)

FORD Focus

5-Türer

07/2004 – 08/2007

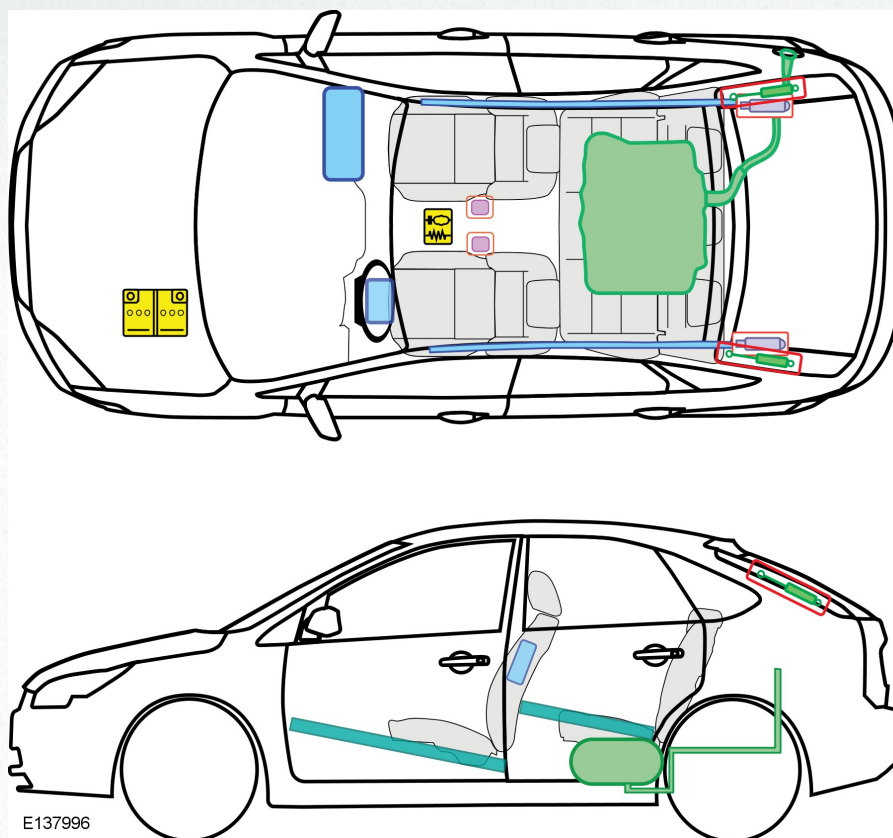

E137996

Legende

F

	Airbag		Karosseriever- stärkung		Steuergerät		Fussgänger- schutzsystem
	Gasgenerator		Überrollschutz- bügel		Batterie		
	Gurtstraffer		Gasdruck- dämpfer		Kraftstofftank		

(Stand : 03/2011)

FORD Focus

5-Türer

09/2014 – 04/2018



E203577

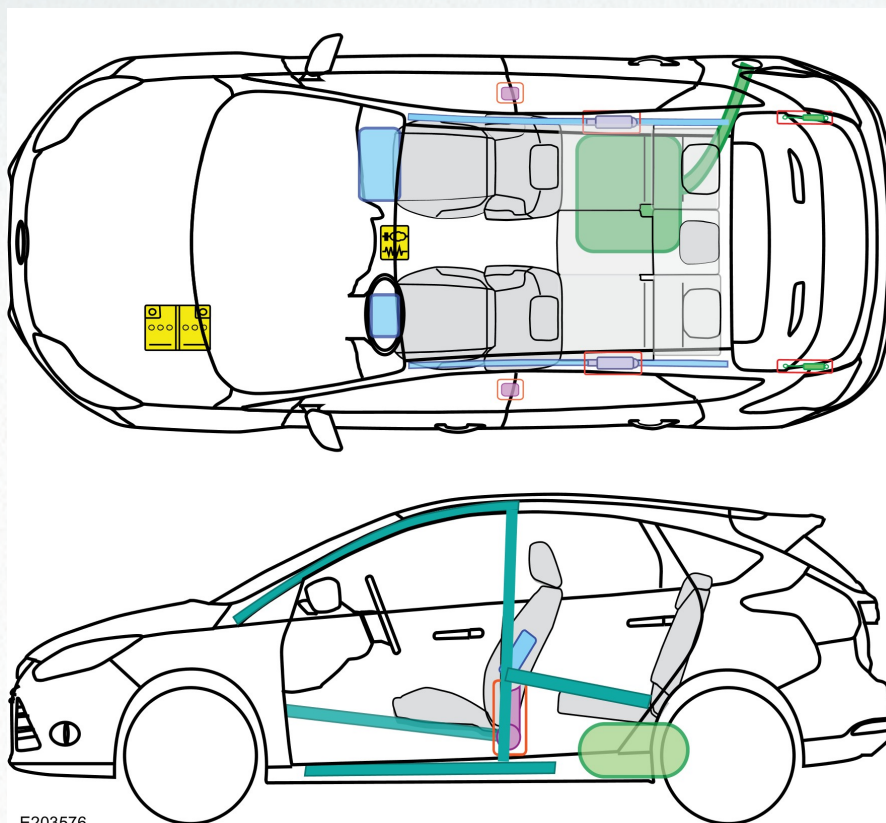

E203576

Legende

F

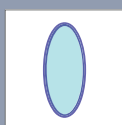

Airbag

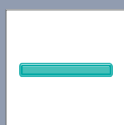

Karosseriever-
stärkung



Steuergerät



Fussgänger-
schutzsystem

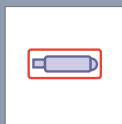

Gasgenerator

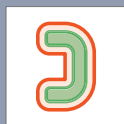

Überrollschutz-
bügel

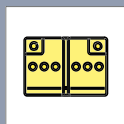

Batterie

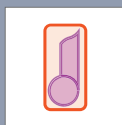

Gurtstraffer

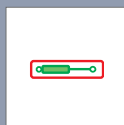

Gasdruck-
dämpfer



Kraftstofftank

(Stand : 12/2018)

FORD Focus

5-Türer

04/2018 – >

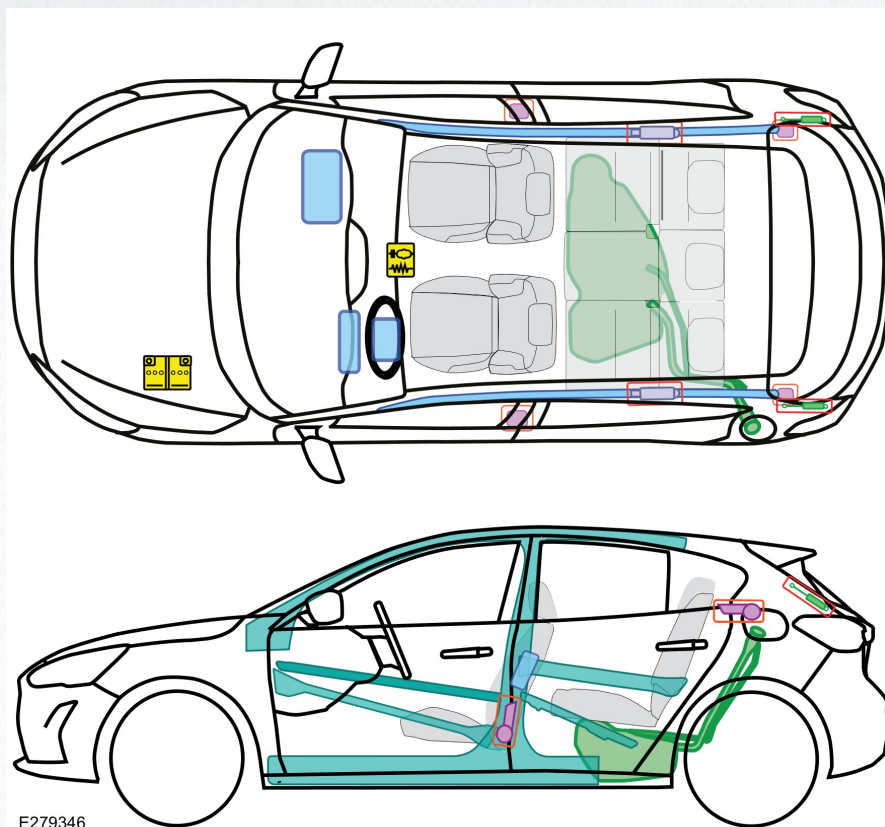

Legende

F

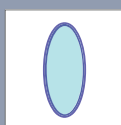

Airbag

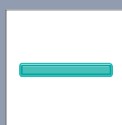

Karosseriever-
stärkung



Steuergerät



Fussgänger-
schutzsystem



Gasgenerator



Überrollschutz-
bügel

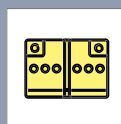

Batterie

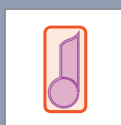

Gurtstraffer

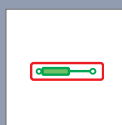

Gasdruck-
dämpfer



Kraftstofftank

(Stand : 01/2019)

FORD Focus - LPG

5-Türer

08/2007 – 03/2011

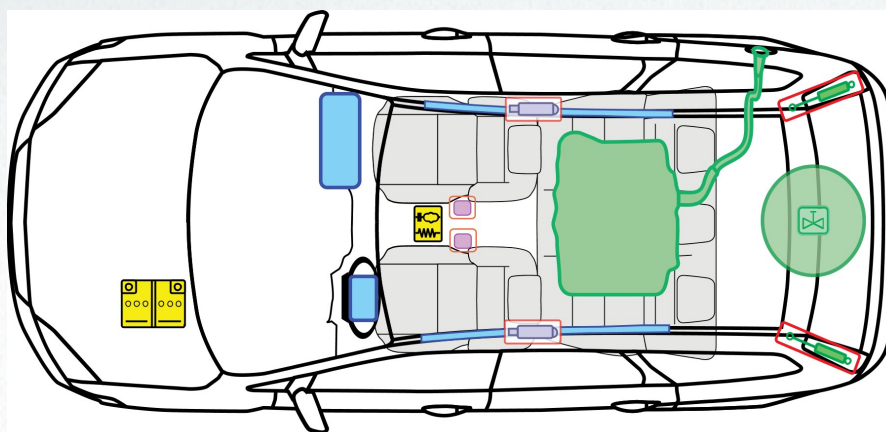



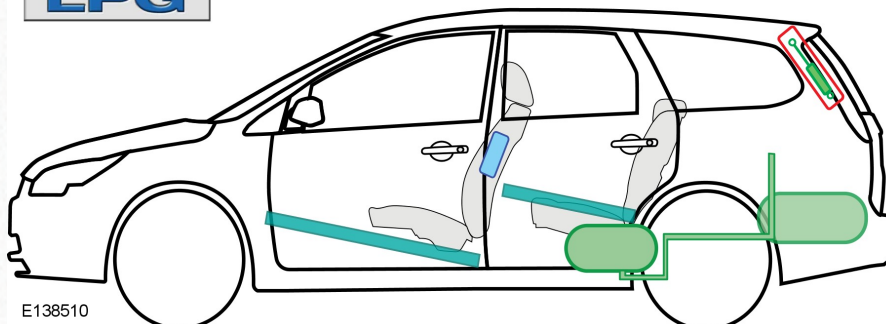





LPG

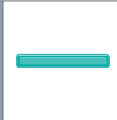

E138510

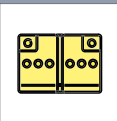
Legende

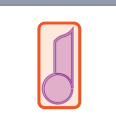
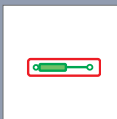
F

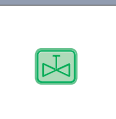
	Airbag		Karosseriever- stärkung		Steuergerät		Fussgänger- schutzsystem
	Gasgenerator		Überrollschutz- bügel		Batterie		Gastank
	Gurtstraffer		Gasdruck- dämpfer		Kraftstofftank		Sicherheits- ventil

(Stand : 03/2011)

FORD Focus - LPG

5-Türer

07/2004 – 08/2007

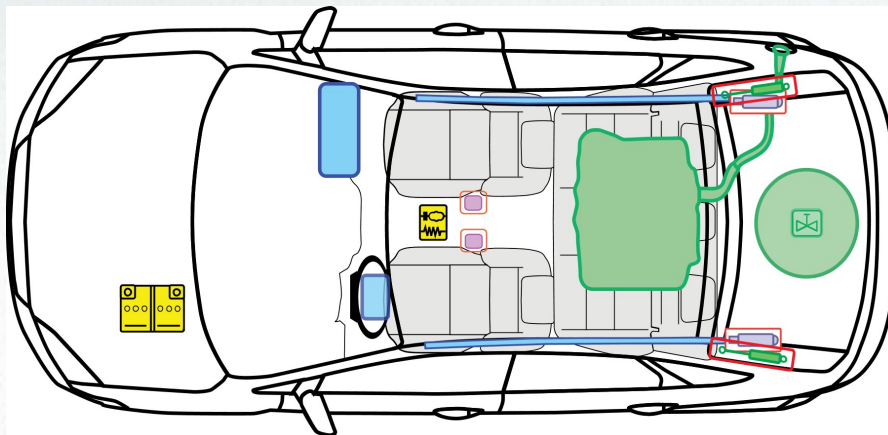

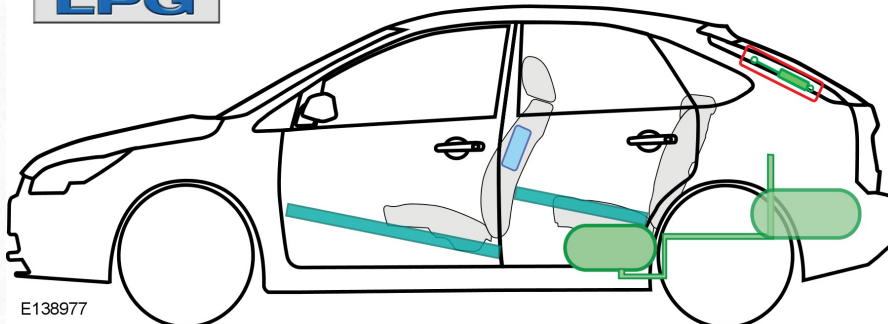

LPG



E138977

Legende

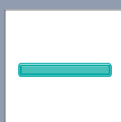
F

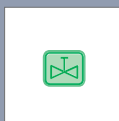
	Airbag		Karosseriever- stärkung		Steuergerät		Fussgänger- schutzsystem
	Gasgenerator		Überrollschutz- bügel		Batterie		Gastank
	Gurtstraffer		Gasdruck- dämpfer		Kraftstofftank		Sicherheits- ventil

(Stand : 03/2011)

FORD Focus - LPG

5-Türer

05/2012 – 09/2014



E139059

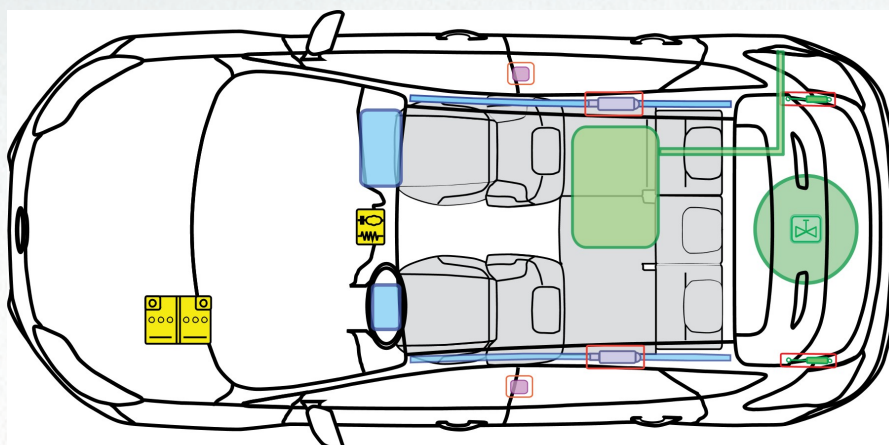

LPG

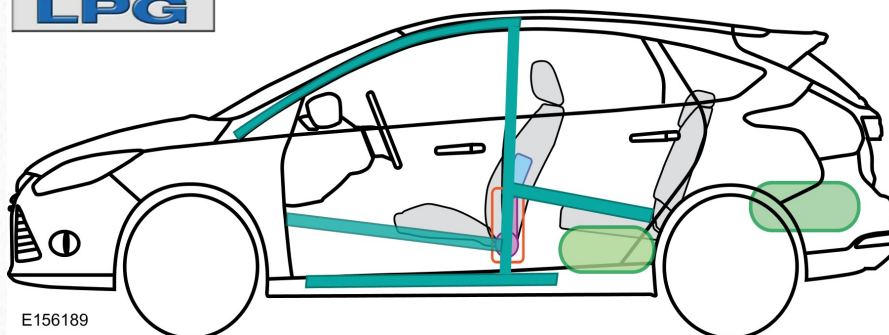

E156189

Legende

F

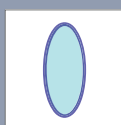

Airbag

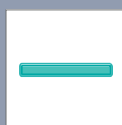

Karosseriever-
stärkung



Steuergerät



Fussgänger-
schutzsystem



Gasgenerator



Überrollschutz-
bügel

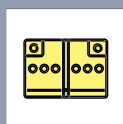

Batterie



Gastank

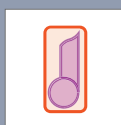

Gurtstraffer

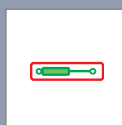

Gasdruck-
dämpfer



Kraftstofftank



Sicherheits-
ventil

(Stand : 10/2012)



FORD Focus - LPG

5-Türer

09/2014 – 04/2018



E203577

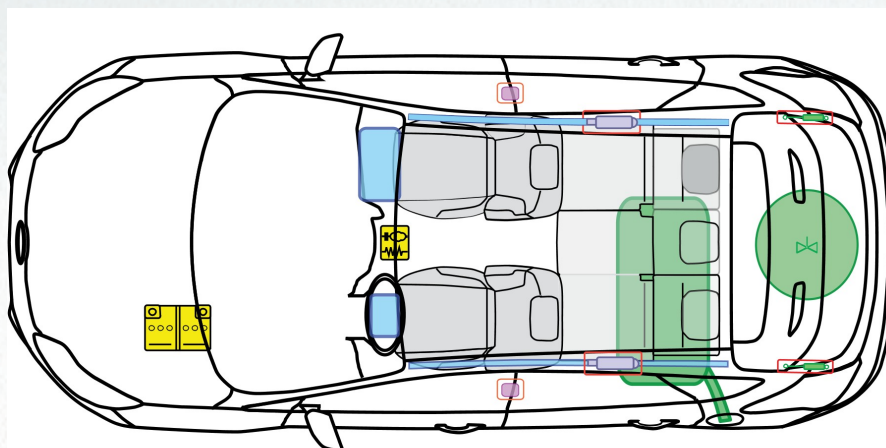



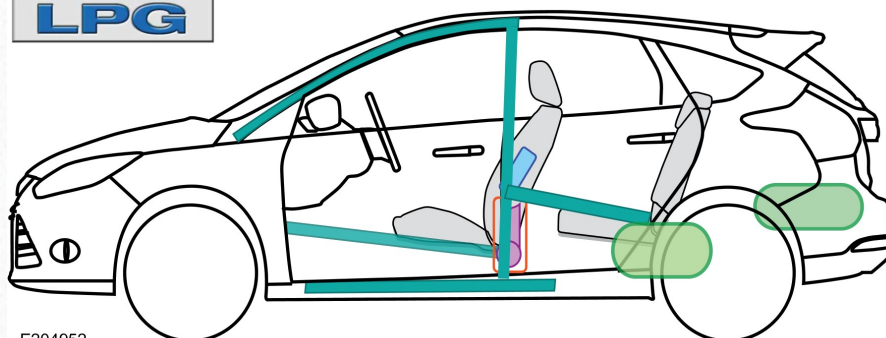





LPG

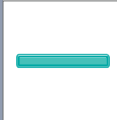

E204952

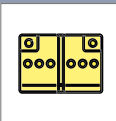
Legende

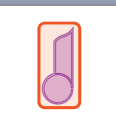
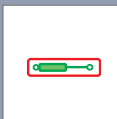
F

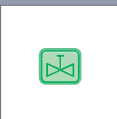
	Airbag		Karosseriever- stärkung		Steuergerät		Fussgänger- schutzsystem
	Gasgenerator		Überrollschutz- bügel		Batterie		Gastank
	Gurtstraffer		Gasdruck- dämpfer		Kraftstofftank		Sicherheits- ventil

(Stand : 12/2014)

FORD Focus - CNG

5-Türer

08/2007 – 03/2011

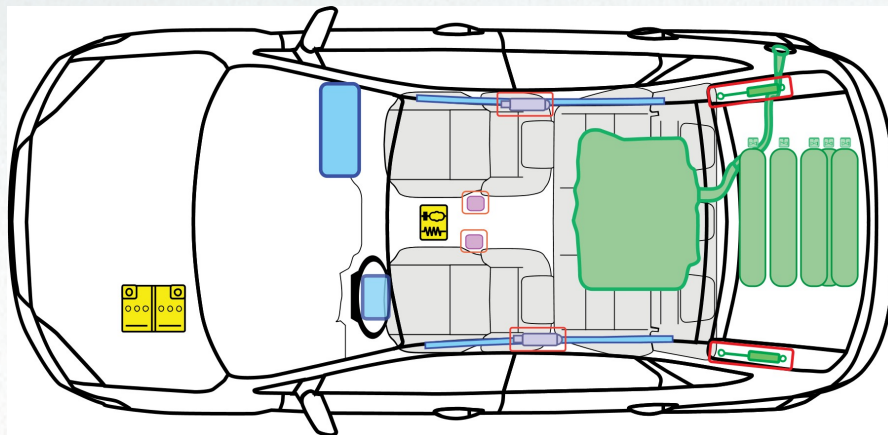



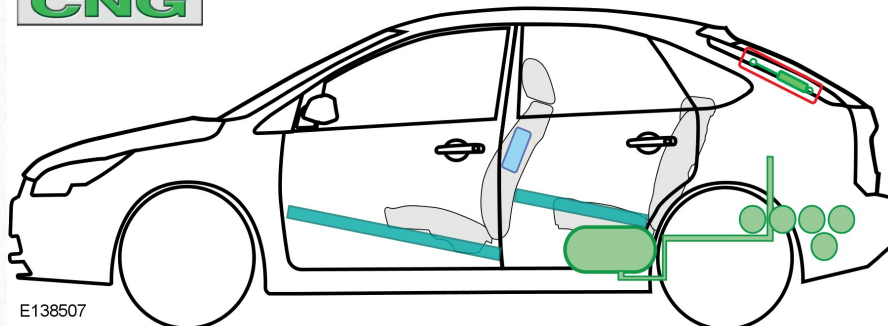

CNG



E138507

Legende

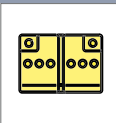
F

	Airbag		Karosseriever- stärkung		Steuergerät		Fussgänger- schutzsystem
	Gasgenerator		Überrollschutz- bügel		Batterie		Gastank
	Gurtstraffer		Gasdruck- dämpfer		Kraftstofftank		Sicherheits- ventil

(Stand : 03/2011)

FORD Focus - CNG

5-Türer

07/2004 – 08/2007

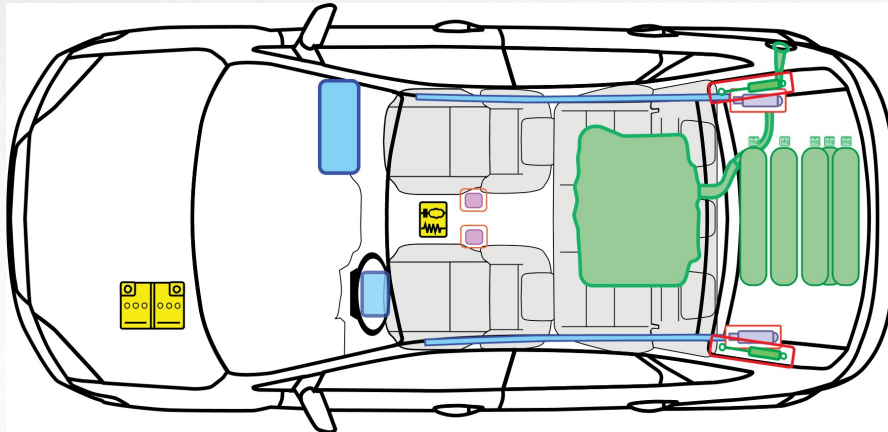

CNG

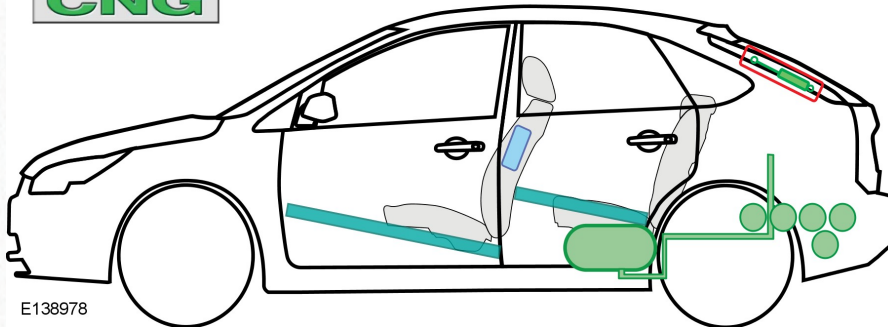

E138978

Legende

F

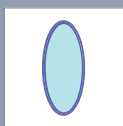

Airbag

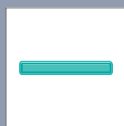

Karosseriever-
stärkung



Steuergerät



Fussgänger-
schutzsystem

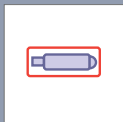

Gasgenerator



Überrollschutz-
bügel

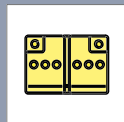

Batterie



Gastank

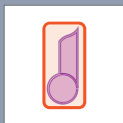

Gurtstraffer

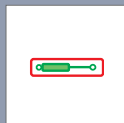

Gasdruck-
dämpfer



Kraftstofftank

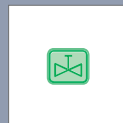

Sicherheits-
ventil

(Stand : 03/2011)

FORD Focus

Cabrio

03/2007 – 07/2010



E137308

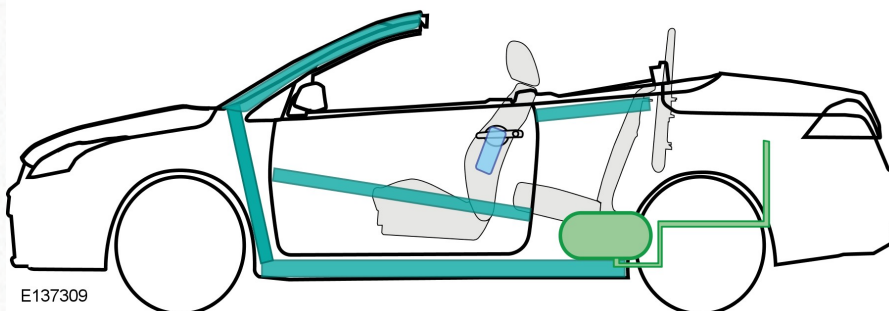
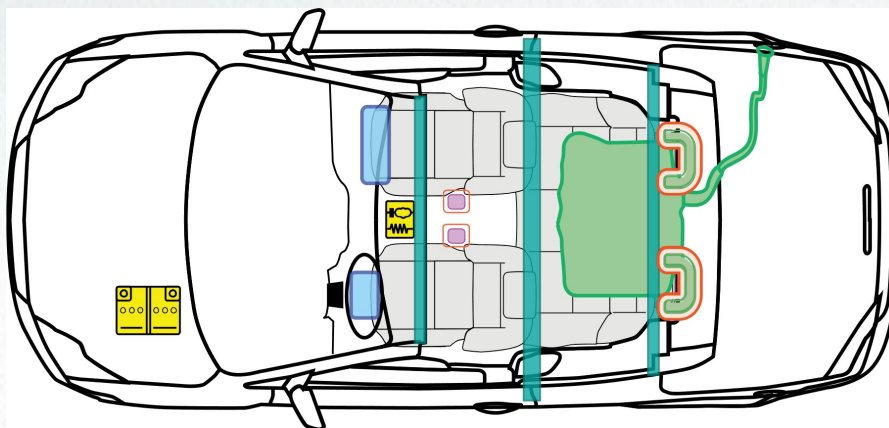

E137309

Legende

F

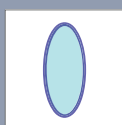

Airbag

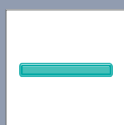

Karosseriever-
stärkung



Steuergerät



Fussgänger-
schutzsystem

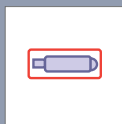

Gasgenerator



Überrollschutz-
bügel

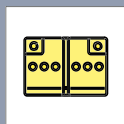

Batterie

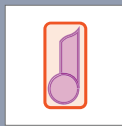

Gurtstraffer

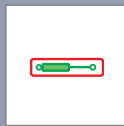

Gasdruck-
dämpfer



Kraftstofftank

(Stand : 03/2011)

FORD Focus

Turnier

07/2004 – 08/2007





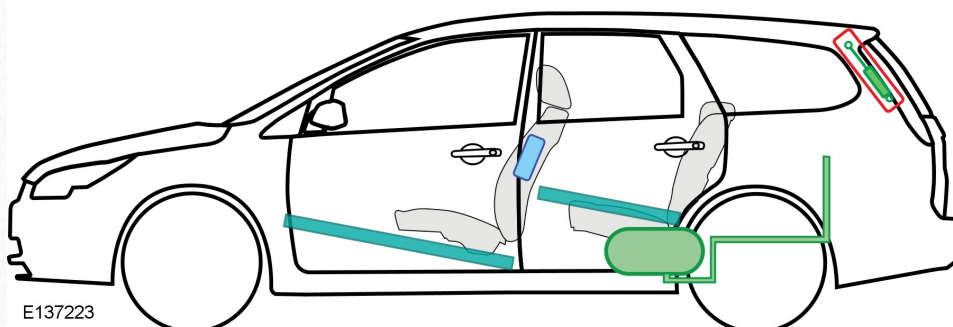
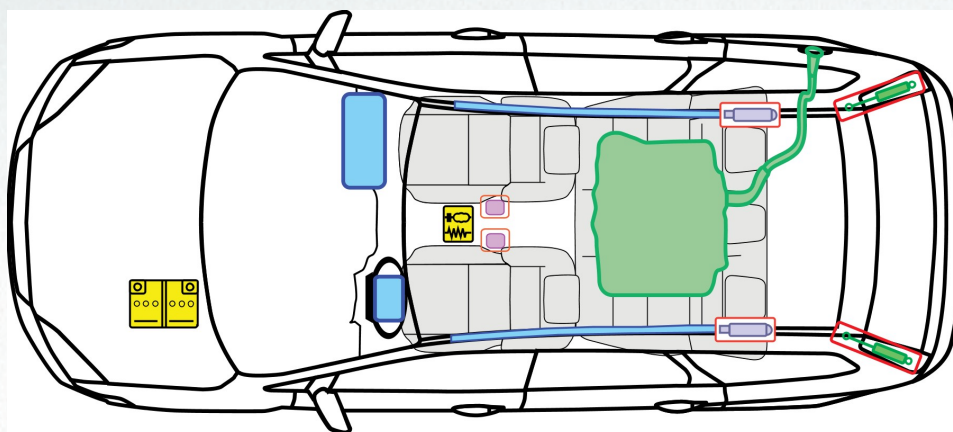



E137222

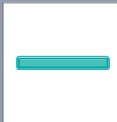

E137223

Legende

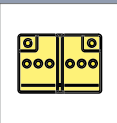
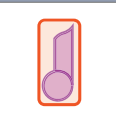
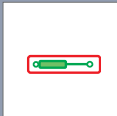
F

	Airbag		Karosseriever- stärkung		Steuergerät		Fussgänger- schutzsystem
	Gasgenerator		Überrollschutz- bügel		Batterie		
	Gurtstraffer		Gasdruck- dämpfer		Kraftstofftank		

(Stand : 03/2011)

FORD Focus

Turnier

08/2007 – 03/2011





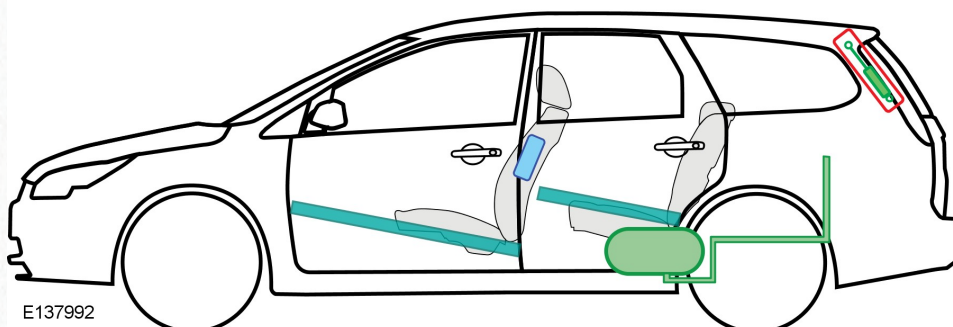
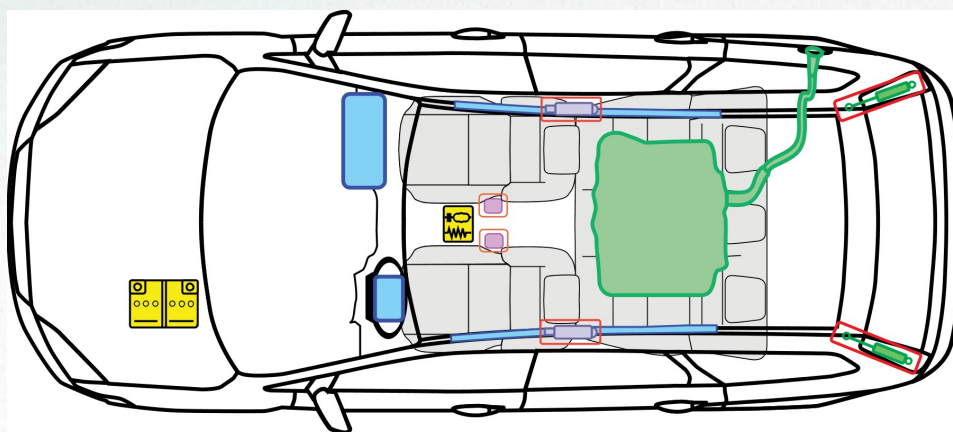



E137991

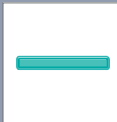

E137992

Legende

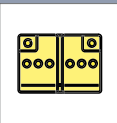
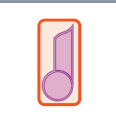
F

	Airbag		Karosseriever- stärkung		Steuergerät		Fussgänger- schutzsystem
	Gasgenerator		Überrollschutz- bügel		Batterie		
	Gurtstraffer		Gasdruck- dämpfer		Kraftstofftank		

(Stand : 02/2011)

FORD Focus

Turnier

08/1998 – 12/2004



E138505

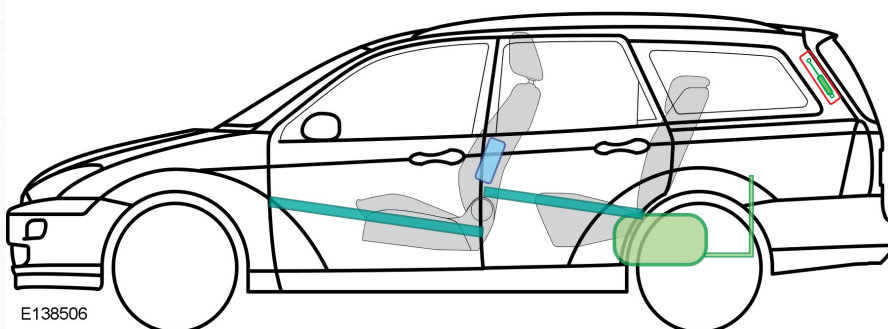
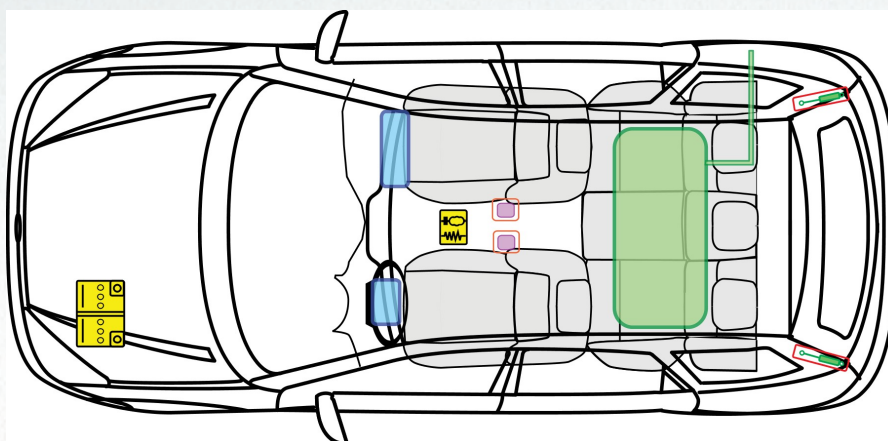

E138506

Legende

F

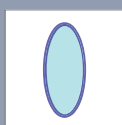

Airbag

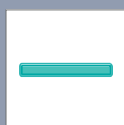

Karosseriever-
stärkung



Steuergerät



Fussgänger-
schutzsystem

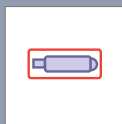

Gasgenerator



Überrollschutz-
bügel

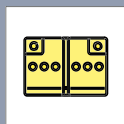

Batterie

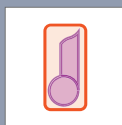

Gurtstraffer

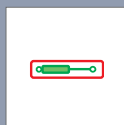

Gasdruck-
dämpfer



Kraftstofftank

(Stand : 03/2011)

FORD Focus

Turnier

03/2011 – 09/2014



E139114

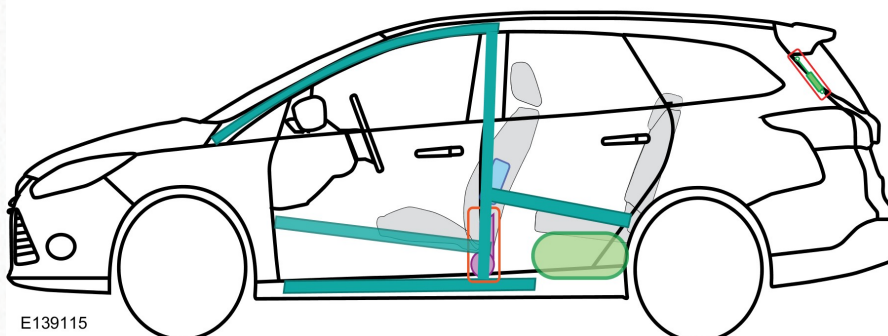
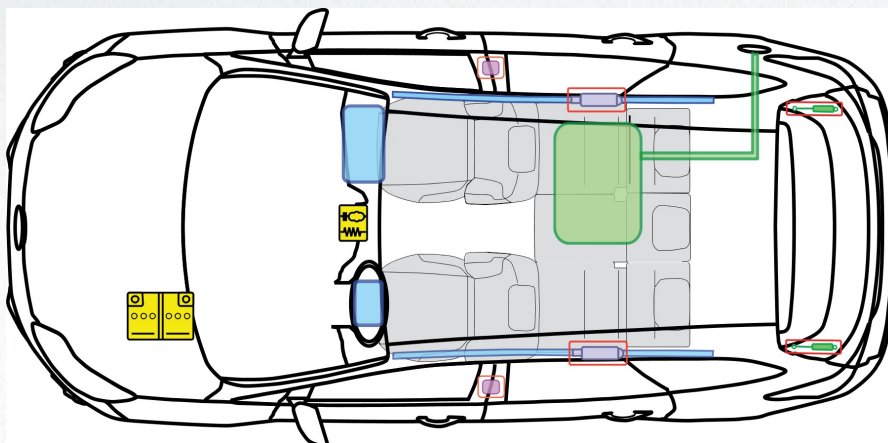

E139115

Legende

F

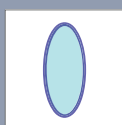

Airbag

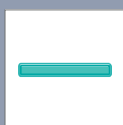

Karosseriever-
stärkung



Steuergerät



Fussgänger-
schutzsystem

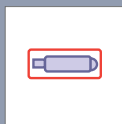

Gasgenerator



Überrollschutz-
bügel

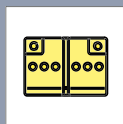

Batterie

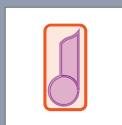

Gurtstraffer

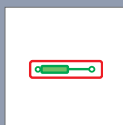

Gasdruck-
dämpfer



Kraftstofftank

(Stand : 10/2012)



FORD Focus

Turnier

09/2014 – 04/2018



E204439

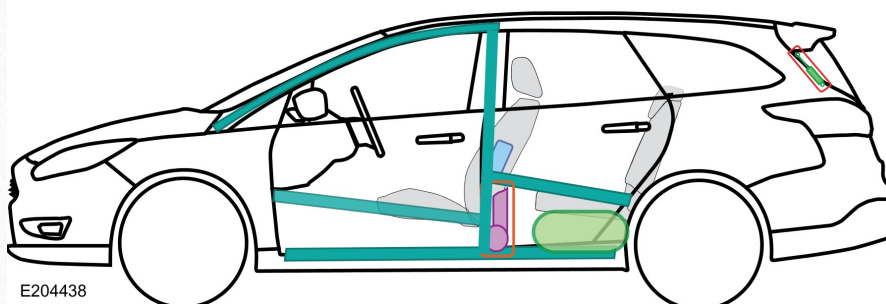
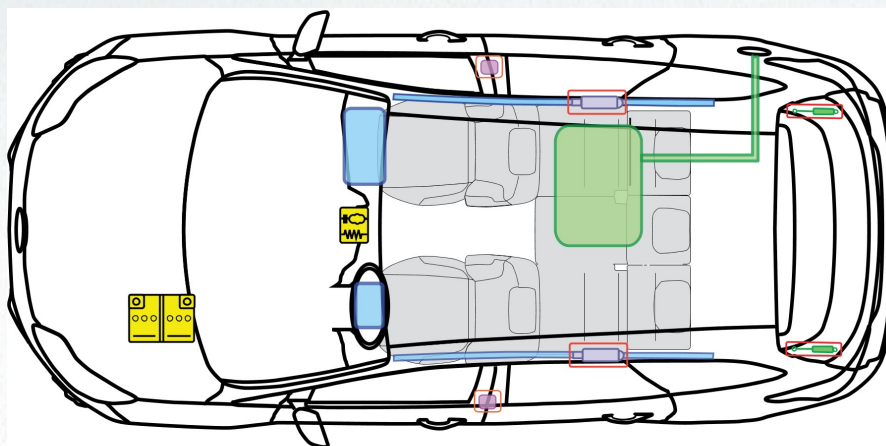

E204438

Legende

F

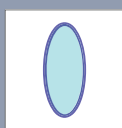

Airbag

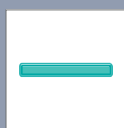

Karosseriever-
stärkung



Steuergerät



Fussgänger-
schutzsystem

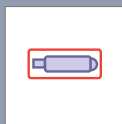

Gasgenerator



Überrollschutz-
bügel

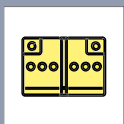

Batterie

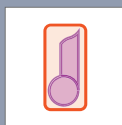

Gurtstraffer

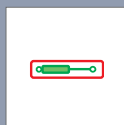

Gasdruck-
dämpfer



Kraftstofftank

(Stand : 12/2014)



FORD Focus

Turnier

04/2018 – >



E279011

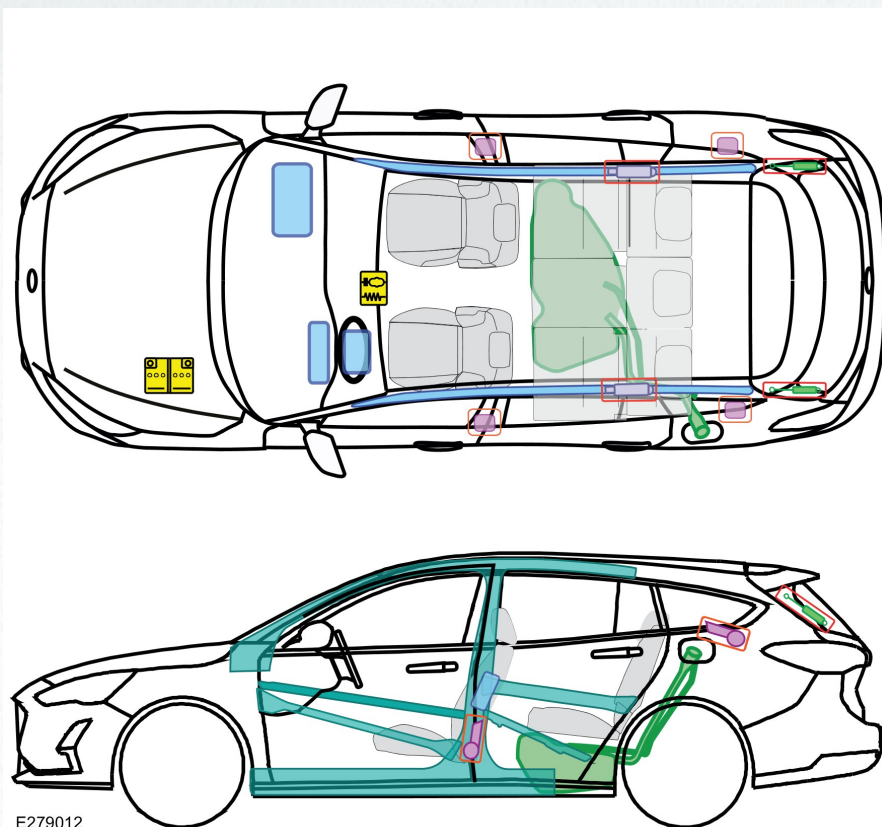

E279012

Legende

F

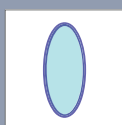

Airbag

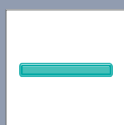

Karosseriever-
stärkung



Steuergerät



Fussgänger-
schutzsystem

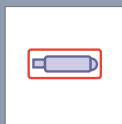

Gasgenerator

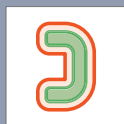

Überrollschutz-
bügel

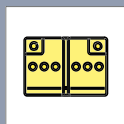

Batterie

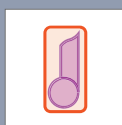

Gurtstraffer

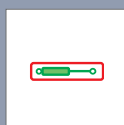

Gasdruck-
dämpfer



Kraftstofftank

(Stand : 01/2019)

FORD Focus - LPG

Turnier

08/2007 – 03/2011



E137991

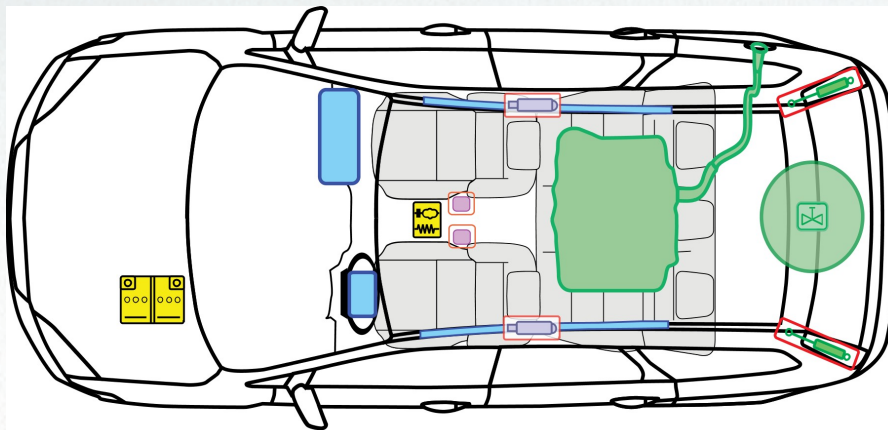



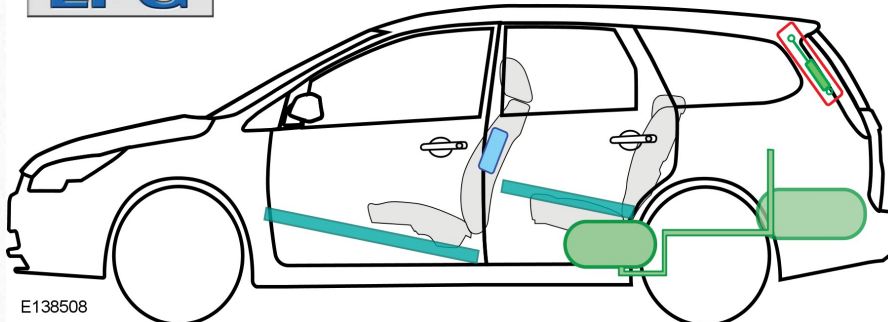





LPG

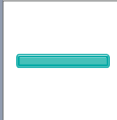

E138508

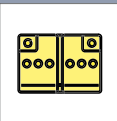
Legende

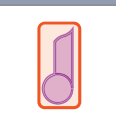
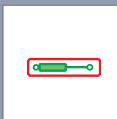
F

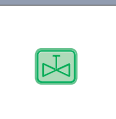
	Airbag		Karosseriever- stärkung		Steuergerät		Fussgänger- schutzsystem
	Gasgenerator		Überrollschutz- bügel		Batterie		Gastank
	Gurtstraffer		Gasdruck- dämpfer		Kraftstofftank		Sicherheits- ventil

(Stand : 03/2011)

FORD Focus - LPG

Turnier

07/2004 – 08/2007



E137222

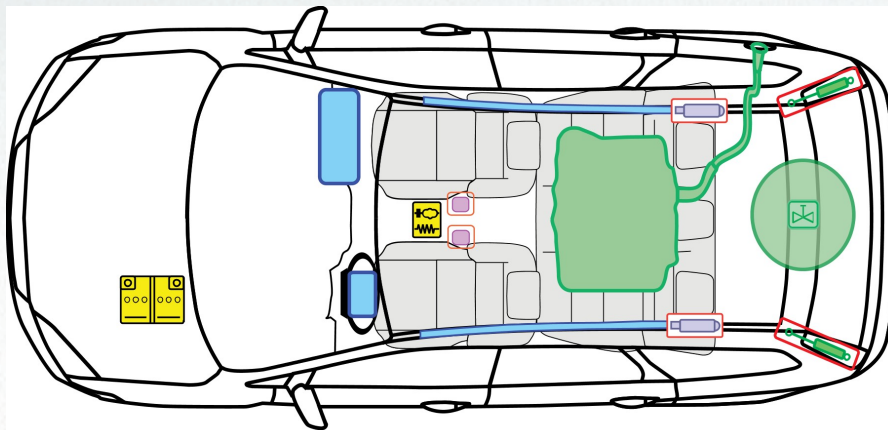

LPG

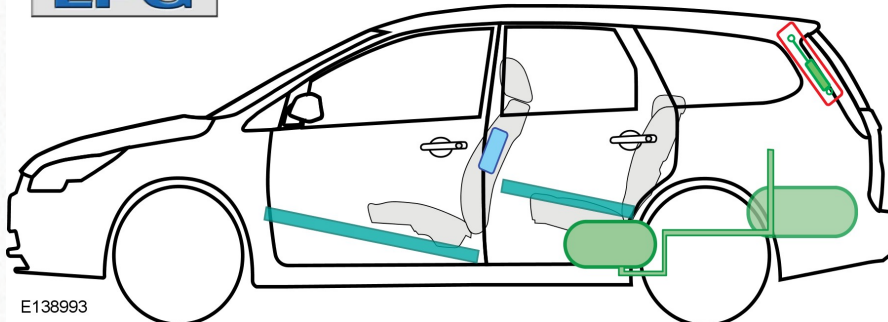

E138993

Legende

F

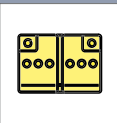
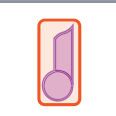
	Airbag		Karosseriever- stärkung		Steuergerät		Fussgänger- schutzsystem
	Gasgenerator		Überrollschutz- bügel		Batterie		Gastank
	Gurtstraffer		Gasdruck- dämpfer		Kraftstofftank		Sicherheits- ventil

(Stand : 03/2011)

FORD Focus - LPG

Turnier

05/2012 – 09/2014

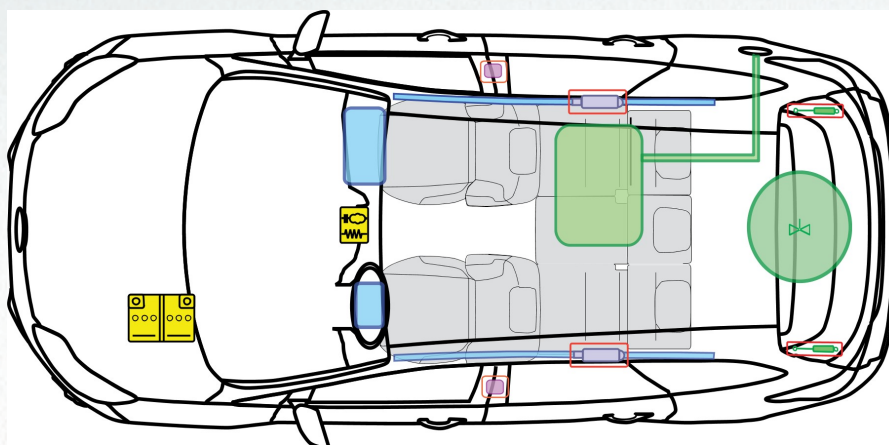

LPG

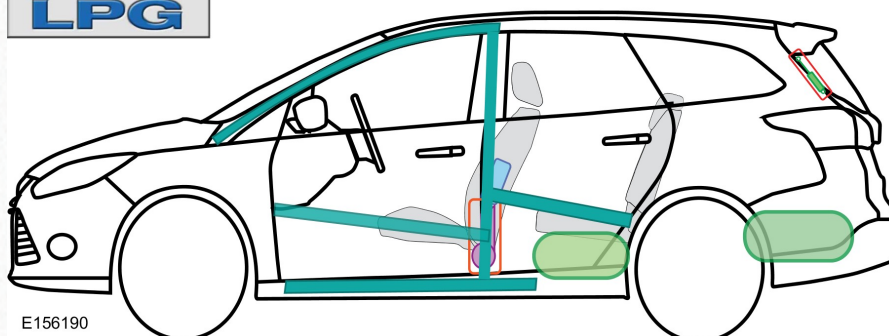

E156190

Legende

F

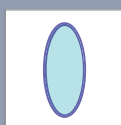

Airbag

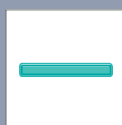

Karosseriever-
stärkung



Steuergerät



Fussgänger-
schutzsystem



Gasgenerator



Überrollschutz-
bügel

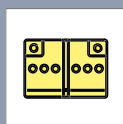

Batterie



Gastank

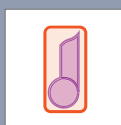

Gurtstraffer

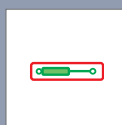

Gasdruck-
dämpfer



Kraftstofftank



Sicherheits-
ventil

(Stand : 07/2013)

FORD Focus - LPG

Turnier

09/2014 – 04/2018



E204439

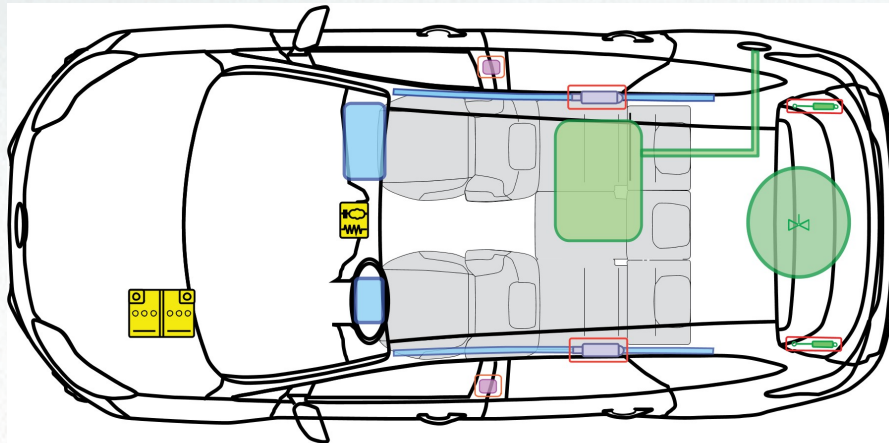

LPG

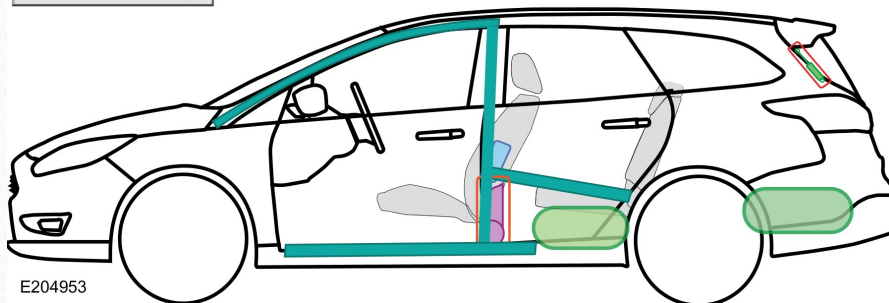

E204953

Legende

F

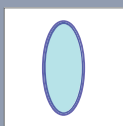

Airbag

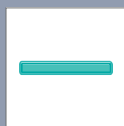

Karosseriever-
stärkung



Steuergerät



Fussgänger-
schutzsystem

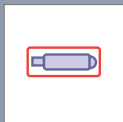

Gasgenerator

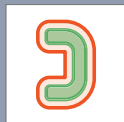

Überrollschutz-
bügel

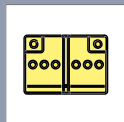

Batterie



Gastank

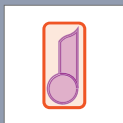

Gurtstraffer

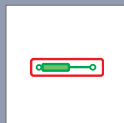

Gasdruck-
dämpfer



Kraftstofftank



Sicherheits-
ventil

(Stand : 12/2014)

FORD Focus E=LECTRIC

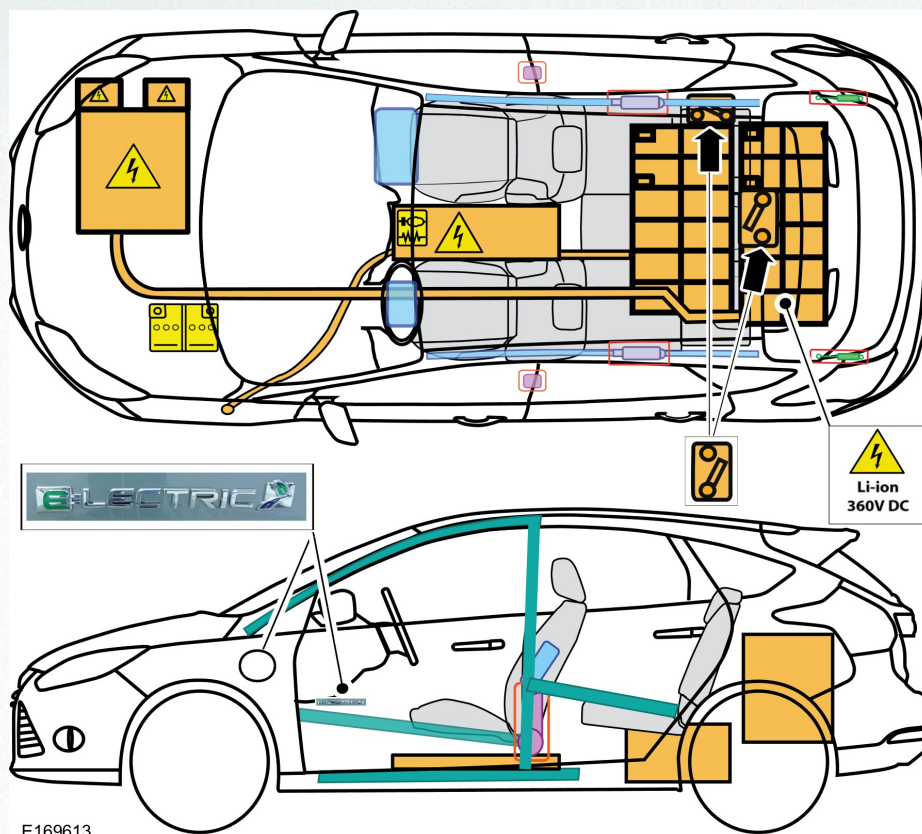

Legende

F

	Airbag		Karosseriever- stärkung		Steuergerät		Hochvoltbat- terie		Fussgänger- schutzsystem
	Gasgenerator		Überrollschutz- bügel		Hochvoltkom- ponenten		Hochvolt- leitung/ komponenten		
	Gurtstraffer		Gasdruck- dämpfer		Mechanischer Sensor		Hochvolttrenn- stelle		

(Stand : 05/2014)



HOCHVOLTSYSTEM-Deaktivierung

Vorwort

ES IST IMMER DAVON AUSZUGEHEN; DASS DAS HOCHVOLTSYSTEM DES FAHRZEUGS IN BETRIEB IST!

VOR ARBEITEN AM FAHRZEUG SICHERSTELLEN, DASS EXTERNE STROMVERSORGUNGEN GETRENNT SIND (z. B. Ladegeräte, Elektrowerkzeuge). Nichtbeachten dieser Anweisungen kann zu schweren oder tödlichen Verletzungen führen.

ELEKTROFAHRZEUG-IDENTIFIZIERUNGSNUMMER

Identifizierung anhand von Fahrzeugmerkmalen



E171275

1. Schild E=LECTRIC an beiden Türen vorn und an der Heckklappe
2. HOCHVOLT-Ladeanschluss (im Kotflügel links integriert)
3. Kein Auspuffsystem
4. Keine Tankklappe (normalerweise auf der rechten Seite)

Identifizierung anhand von Merkmalen des Motorraums

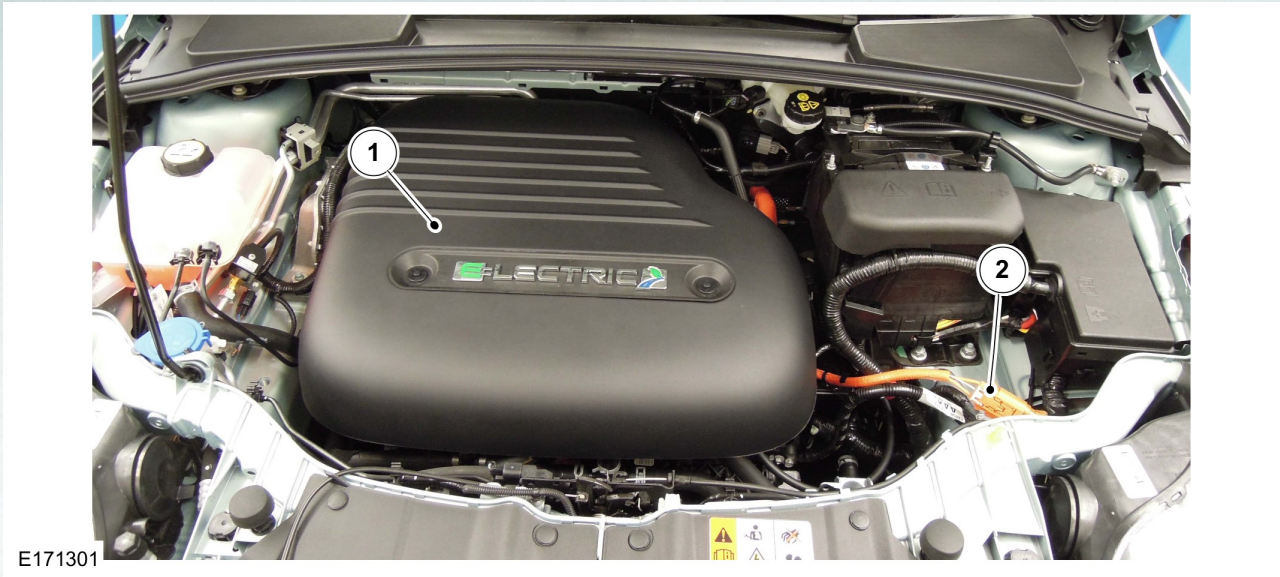

E171301

1. Obere Motorabdeckung E=LECTRIC
2. Orangefarbener Hochspannungs-Kabelstrang

FUNKTIONEN ZUM TRENNEN DER HOCHVOLTVERSORUNG

⚠ ACHTUNG: Bei Elektrofahrzeugen, die durch einen Unfall beschädigt wurden, besteht Gefahr durch Hochspannungsstromschlag, weil unter Umständen die Hochvolt-Sicherheitssysteme defekt sind. Vorsicht anwenden und geeignete persönliche Schutzausrüstung tragen. Alle metallhaltigen Schmuckgegenstände wie beispielsweise Uhren und Ringe abnehmen. Nichtbeachten dieser Anweisungen kann zu schweren oder tödlichen Verletzungen führen.

Zündung ist in Position AUS — Wenn die Zündung in Position AUS ist (und das Fahrzeug nicht geladen wird), ist das Hochvoltssystem getrennt.

Trennen des Hochvoltsystems zu Wartungszwecken — Wenn einer der beiden Hochvolt-Servicestecker abgenommen ist, ist das Hochvoltssystem getrennt.

Deaktivierung

Methode 1

Falls kein Zugang zur Batterie möglich ist, mit Methode 2 fortfahren.

1. Das Hochvoltssystem auf Strom prüfen.



2. Wenn das Hochvoltssystem aktiv ist, den Startknopf einmal drücken.



3. Das Kabel der 12-V-Batterie abnehmen.

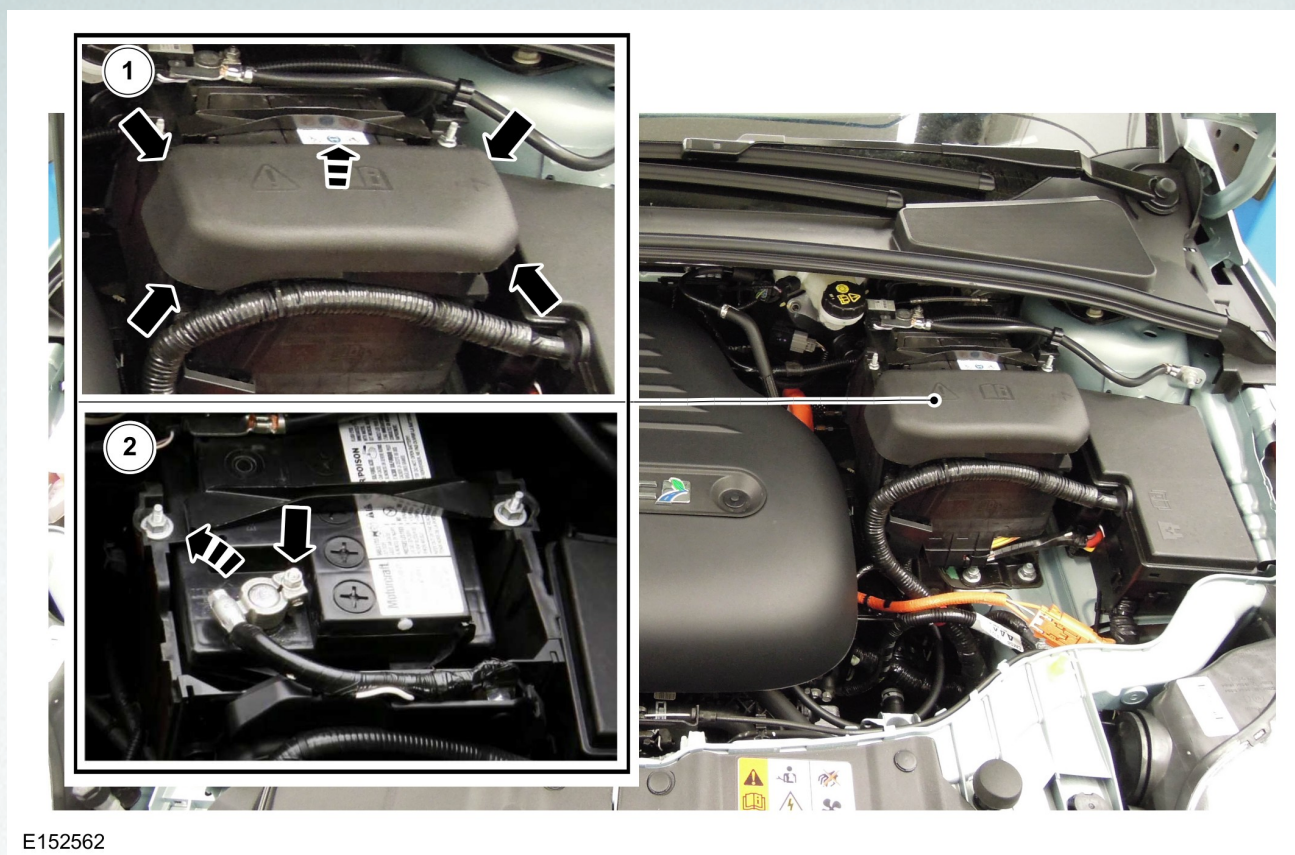

E152562

Methode 2

BEACHTEN: Für den Zugang zum oberen Hochvolt-Trennschalter der Batterie muss die geteilte Rücksitzlehne (60 %) heruntergeklappt werden.

Falls sich die Rücksitzlehne nicht herunterklappen lässt, mit Methode 3 fortfahren.

1. Den Sitzlehnen-Entriegelungshebel oben auf der Sitzlehne ermitteln.

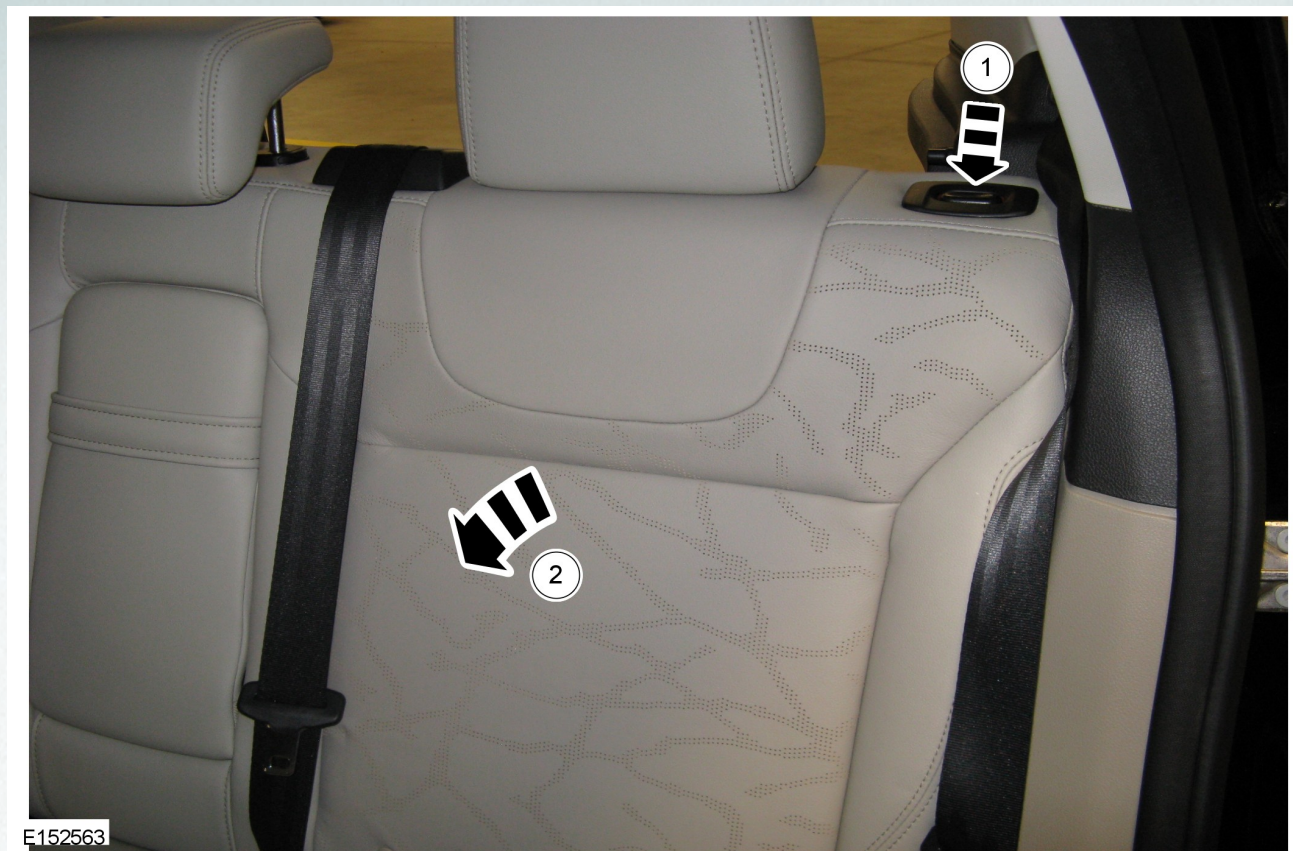

E152563

2. Abdeckung abnehmen, um Zugang zum oberen Batterieservicestecker zu erhalten.

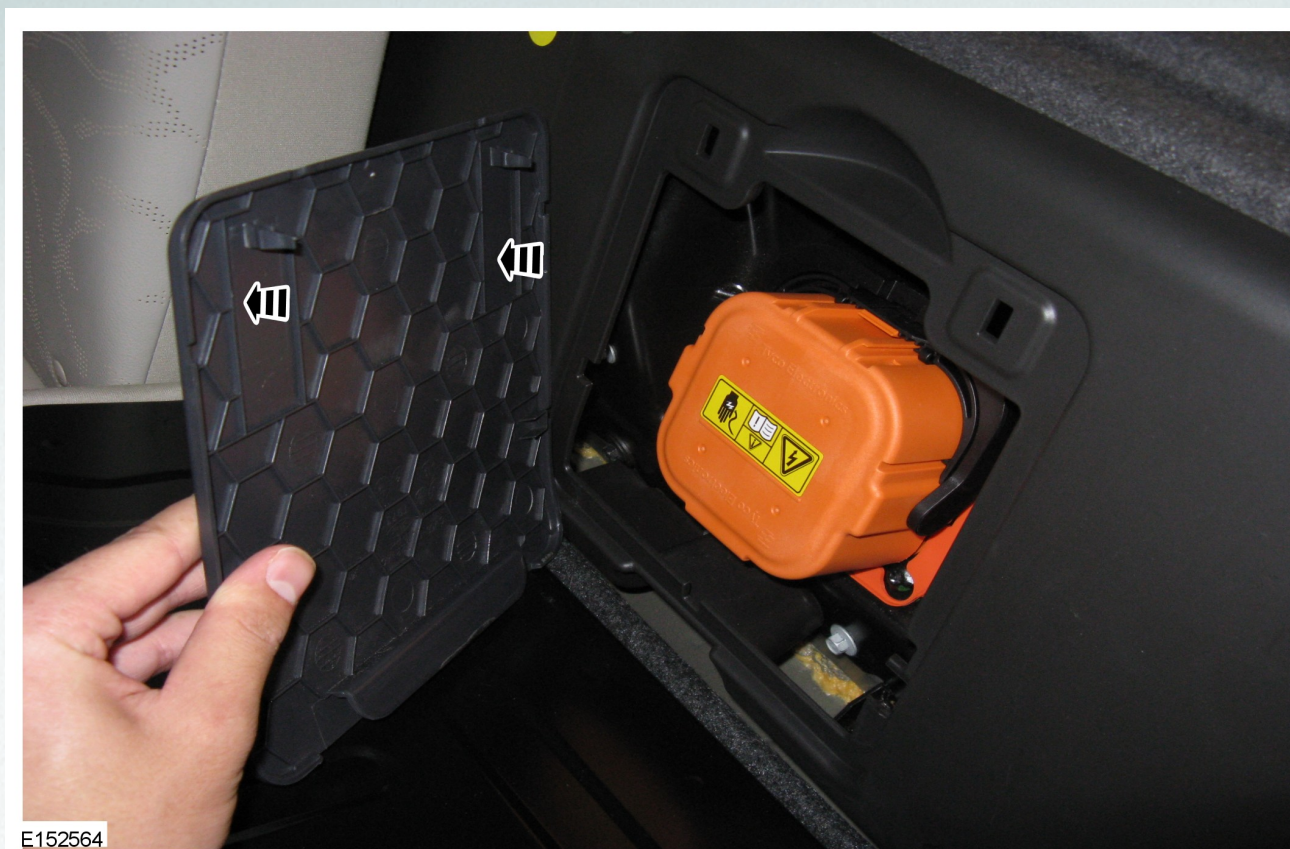

E152564

3. Den Freigabeknopf oben am Servicestecker drücken und den Öffnungshebel ungefähr 45 Grad nach unten drehen.



4. Den Freigabeknopf erneut drücken und den Griff um weitere 45 Grad in die vollständig geöffnete Position drehen. Am Griff ziehen, um den oberen Servicestecker abzunehmen.

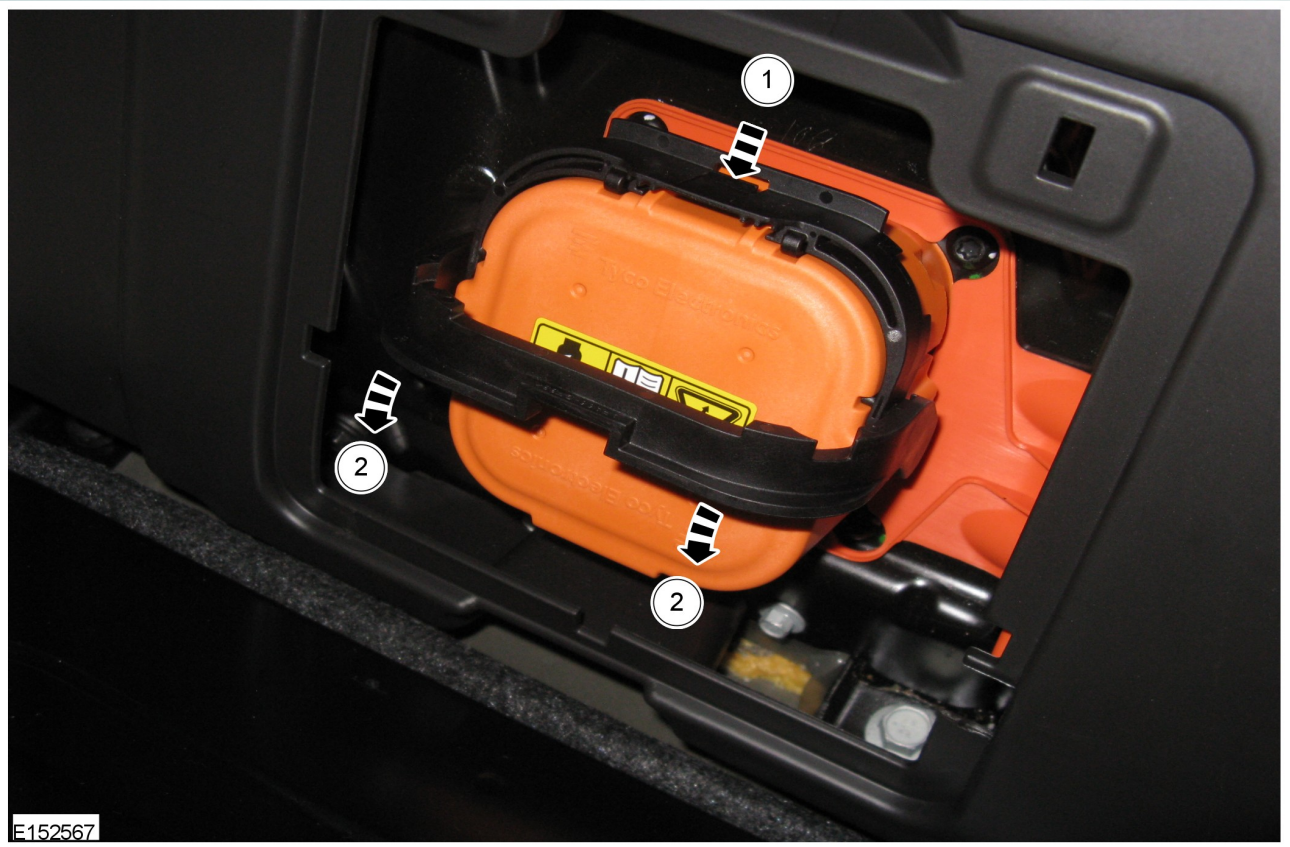

Methode 3

BEACHTEN: Der untere Servicestecker wird nach demselben Verfahren wie der obere entfernt. Für den Zugang zum unteren Hochspannungs-Serviceschalter der Batterie das Fahrzeug hinten mit einer geeigneten Hebevorrichtung anheben.

- 1. Der untere Hochspannungs-Serviceschalter der Batterie befindet sich auf der rechten Fahrzeugseite in der Nähe des Hinterreifens.**

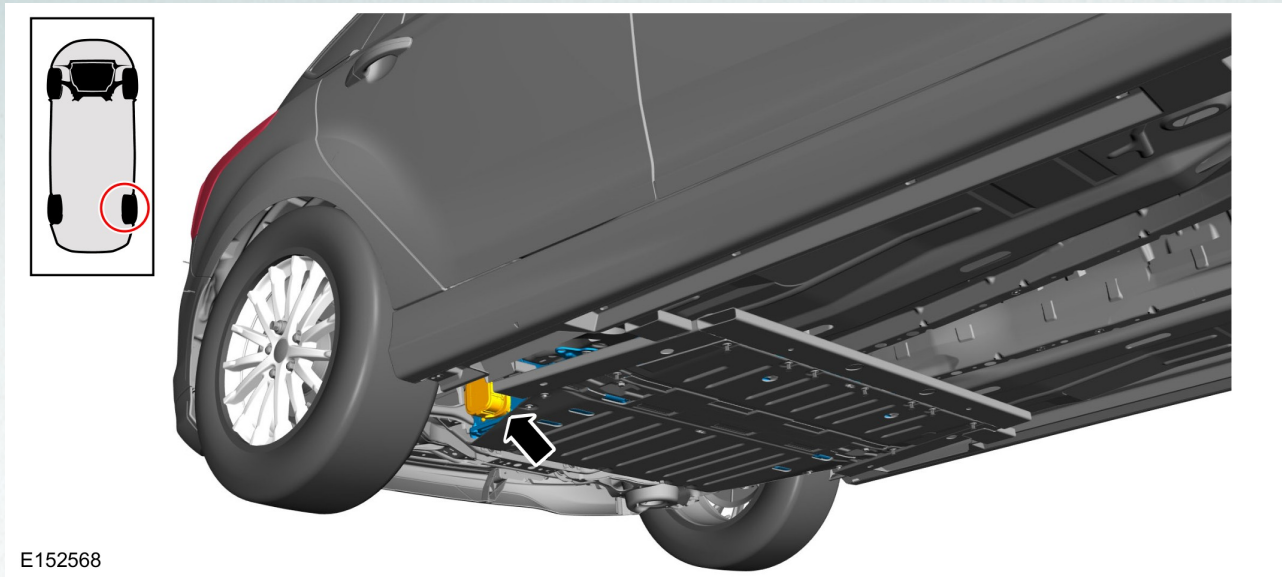

E152568

- 2. Den Halterung vom Feststellbremsseilzughalter abbauen und Feststellbremsseilzug und Halter weglegen. Den Freigabeknopf an der Rückseite des Servicesteckers drücken und den Öffnungshebel ungefähr 45 Grad zur Fahrzeugvorderseite drehen. Den Freigabeknopf erneut drücken und den**

Öffnungshebel um weitere 45 Grad in die vollständig geöffnete Position drehen. Am Griff ziehen, um den unteren Servicestecker abzunehmen.

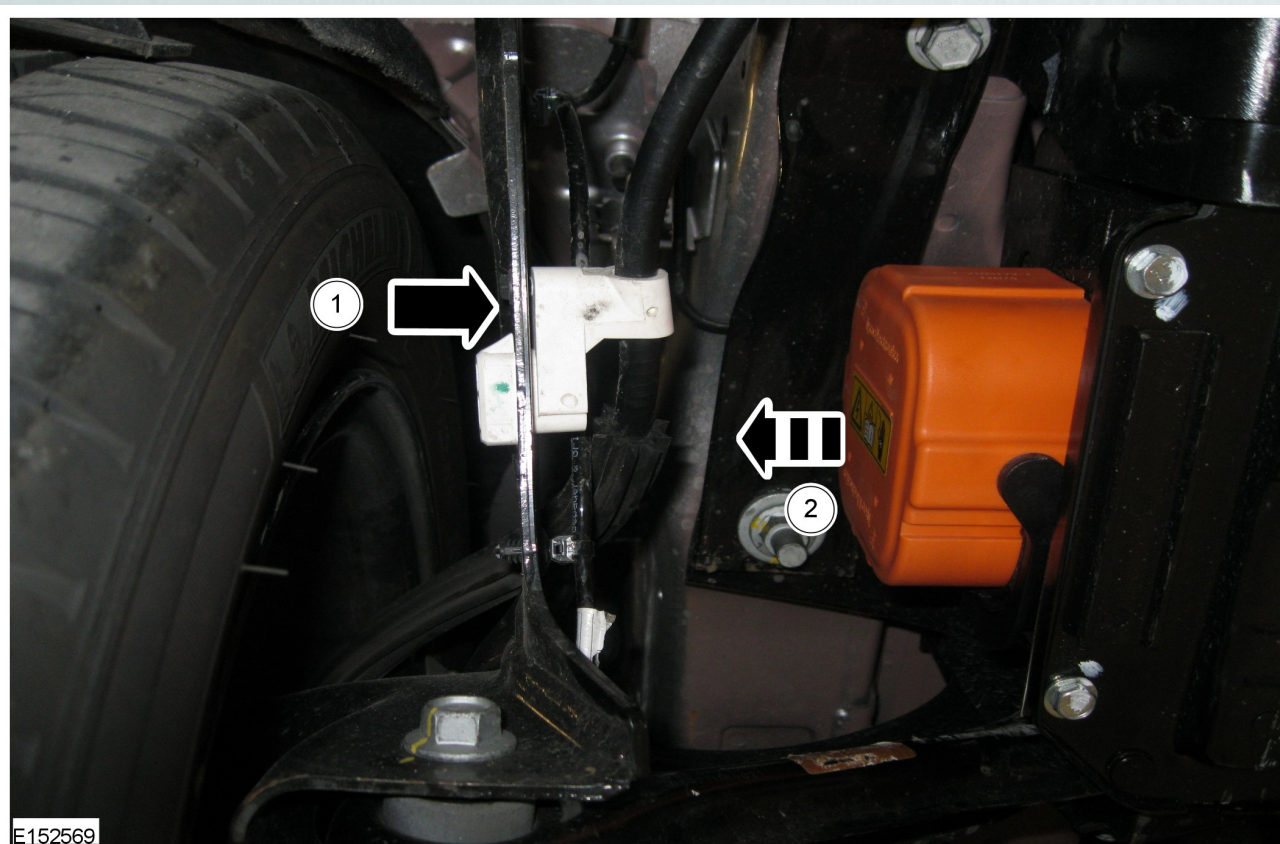

(Stand : 05/2014)

FORD Fusion

06/2002 – >



E137293

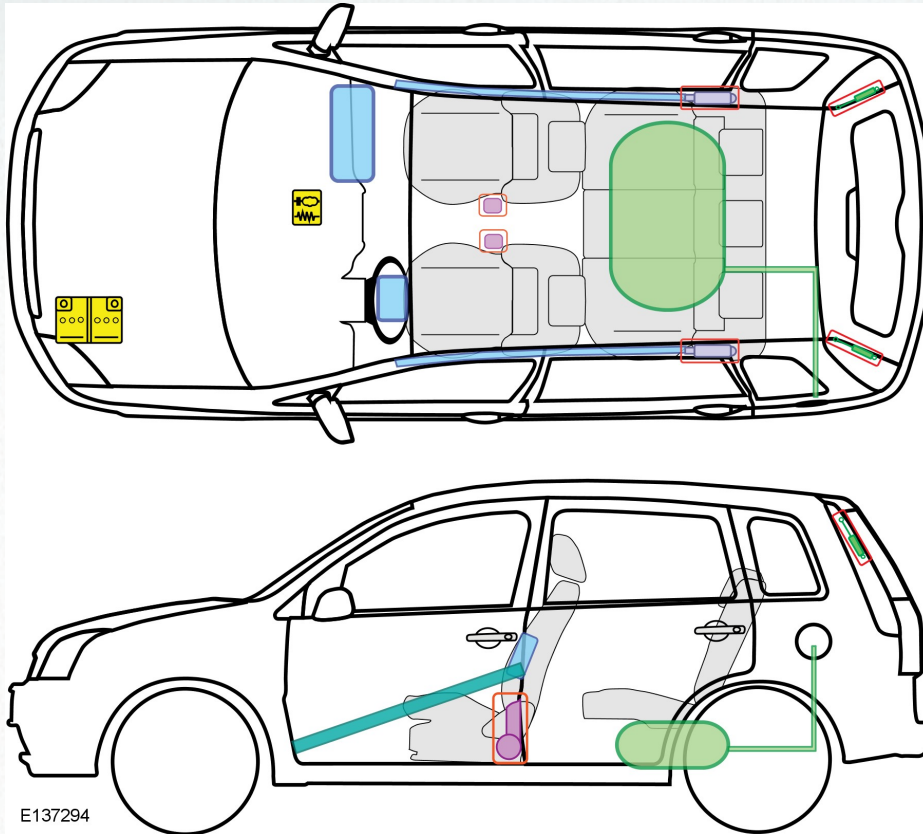

E137294

Legende

F

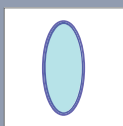

Airbag

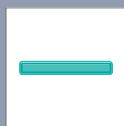

Karosseriever-
stärkung



Steuergerät



Fussgänger-
schutzsystem

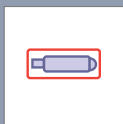

Gasgenerator



Überrollschutz-
bügel

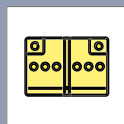

Batterie

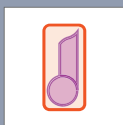

Gurtstraffer

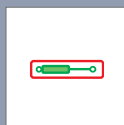

Gasdruck-
dämpfer



Kraftstofftank

(Stand : 01/2011)

FORD Galaxy

02/2006 – 05/2015

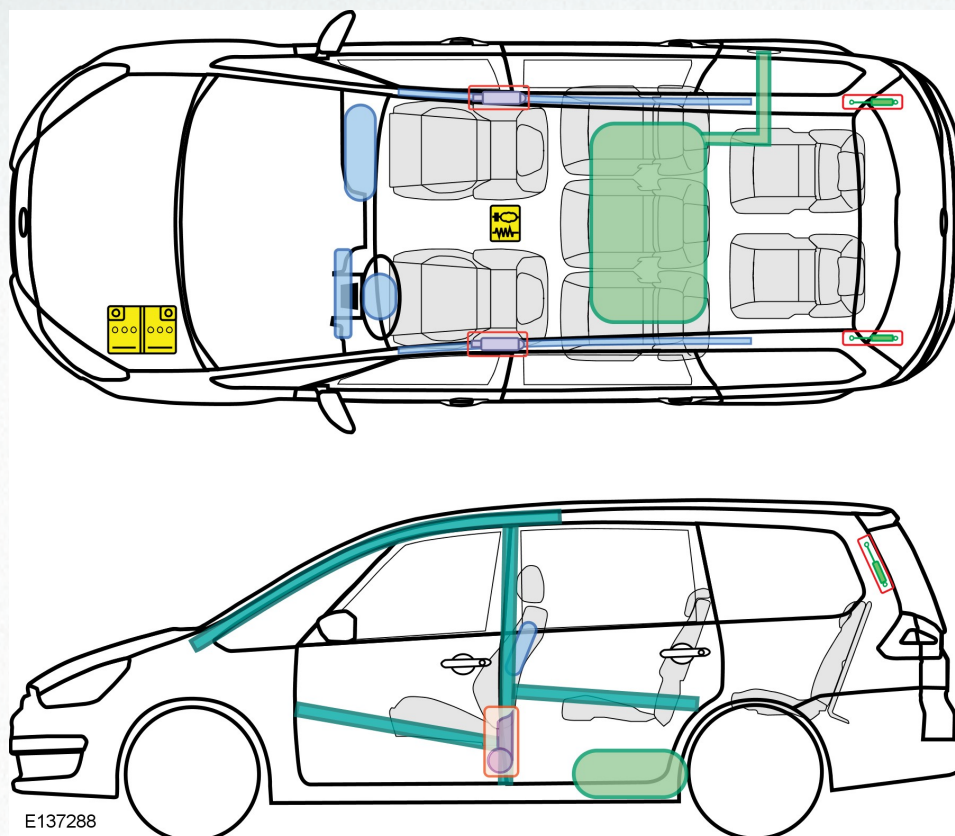

Legende

G

	Airbag		Karosserieverstärkung		Steuergerät		Fussgängerschutzsystem
	Gasgenerator		Überrollschutzbügel		Batterie		
	Gurtstraffer		Gasdruckdämpfer		Kraftstofftank		

(Stand : 06/2015)

FORD Galaxy

04/2000 – 02/2006





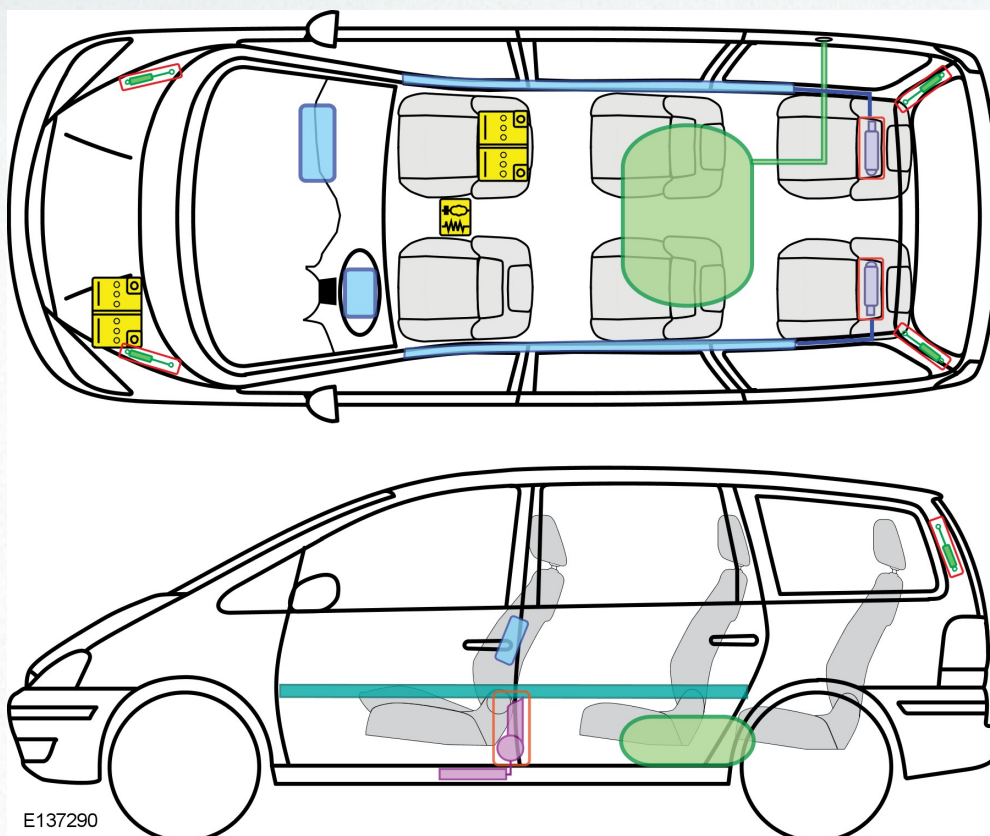



E137289

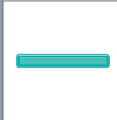

E137290

Legende

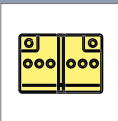
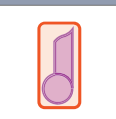
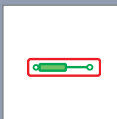
G

	Airbag		Karosseriever- stärkung		Steuergerät		Fussgänger- schutzsystem
	Gasgenerator		Überrollschut- tbügel		Batterie		
	Gurtstraffer		Gasdruck- dämpfer		Kraftstofftank		

(Stand : 01/2011)

FORD Galaxy

5-Türer LMV

05/2015 – >



E216293

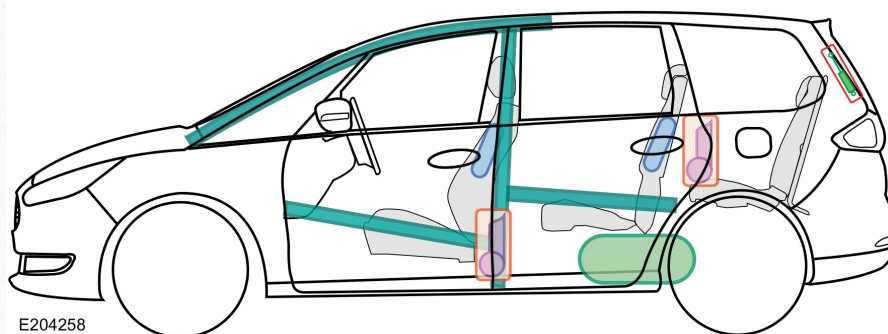
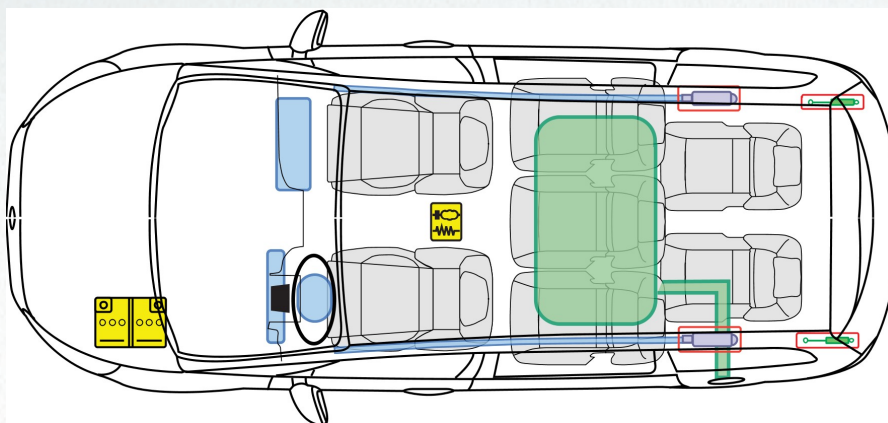

E204258

Legende

G

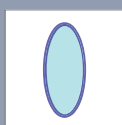

Airbag

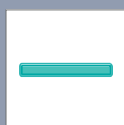

Karosseriever-
stärkung



Steuergerät



Fussgänger-
schutzsystem

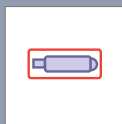

Gasgenerator



Überrollschutz-
bügel

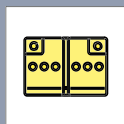

Batterie

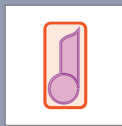

Gurtstraffer

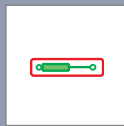

Gasdruck-
dämpfer



Kraftstofftank

(Stand : 06/2015)

FORD **GT**

12/2017 – >

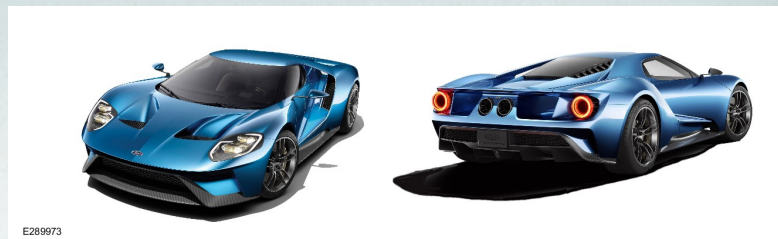

E289973

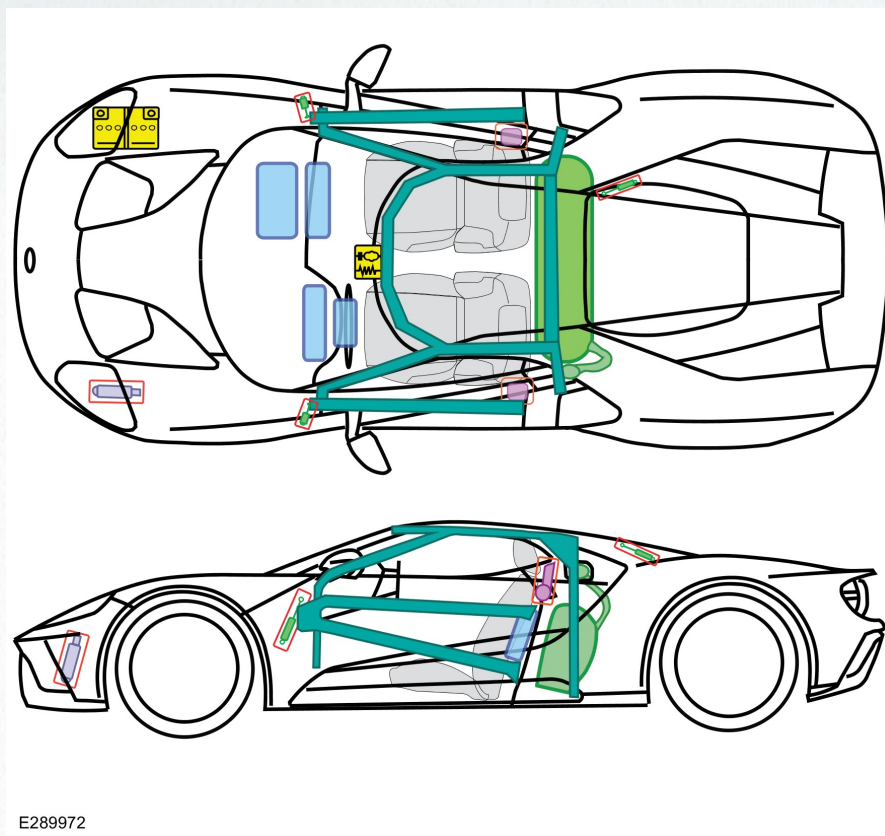

E289972

Legende

G

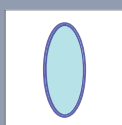

Airbag

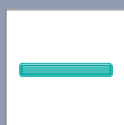

Karosseriever-
stärkung



Steuergerät



Fussgänger-
schutzsystem



Gasgenerator



Überrollschutz-
bügel

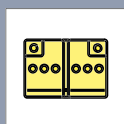

Batterie

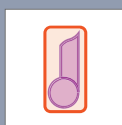

Gurtstraffer

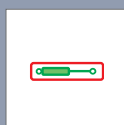

Gasdruck-
dämpfer



Kraftstofftank

(Stand : 12/2018)





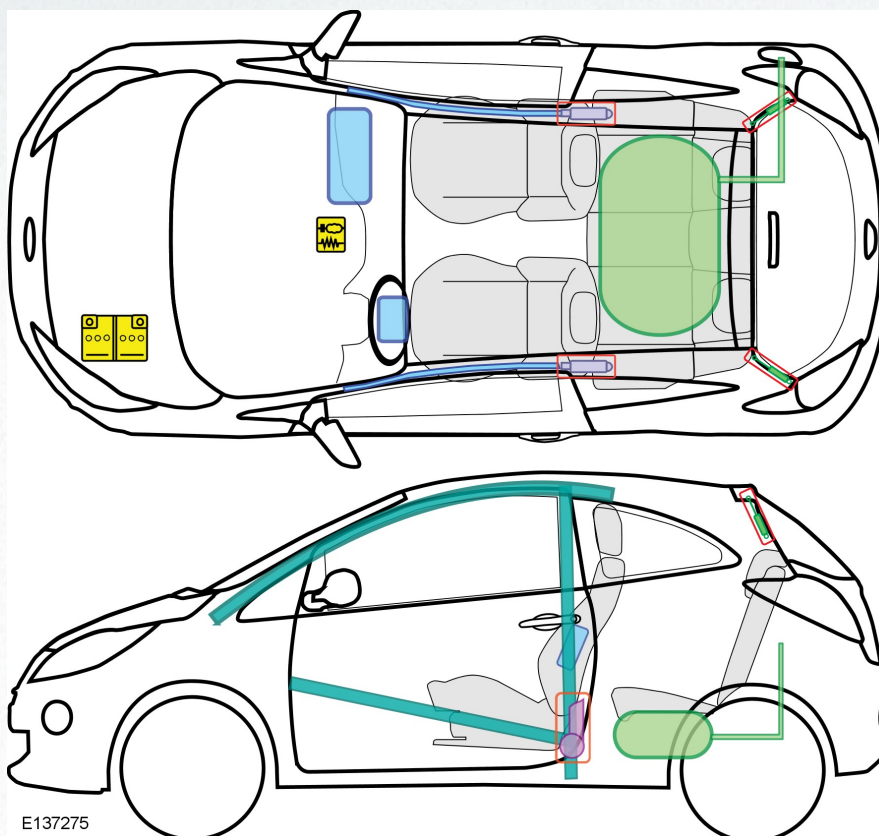

FORD KA

08/2008 – >

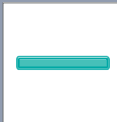

Legende

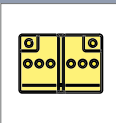
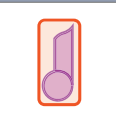
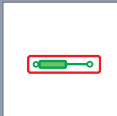
K

	Airbag		Karosseriever- stärkung		Steuergerät		Fussgänger- schutzsystem
	Gasgenerator		Überrollschutz- bügel		Batterie		
	Gurtstraffer		Gasdruck- dämpfer		Kraftstofftank		

(Stand : 01/2011)

FORD KA

09/1996 – 07/2008

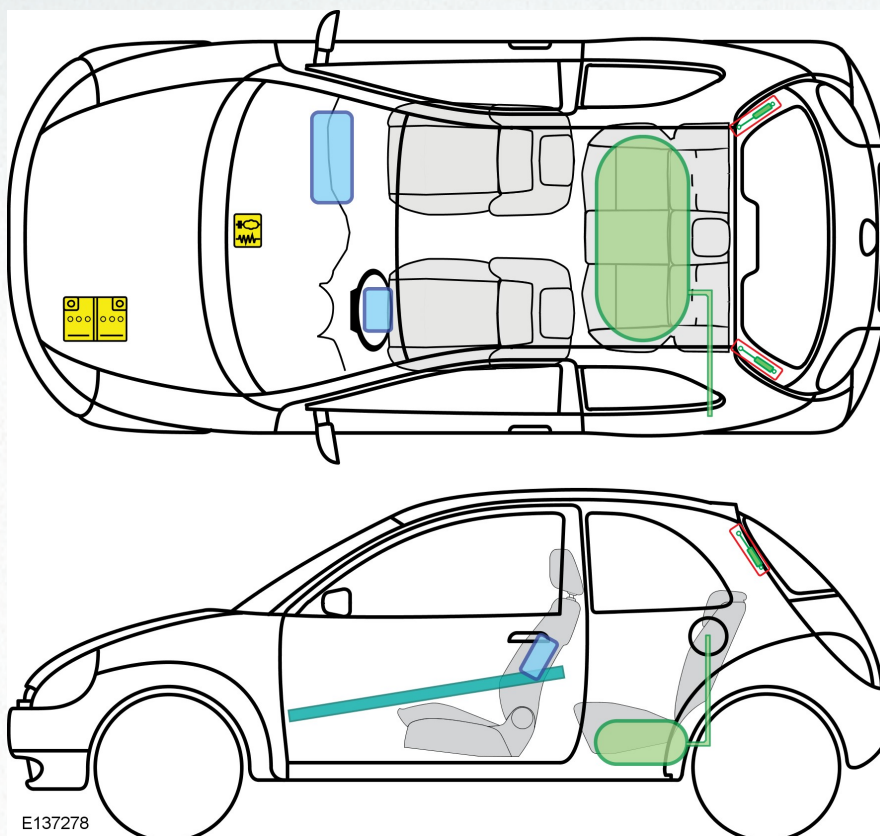

Legende

K

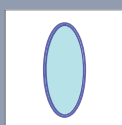

Airbag

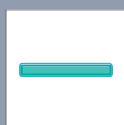

Karosseriever-
stärkung



Steuergerät



Fussgänger-
schutzsystem



Gasgenerator



Überrollschutz-
bügel

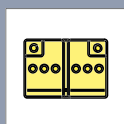

Batterie

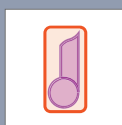

Gurtstraffer

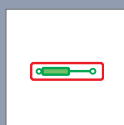

Gasdruck-
dämpfer



Kraftstofftank

(Stand : 01/2011)

FORD **Ka+**

05/2016 – >

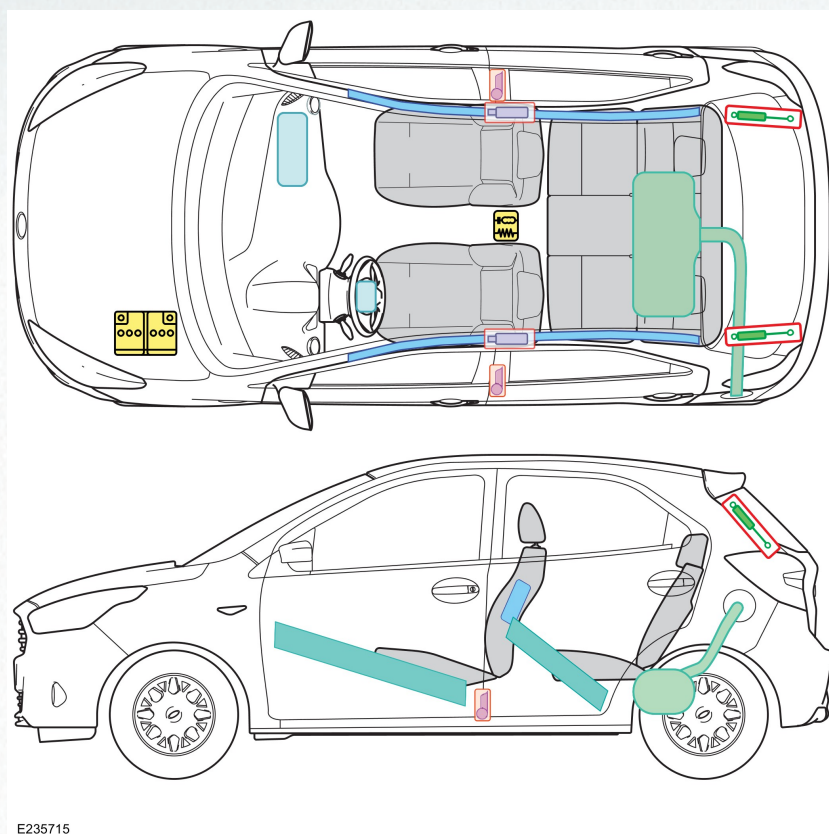

E235715

Legende

K

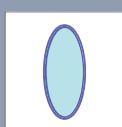

Airbag

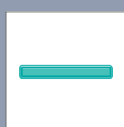

Karosseriever-
stärkung



Steuergerät



Fussgänger-
schutzsystem



Gasgenerator



Überrollschutz-
bügel

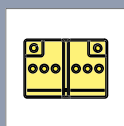

Batterie

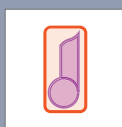

Gurtstraffer

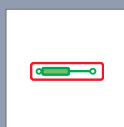

Gasdruck-
dämpfer



Kraftstofftank

(Stand : 10/2016)

FORD Kuga

02/2008 – 10/2012



E137203

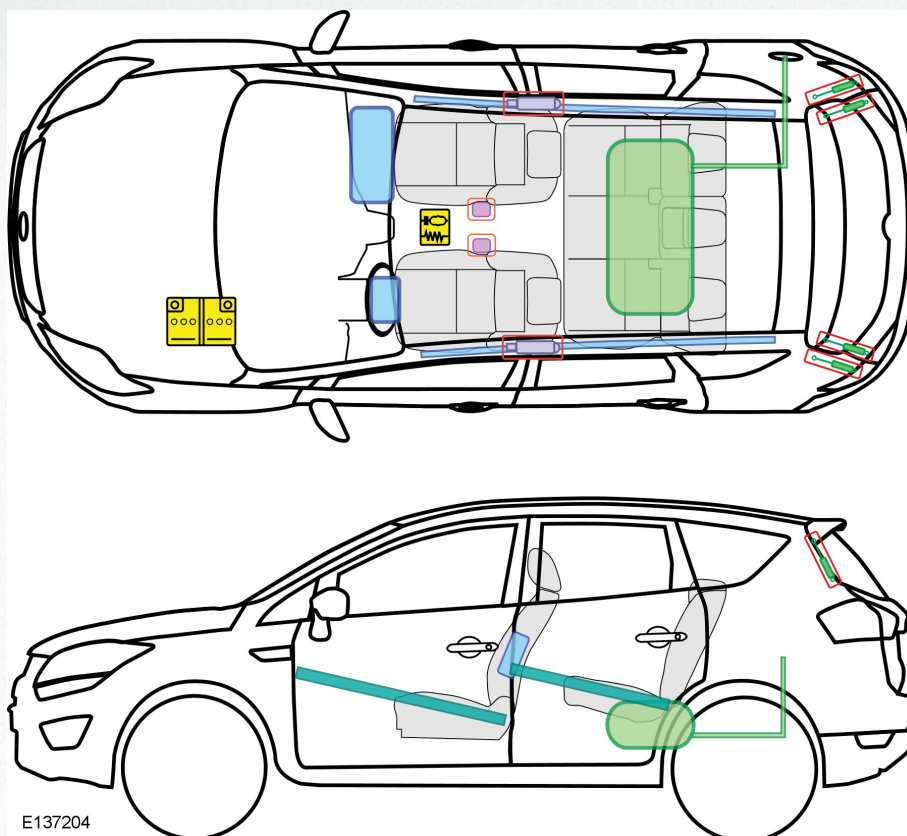

E137204

Legende

K

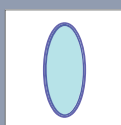

Airbag

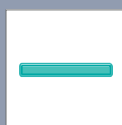

Karosseriever-
stärkung



Steuergerät



Fussgänger-
schutzsystem



Gasgenerator



Überrollschutz-
bügel

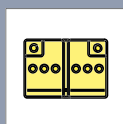

Batterie

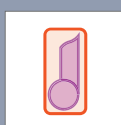

Gurtstraffer

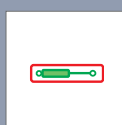

Gasdruck-
dämpfer



Kraftstofftank

(Stand : 10/2012)

FORD Kuga

10/2012 – >



E161728

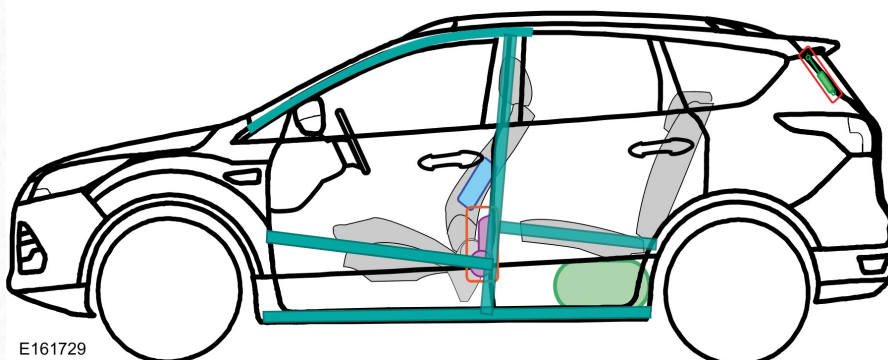
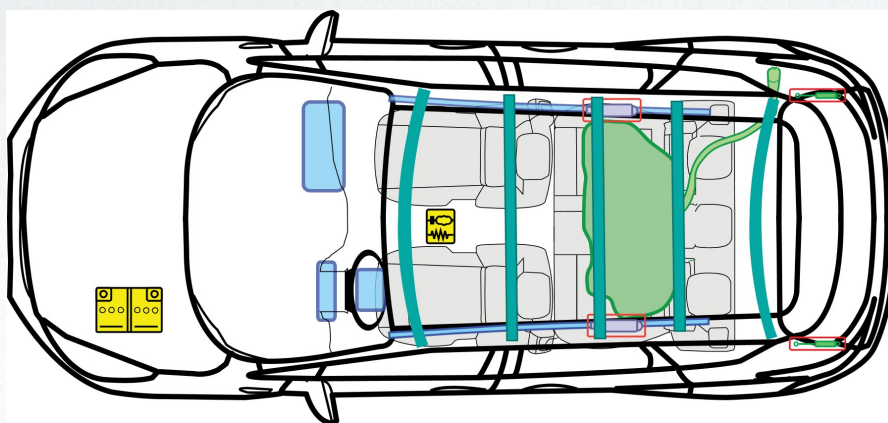

E161729

Legende

K

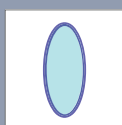

Airbag

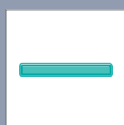

Karosseriever-
stärkung



Steuergerät



Fussgänger-
schutzsystem



Gasgenerator



Überrollschut-
zügel

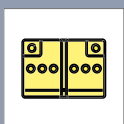

Batterie

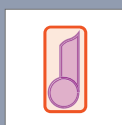

Gurtstraffer

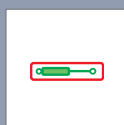

Gasdruck-
dämpfer



Kraftstofftank

(Stand : 04/2013)

FORD **Mondeo**





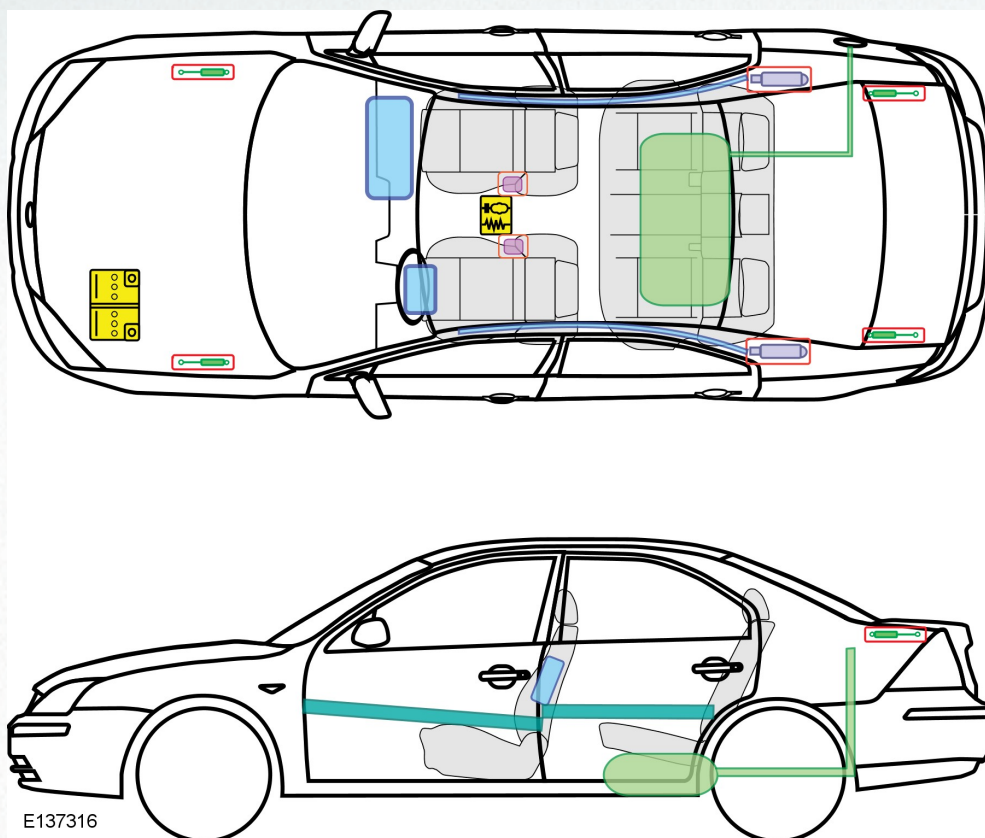

4-Türer

10/2000 – 02/2007

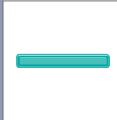

Legende

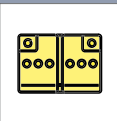
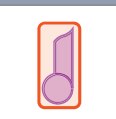
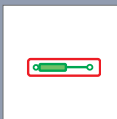
M

	Airbag		Karosseriever- stärkung		Steuergerät		Fussgänger- schutzsystem
	Gasgenerator		Überrollschut- tbügel		Batterie		
	Gurtstraffer		Gasdruck- dämpfer		Kraftstofftank		

(Stand : 01/2011)

FORD **Mondeo**

4-Türer

02/2007 – 09/2014



E137333

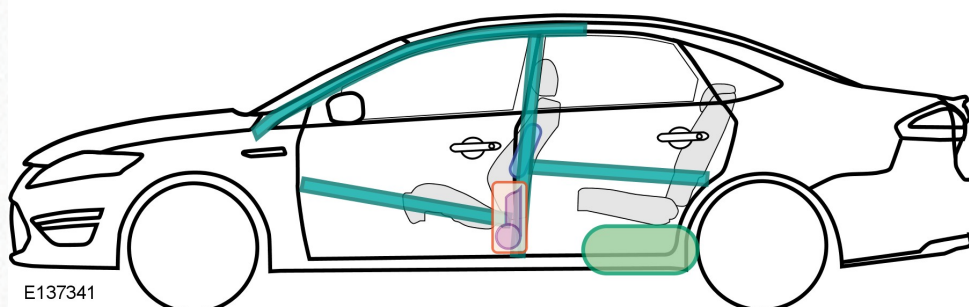
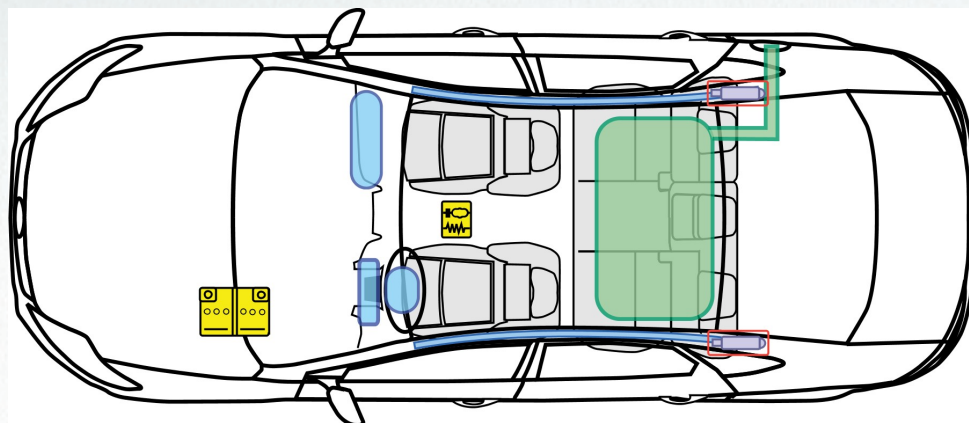

E137341

Legende

M

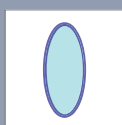

Airbag

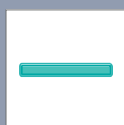

Karosseriever-
stärkung



Steuergerät



Fussgänger-
schutzsystem



Gasgenerator



Überrollschutz-
bügel

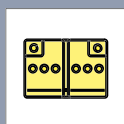

Batterie

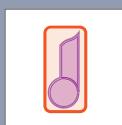

Gurtstraffer

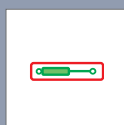

Gasdruck-
dämpfer



Kraftstofftank

(Stand : 01/2011)

FORD Mondeo - LPG

4-Türer

02/2007 – 09/2014



E137333

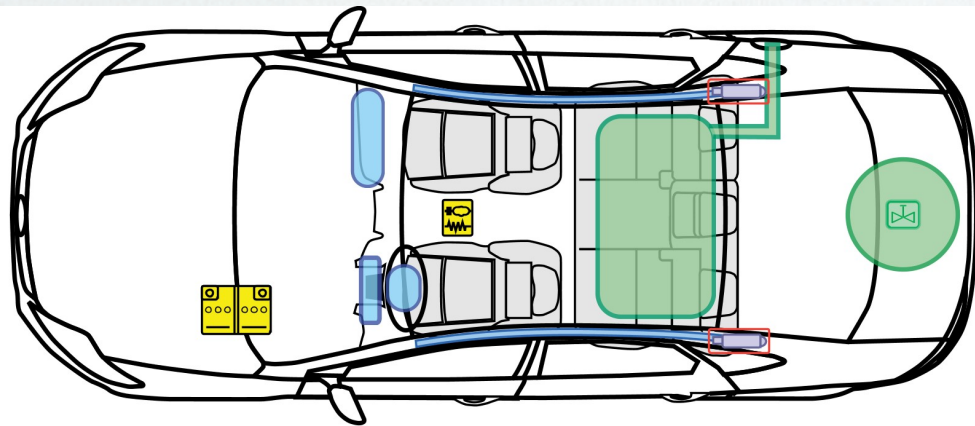



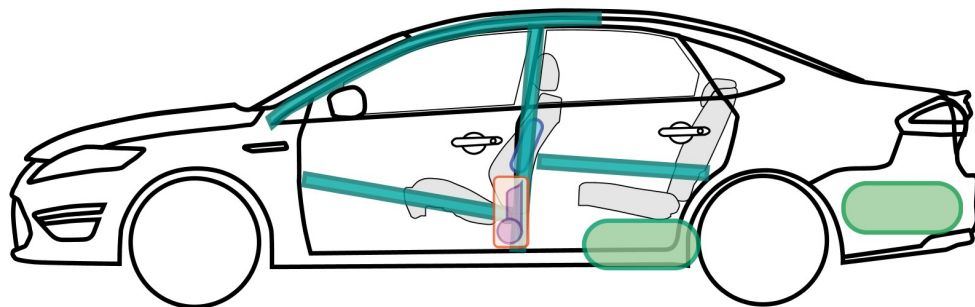



LPG

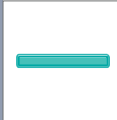

E137339

Legende

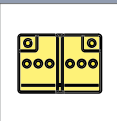
M

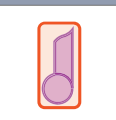
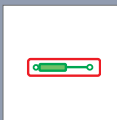
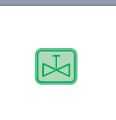
	Airbag		Karosseriever- stärkung		Steuergerät		Fussgänger- schutzsystem
	Gasgenerator		Überrollschutz- bügel		Batterie		Gastank
	Gurtstraffer		Gasdruck- dämpfer		Kraftstofftank		Sicherheits- ventil

(Stand : 02/2015)

FORD **Mondeo**

5-Türer

10/2000 – 02/2007

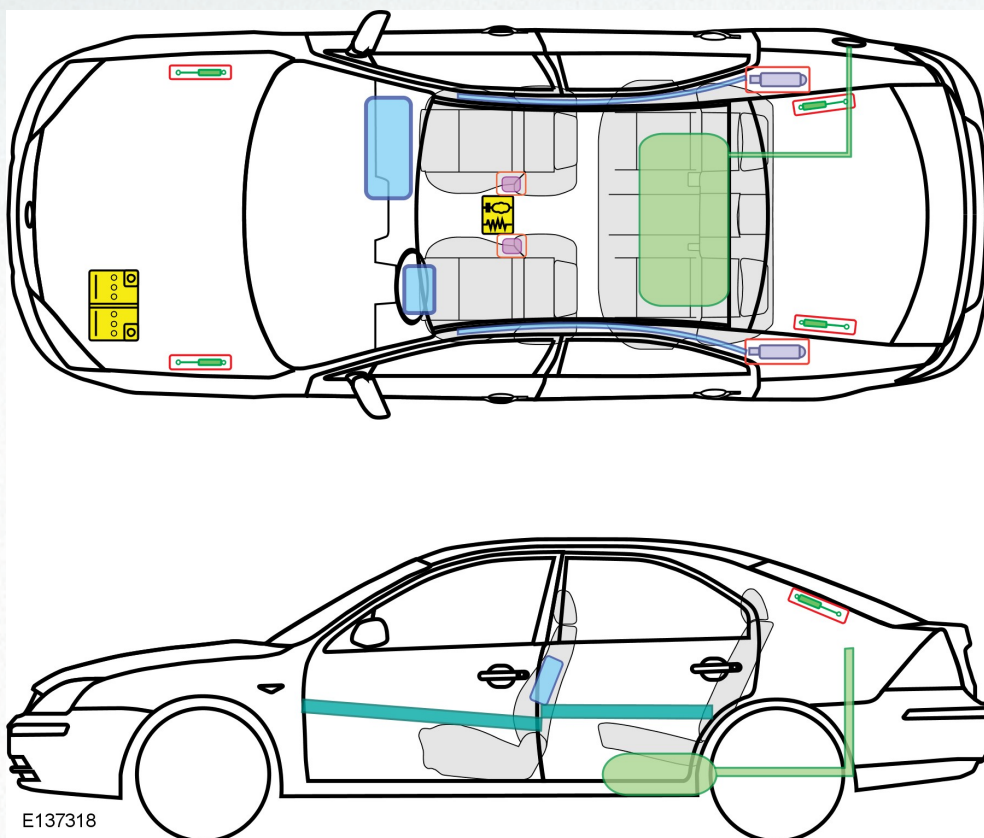

E137318

Legende

M

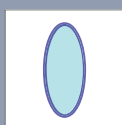

Airbag

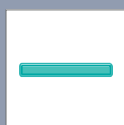

Karosseriever-
stärkung



Steuergerät



Fussgänger-
schutzsystem



Gasgenerator



Überrollschut-
tbügel

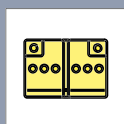

Batterie

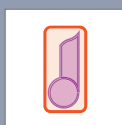

Gurtstraffer

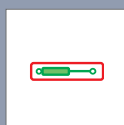

Gasdruck-
dämpfer



Kraftstofftank

(Stand : 01/2011)

FORD Mondeo

5-Türer

02/2007 – 09/2014



E137333

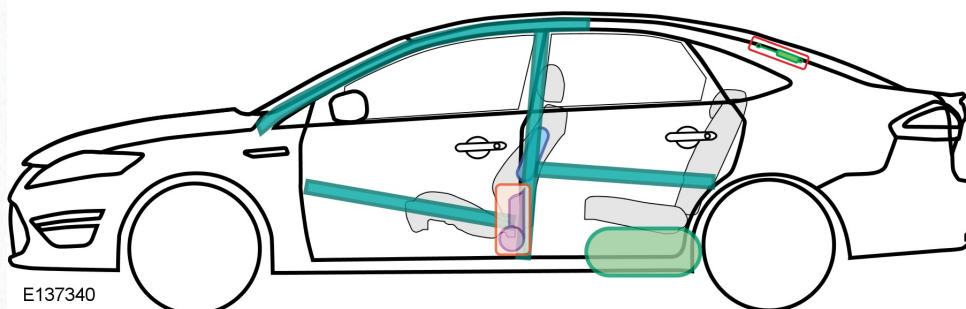
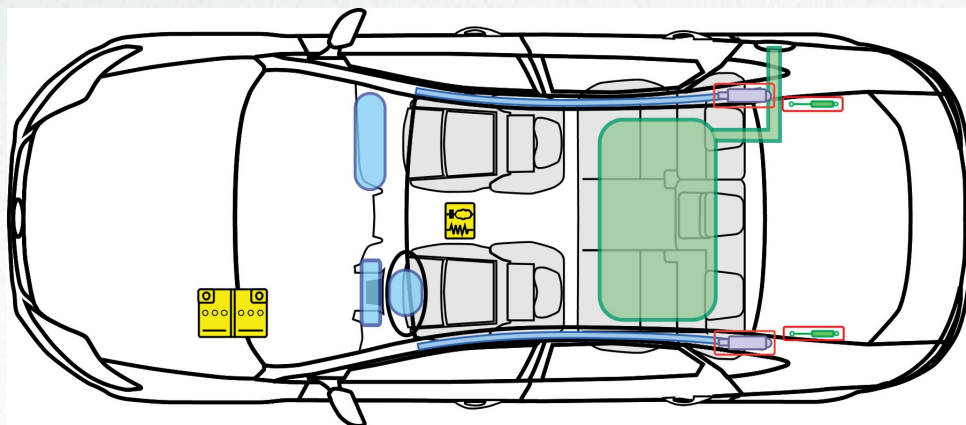

E137340

Legende

M

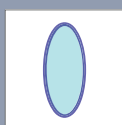

Airbag

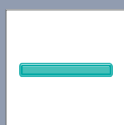

Karosseriever-
stärkung



Steuergerät



Fussgänger-
schutzsystem



Gasgenerator



Überrollschutz-
bügel

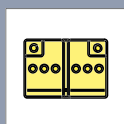

Batterie

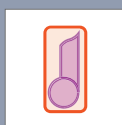

Gurtstraffer

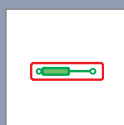

Gasdruck-
dämpfer



Kraftstofftank

(Stand : 01/2011)

FORD **Mondeo**

5-Türer

09/2014 – >



E199377

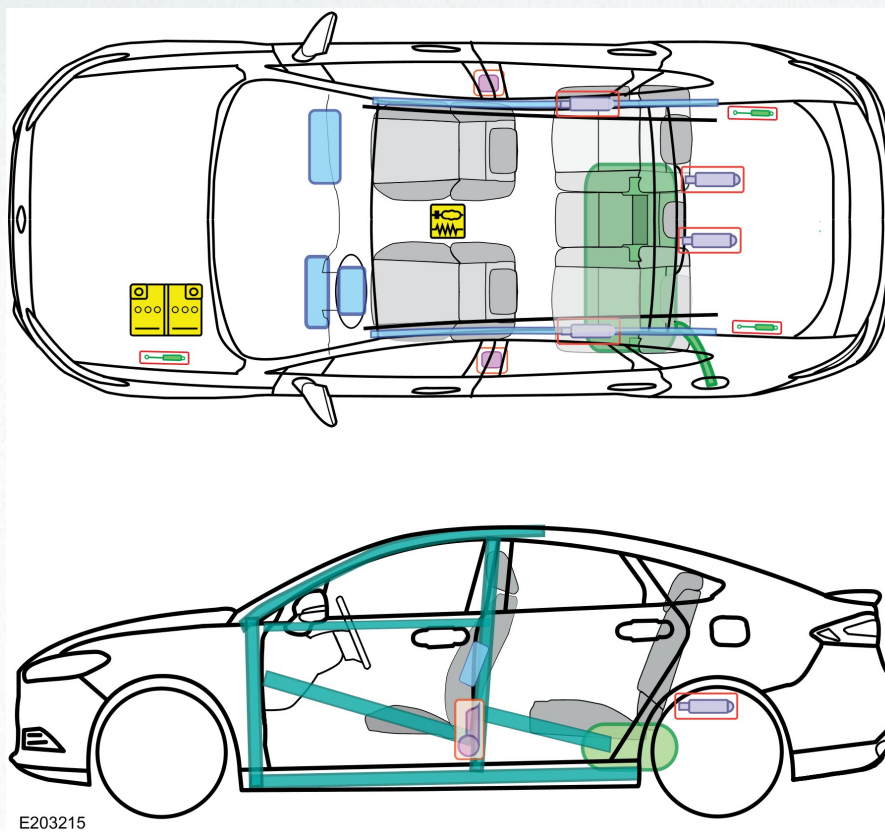

E203215

Legende

M

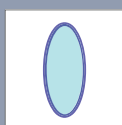

Airbag

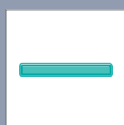

Karosseriever-
stärkung



Steuergerät



Fussgänger-
schutzsystem



Gasgenerator



Überrollschutz-
bügel

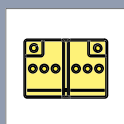

Batterie

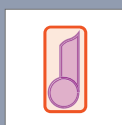

Gurtstraffer

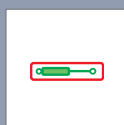

Gasdruck-
dämpfer



Kraftstofftank

(Stand : 05/2015)

FORD Mondeo - LPG

5-Türer

02/2007 – 09/2014



E137333

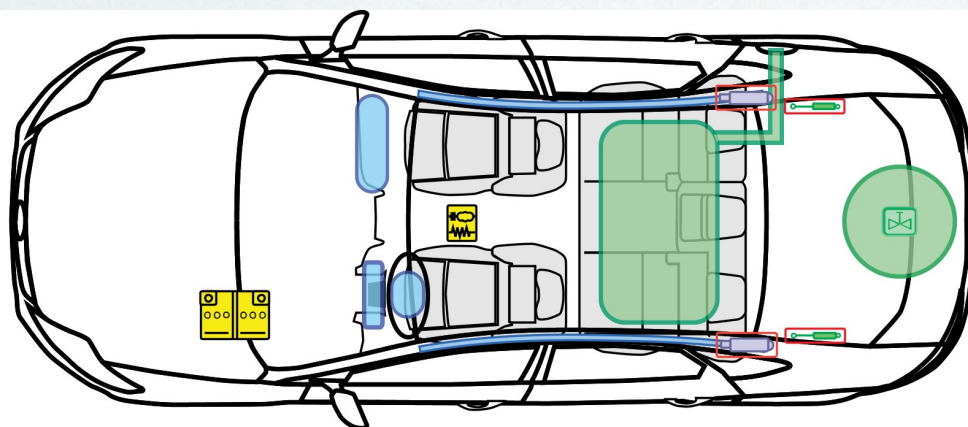



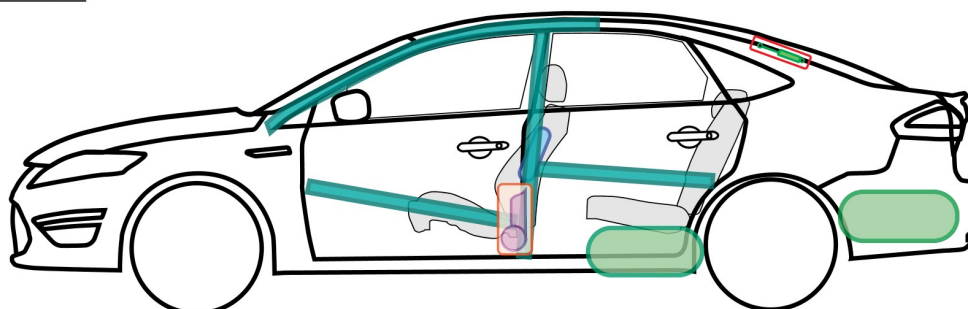





LPG

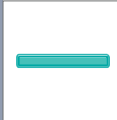

E137337

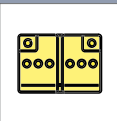
Legende

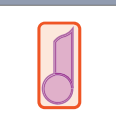
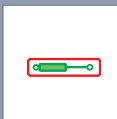
M

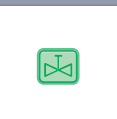
	Airbag		Karosseriever- stärkung		Steuergerät		Fussgänger- schutzsystem
	Gasgenerator		Überrollschutz- bügel		Batterie		Gastank
	Gurtstraffer		Gasdruck- dämpfer		Kraftstofftank		Sicherheits- ventil

(Stand : 02/2015)

FORD **Mondeo**

Turnier

10/2000 – 02/2007

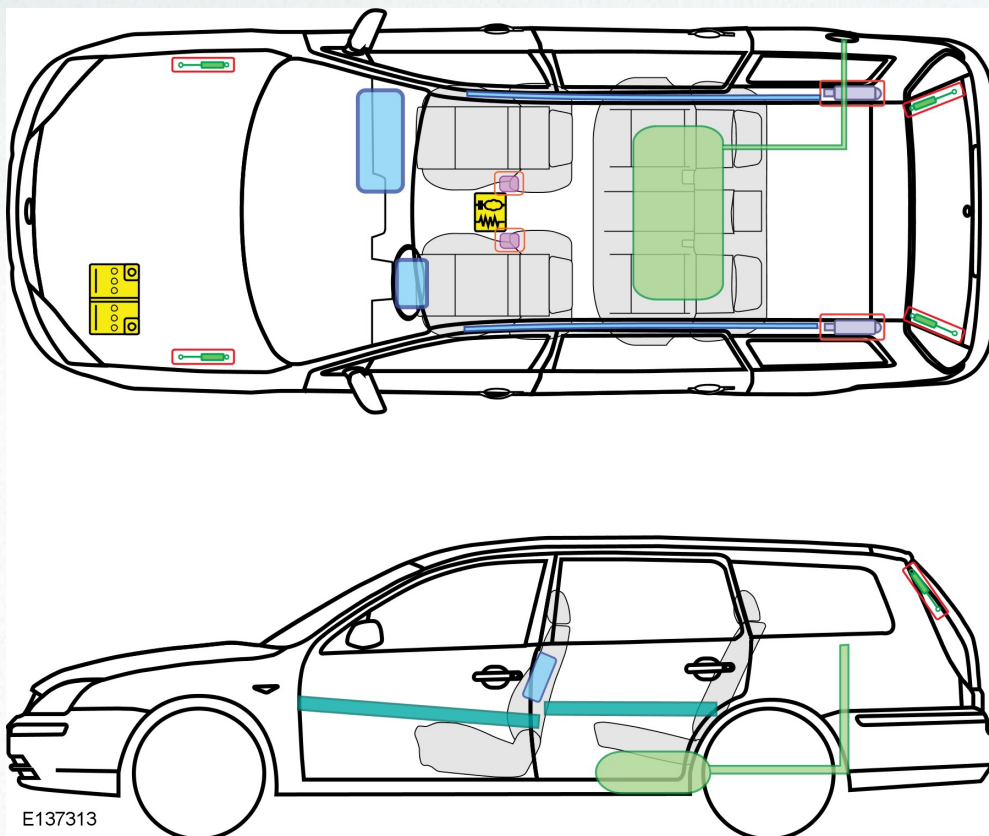

E137313

Legende

M

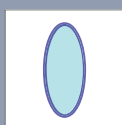

Airbag

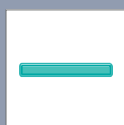

Karosseriever-
stärkung



Steuergerät



Fussgänger-
schutzsystem

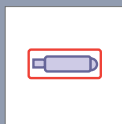

Gasgenerator



Überrollschut-
bügel

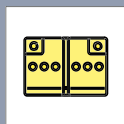

Batterie

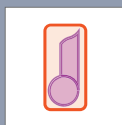

Gurtstraffer

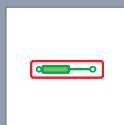

Gasdruck-
dämpfer

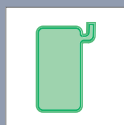

Kraftstofftank

(Stand : 01/2011)

FORD **Mondeo**

Turnier

02/2007 – 09/2014



E137327

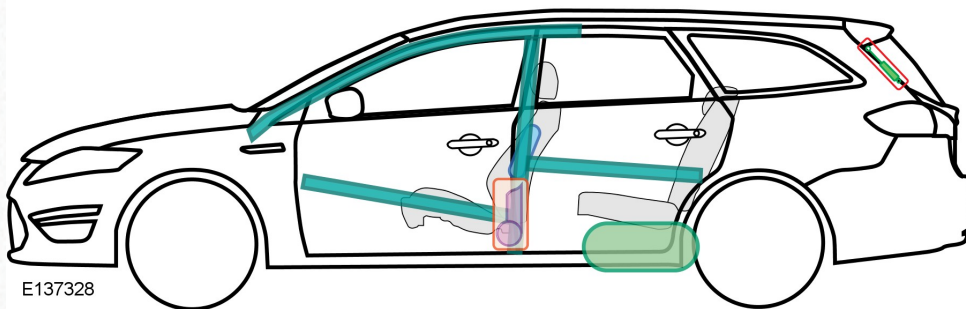
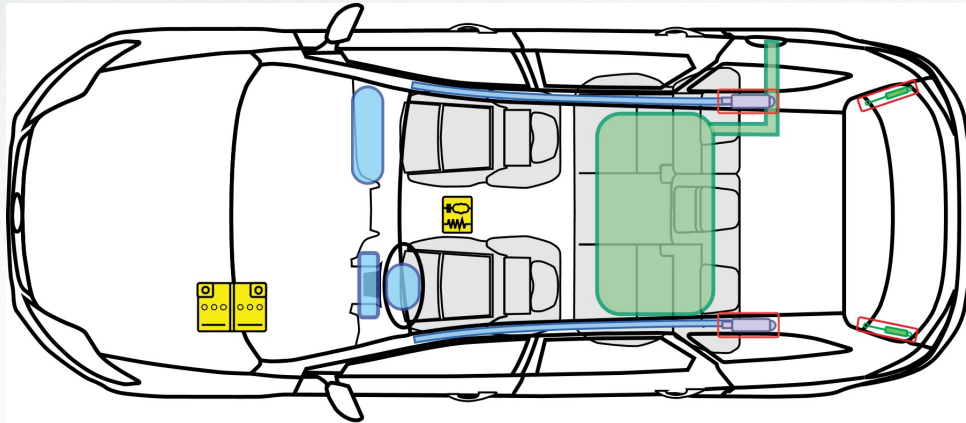

E137328

Legende

M

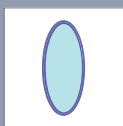

Airbag

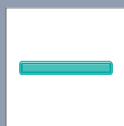

Karosseriever-
stärkung



Steuergerät



Fussgänger-
schutzsystem

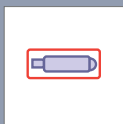

Gasgenerator



Überrollschutz-
bügel

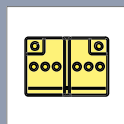

Batterie

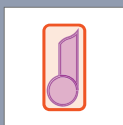

Gurtstraffer

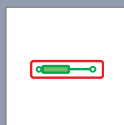

Gasdruck-
dämpfer



Kraftstofftank

(Stand : 01/2011)

FORD **Mondeo**

Turnier

09/2014 – >



E203689

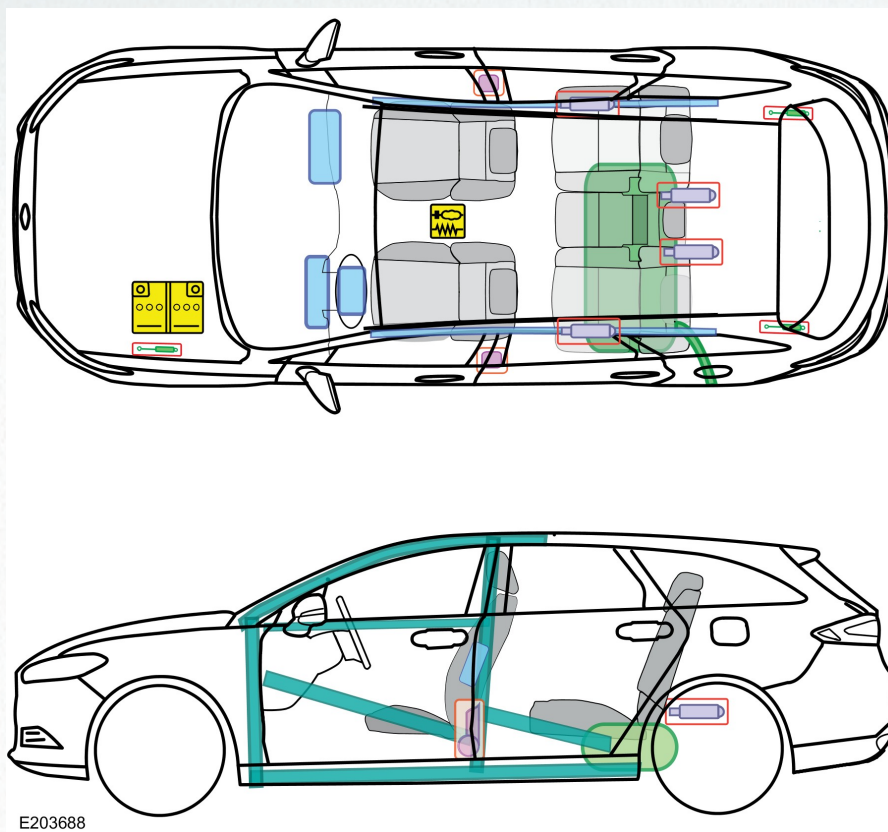

E203688

Legende

M

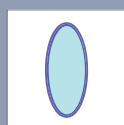

Airbag

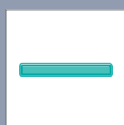

Karosseriever-
stärkung



Steuergerät



Fussgänger-
schutzsystem

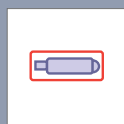

Gasgenerator



Überrollschutz-
bügel

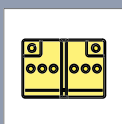

Batterie

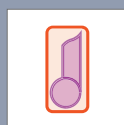

Gurtstraffer

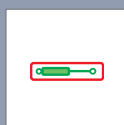

Gasdruck-
dämpfer



Kraftstofftank

(Stand : 01/2015)

FORD Mondeo - LPG

Turnier

02/2007 – 09/2014

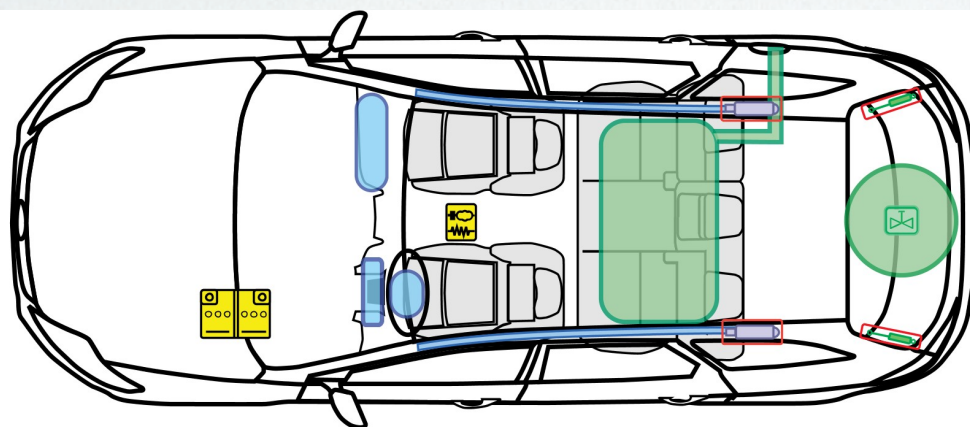



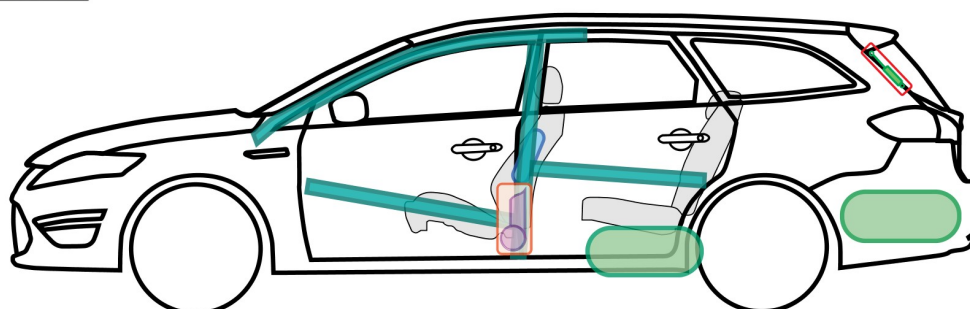





LPG

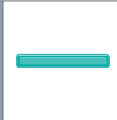

E137334

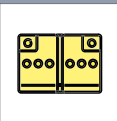
Legende

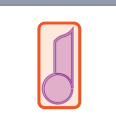
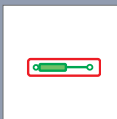
M

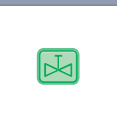
	Airbag		Karosseriever- stärkung		Steuergerät		Fussgänger- schutzsystem
	Gasgenerator		Überrollschutz- bügel		Batterie		Gastank
	Gurtstraffer		Gasdruck- dämpfer		Kraftstofftank		Sicherheits- ventil

(Stand : 02/2015)

FORD Mondeo "Hybrid" - HEV

4-Türer

10/2014 – >



E199377

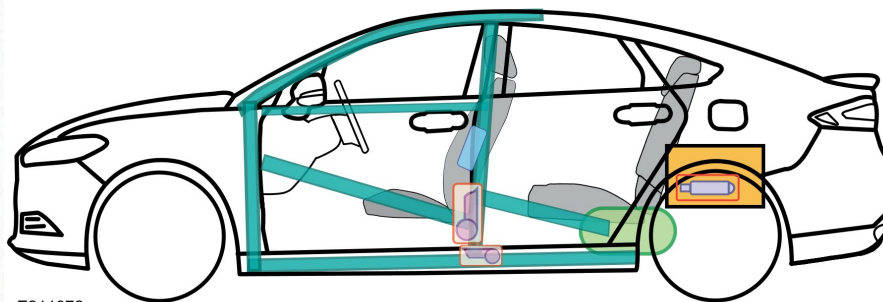
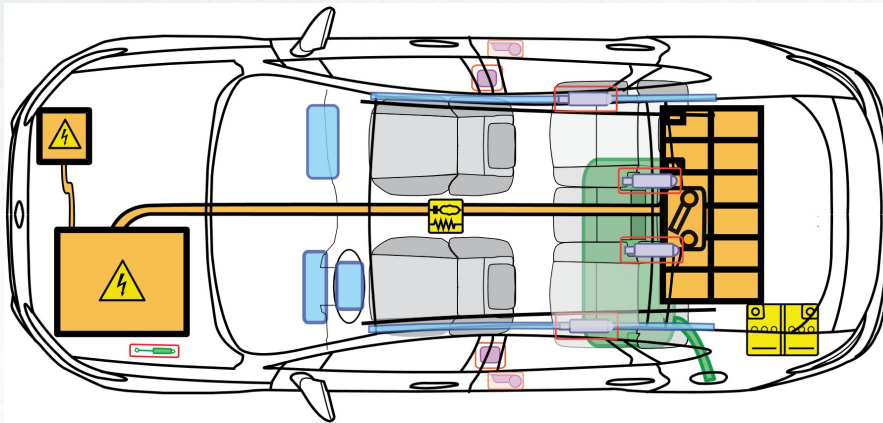

E211972

Legende

M

	Airbag		Karosseriever- stärkung		Steuergerät		Hochvoltbat- terie		Fussgänger- schutzsystem
	Gasgenerator		Überrollschutz- bügel		Batterie		Hochvolt- leitung/ komponenten		
	Gurtstraffer		Gasdruck- dämpfer		Kraftstofftank		Hochvolttren- nstelle		

(Stand : 02/2017)

HOCHVOLTSYSTEM-Deaktivierung

Vorwort

ES IST IMMER DAVON AUSZUGEHEN; DASS DAS HOCHVOLTSYSTEM DES FAHRZEUGS IN BETRIEB IST!

VOR ARBEITEN AM FAHRZEUG SICHERSTELLEN, DASS EXTERNE STROMVERSORGUNGEN GETRENNT SIND (z. B. Ladegeräte, Elektrowerkzeuge). Das Missachten dieser Anweisung kann zu schweren Verletzungen oder zum Tod führen.

ELEKTROFAHRZEUG-IDENTIFIZIERUNGSNUMMER

Identifizierung anhand der Fahrzeug-Identifizierungsnummer (VIN)

Die 10. Stelle der Fahrzeug-Identifizierungsnummer (VIN) identifiziert Fahrzeuge mit Hybrid-Antrieb.

VIN-STELLEN 1, 2, 3, 4, 5, 6, 7, 8, 9 und 10	FAHRZ WIRD
WF0DXXWPC	Mondeo Hybrid
BEISPIEL-VIN	
WF0DXXWPCEB12345	

Identifizierung anhand von Fahrzeugmerkmalen



1. HYBRID-Aufkleber an beiden Türen vorn und Heckklappe

Identifizierung anhand von Merkmalen des Motorraums

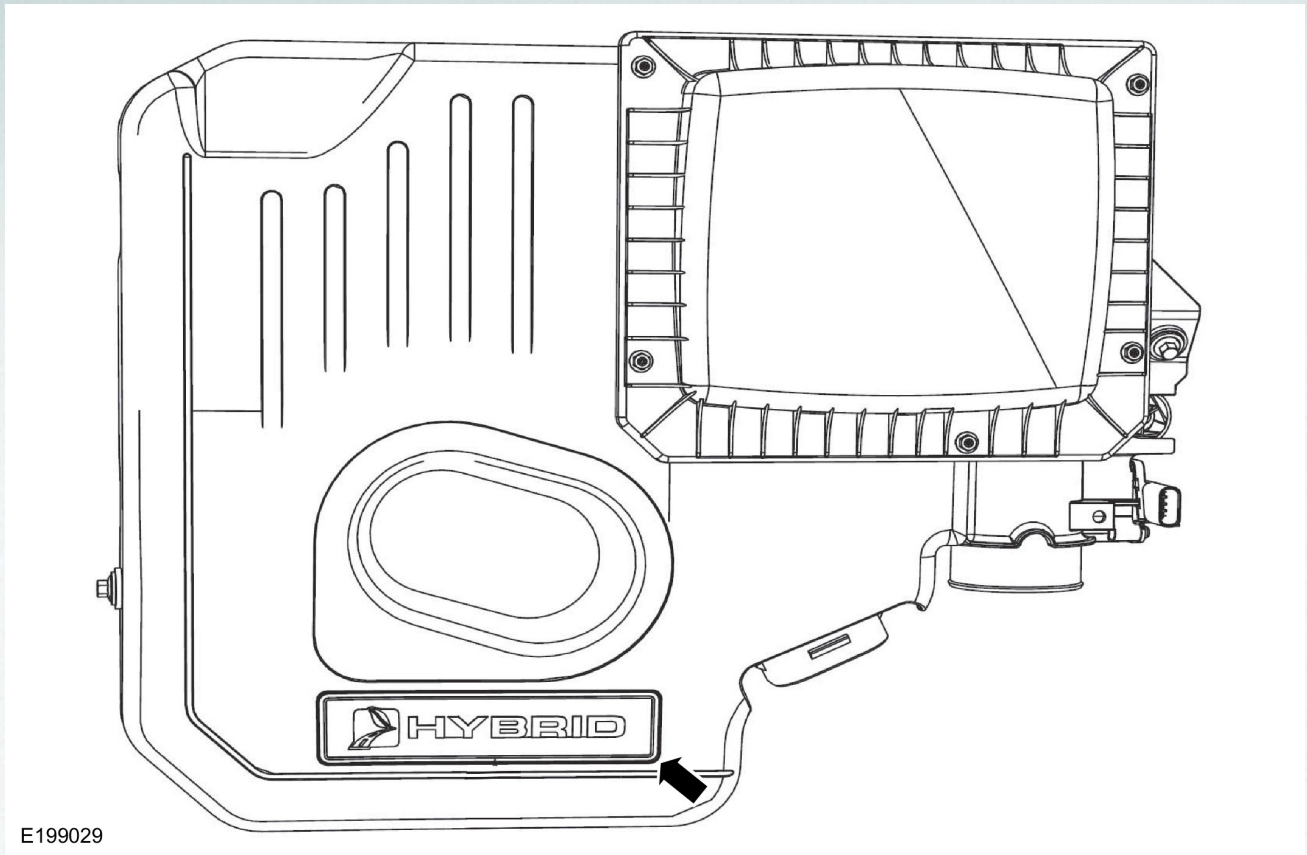

1. Die Hybrid-Version des Mondeo hat eine unverwechselbare Motorabdeckung mit einem erhabenen "HYBRID"-Symbol.

FUNKTIONEN ZUM TRENNEN DER HOCHVOLTVERSORUNG

WARNUNGEN:

- ⚠** Durch Abziehen des Hochvolt-Servicesteckers wird die Hochspannung vom Fahrzeug getrennt. Die Batteriepackung steht weiterhin unter Spannung und bleibt gefährlich. Das Gehäuse der Hochvoltbatterie nicht schneiden. Die Batterien oder das Gehäuse in keiner Form durchdringen. Nach Möglichkeit für Isolierung sorgen und die Berührung mit Hochvoltbauteilen des Fahrzeugs meiden.
- ⚠** Bei Elektrofahrzeugen, die durch einen Unfall beschädigt wurden, besteht Gefahr durch Hochspannungsstromschlag, weil unter Umständen die Hochvolt-Sicherheitssysteme defekt sind. Vorsicht anwenden und geeignete persönliche Schutzausrüstung tragen. Alle metallhaltigen Schmuckgegenstände wie beispielsweise Uhren und Ringe abnehmen. Das Missachten dieser Anweisung kann zu schweren Verletzungen oder zum Tod führen.

Zündung AUS — Wenn sich die Zündung in Stellung AUS befindet (und das Fahrzeug nicht geladen wird), ist das Hochvoltssystem deaktiviert.

Hochvolt-Servicestecker — Bei abgezogenem Hochvolt-Servicestecker ist das Hochvolt-System deaktiviert.

Deaktivierung

Methode 1

BEACHTEN: Die Zündung muss unbedingt ausgeschaltet werden, bevor der Anschluss der 12-V-Batterie getrennt wird. Bei Zündung in Stellung EIN besteht die Möglichkeit, dass das HV-System möglicherweise noch aktiv ist.

Falls kein Zugang zur Batterie möglich ist, mit Methode 2 fortfahren.

1. Das Hochvolt-System auf Strom prüfen.



2. Wenn das Hochvoltssystem aktiv ist, den MOTORSTARTKNOPF einmal drücken.



E199171

3. Abdeckung ausbauen, um Zugang zur 12-V-Batterie zu erhalten.

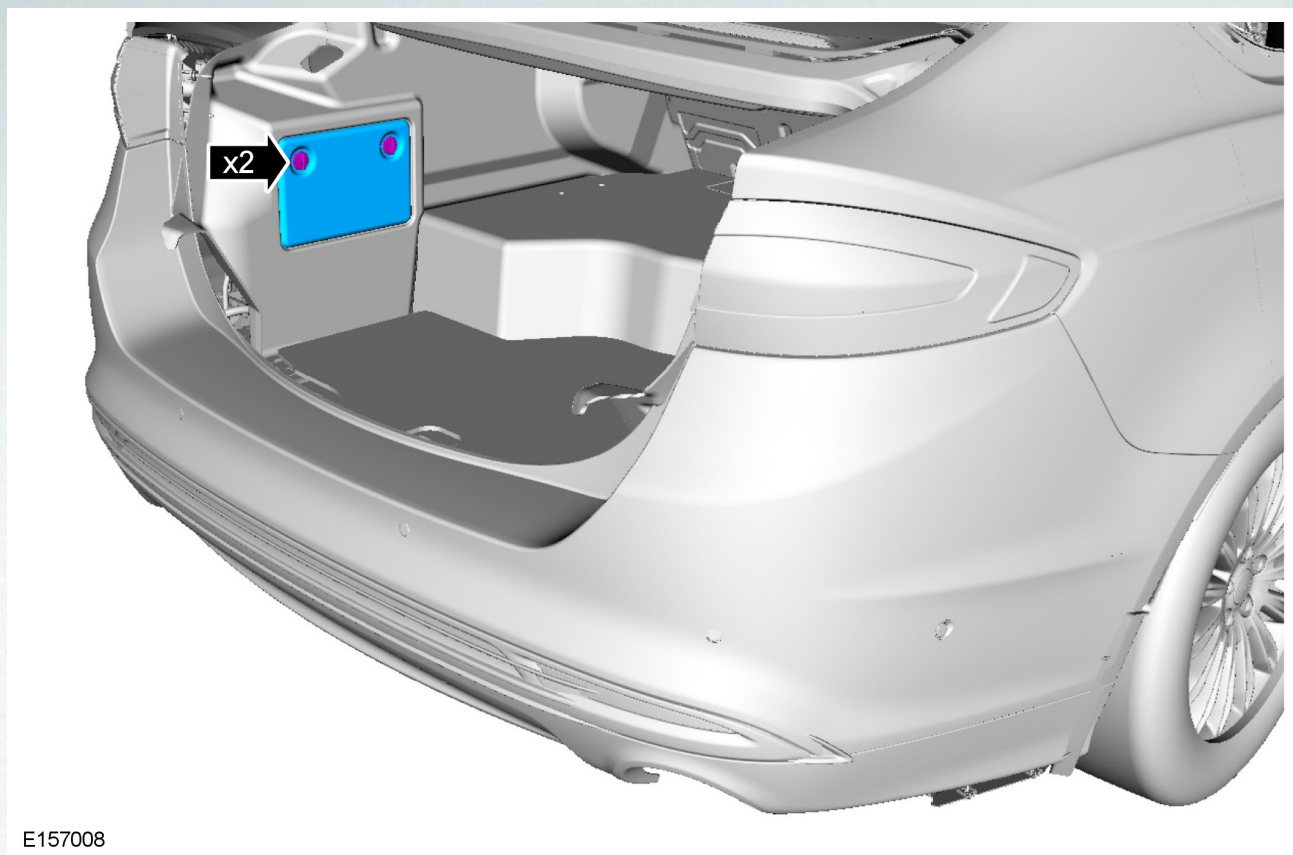

E157008

4. Das Kabel der 12-V-Batterie abnehmen.

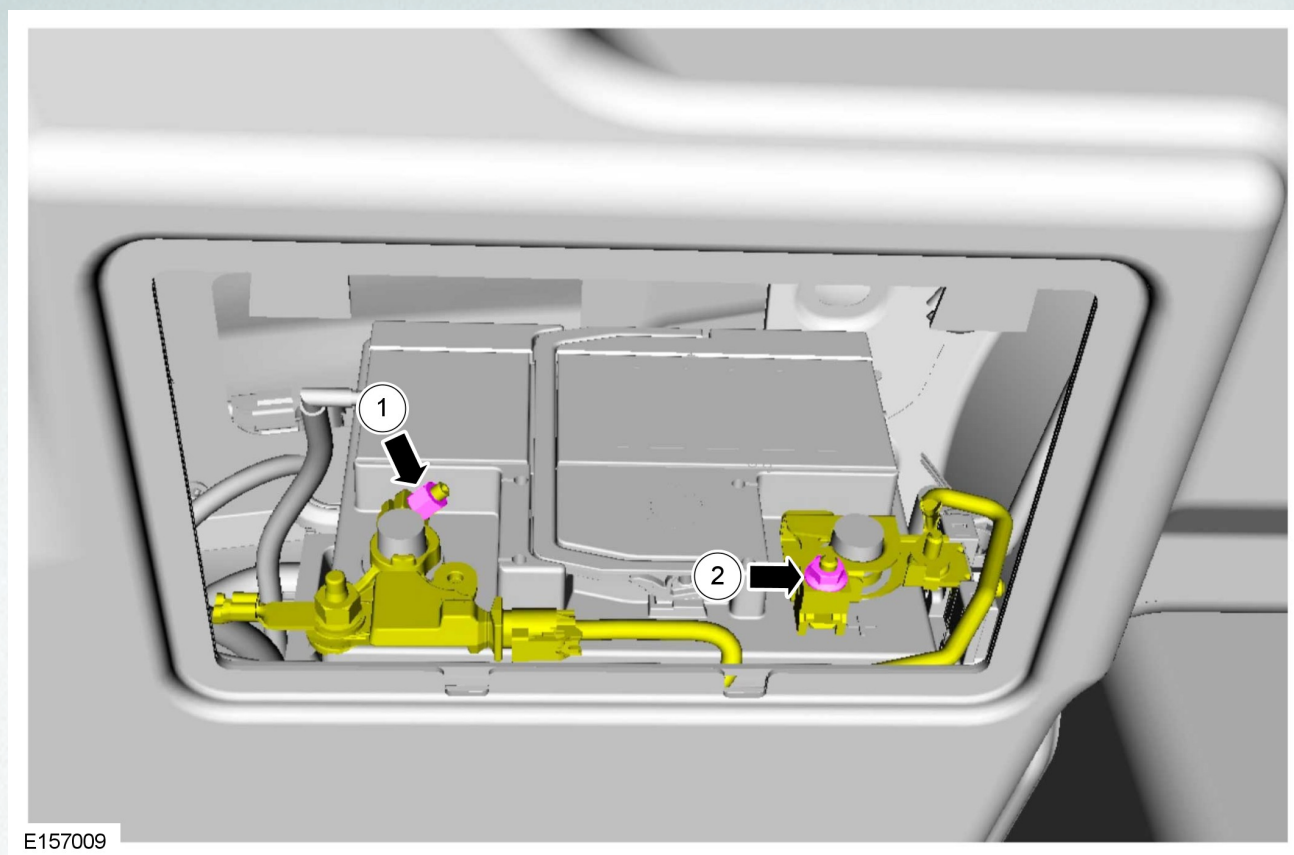

E157009

Methode 2

BEACHTEN: Um Zugang zum Hochvolt-Servicestecker zu erhalten, muss die hintere 60 % Rücksitzlehne heruntergeklappt werden.

1. Den Sitzlehnen-Entriegelungshebel oben auf der Sitzlehne ermitteln.

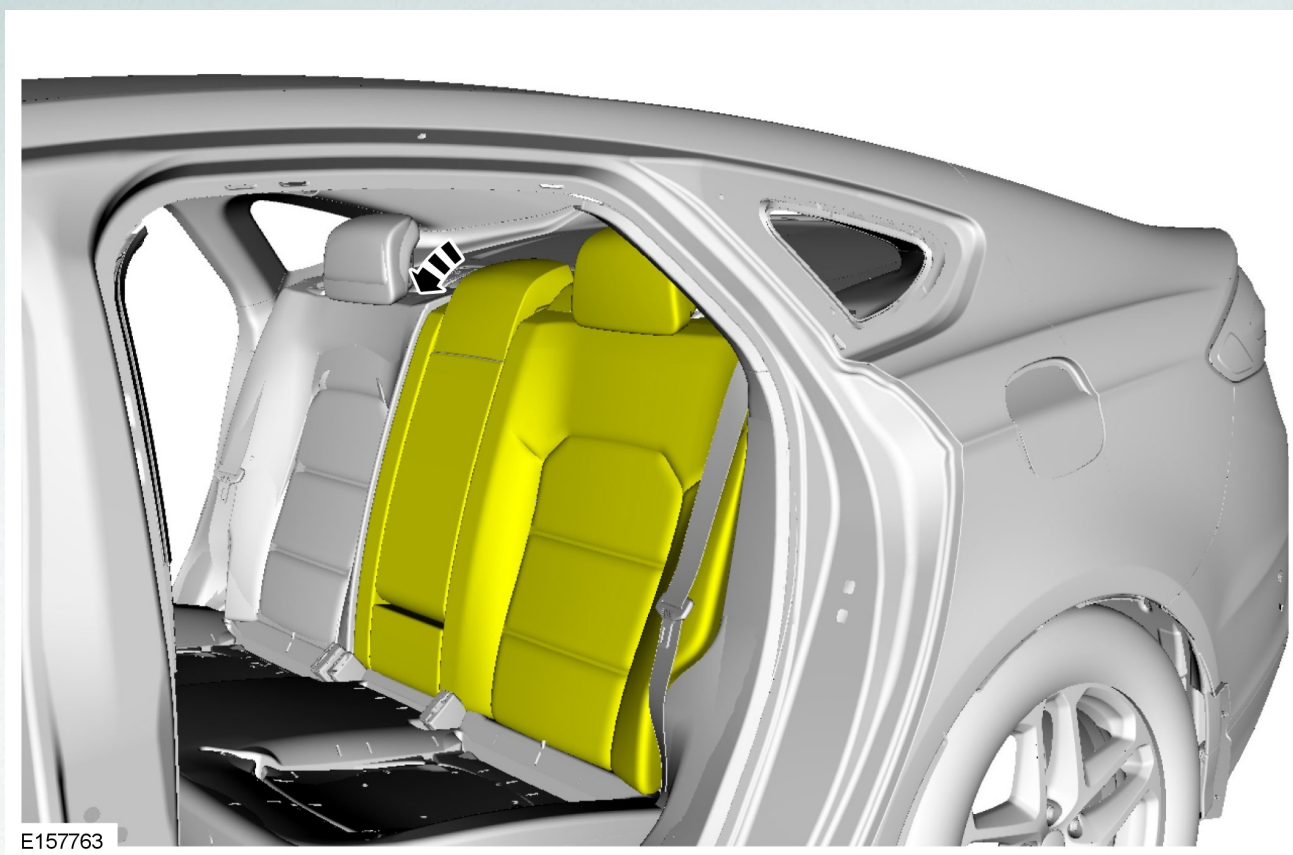

2. Abdeckung abnehmen, um Zugang zum oberen Batterieservicestecker zu erhalten.

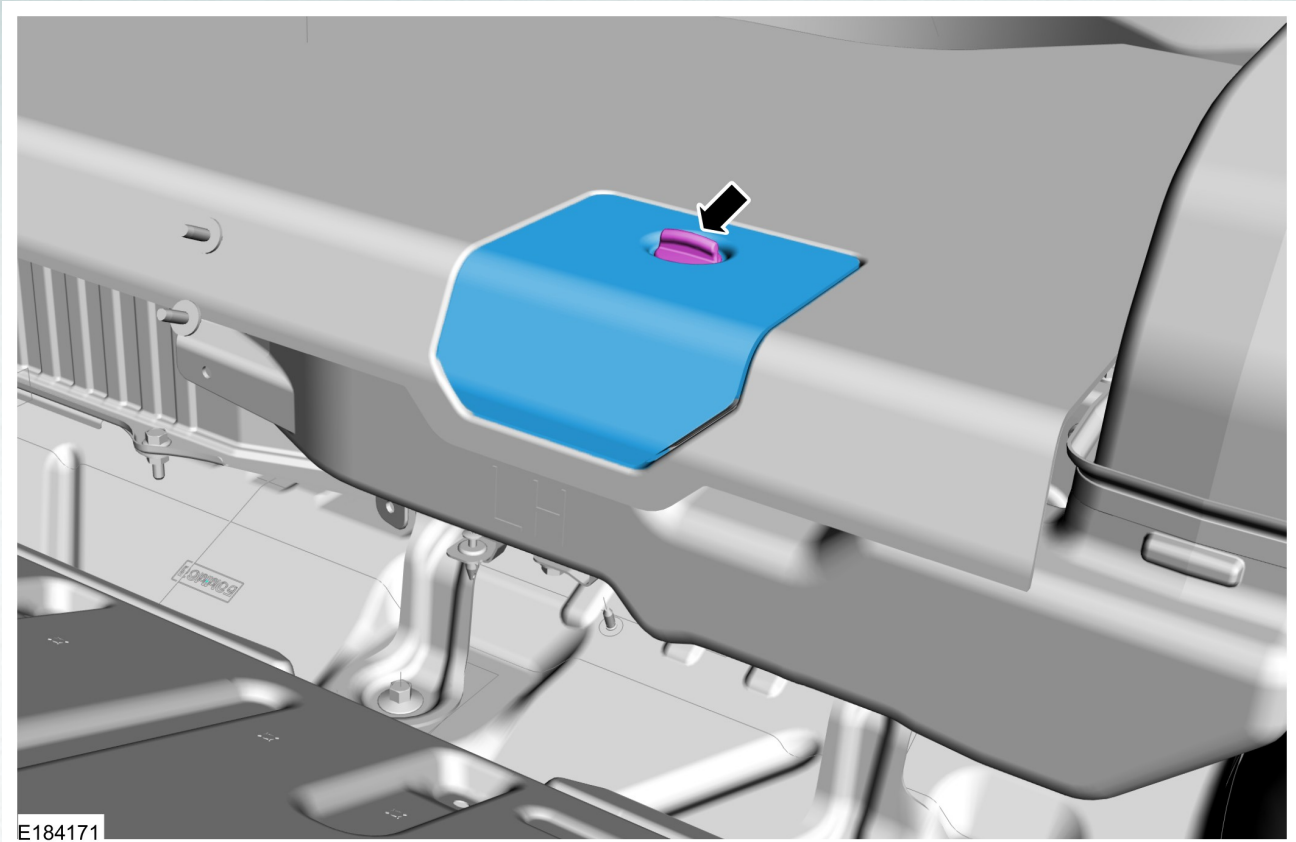

E184171

3. Sofern vorhanden.

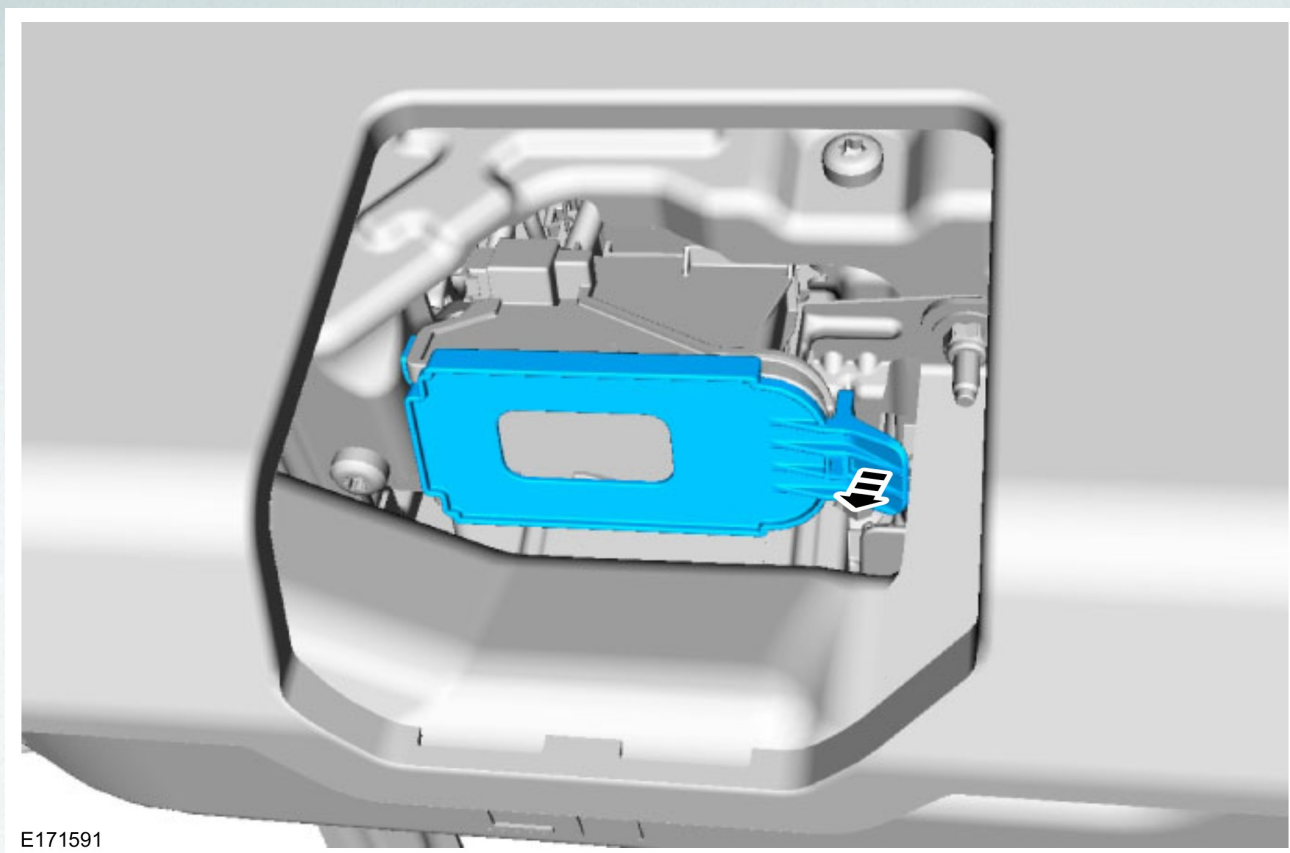

E171591

4. Den HOCHVOLT-SERVICESTECKER abziehen.

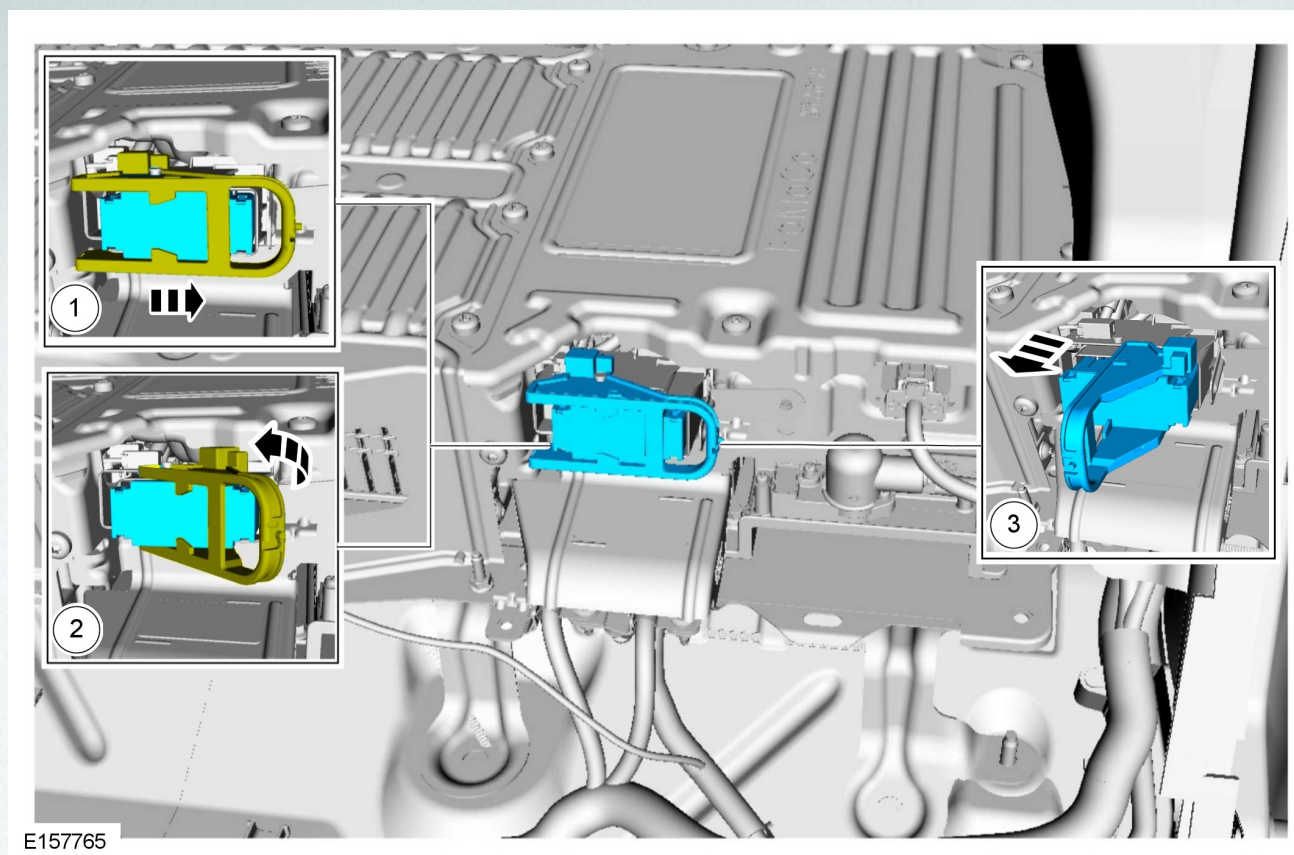

E157765

(Stand : 02/2017)

FORD Mustang

Cabrio

03/2015 – >

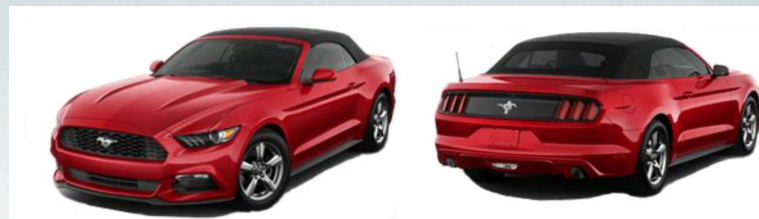

E204908

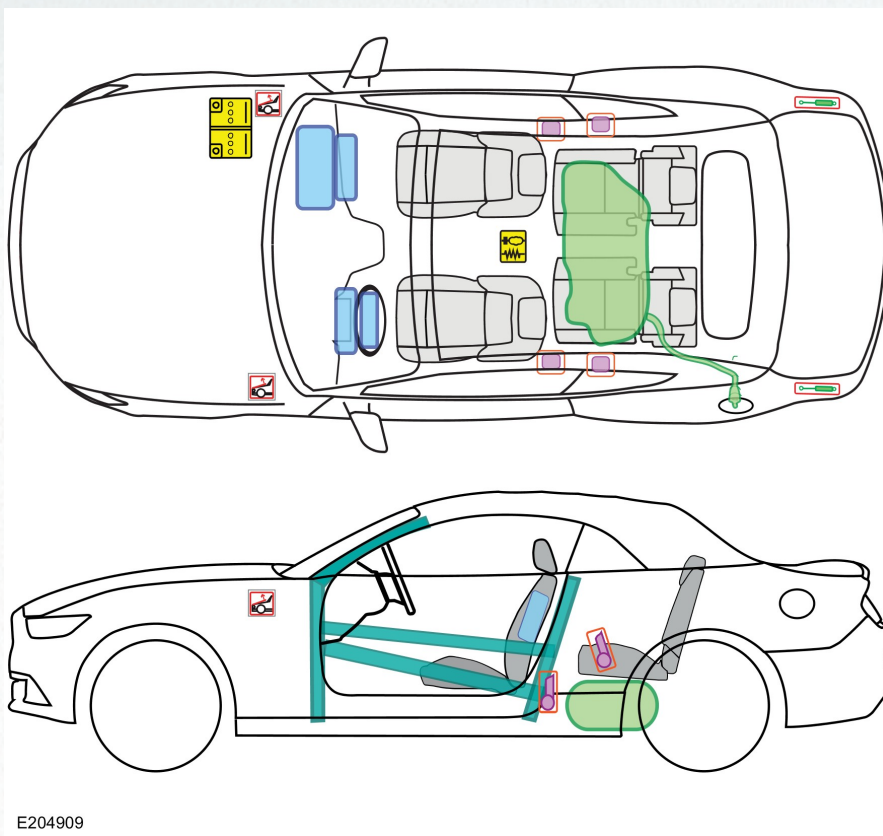

E204909

Legende

M

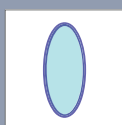

Airbag

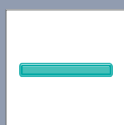

Karosseriever-
stärkung



Steuergerät



Fussgänger-
schutzsystem

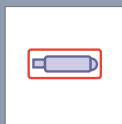

Gasgenerator

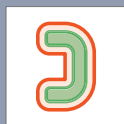

Überrollschutz-
bügel

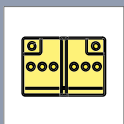

Batterie

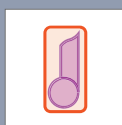

Gurtstraffer

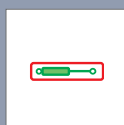

Gasdruck-
dämpfer



Kraftstofftank

(Stand : 03/2017)

FORD Mustang

Coupé

03/2015 – >



E204875

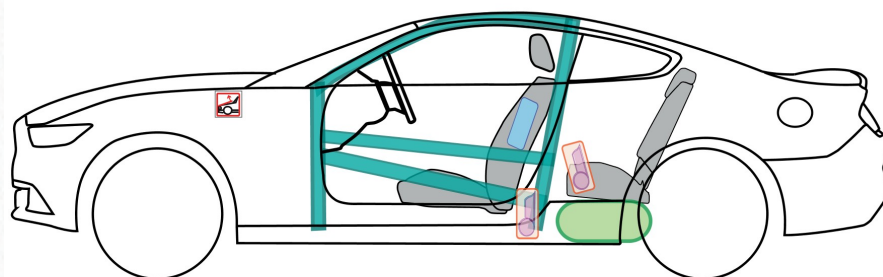
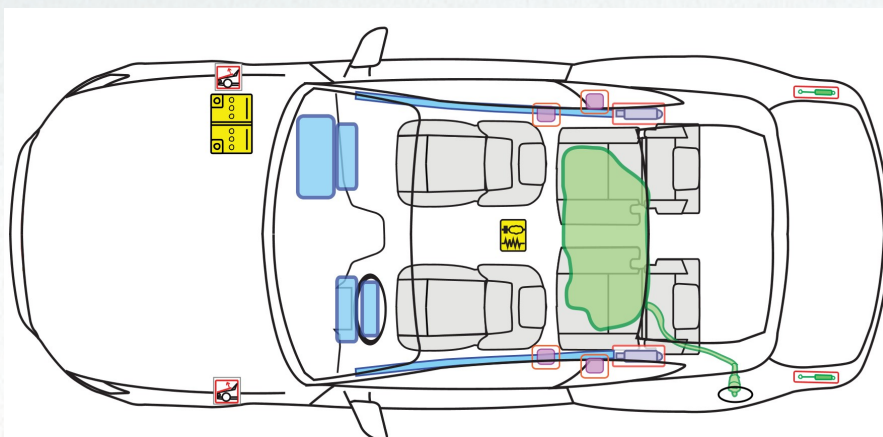

E204876

Legende

M

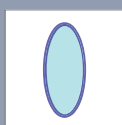

Airbag

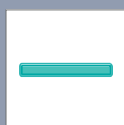

Karosseriever-
stärkung



Steuergerät



Fussgänger-
schutzsystem



Gasgenerator



Überrollschutz-
bügel

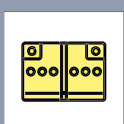

Batterie

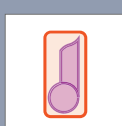

Gurtstraffer

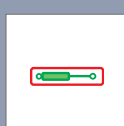

Gasdruck-
dämpfer



Kraftstofftank

(Stand : 03/2017)



FORD Puma

10/2019 – >



E321481

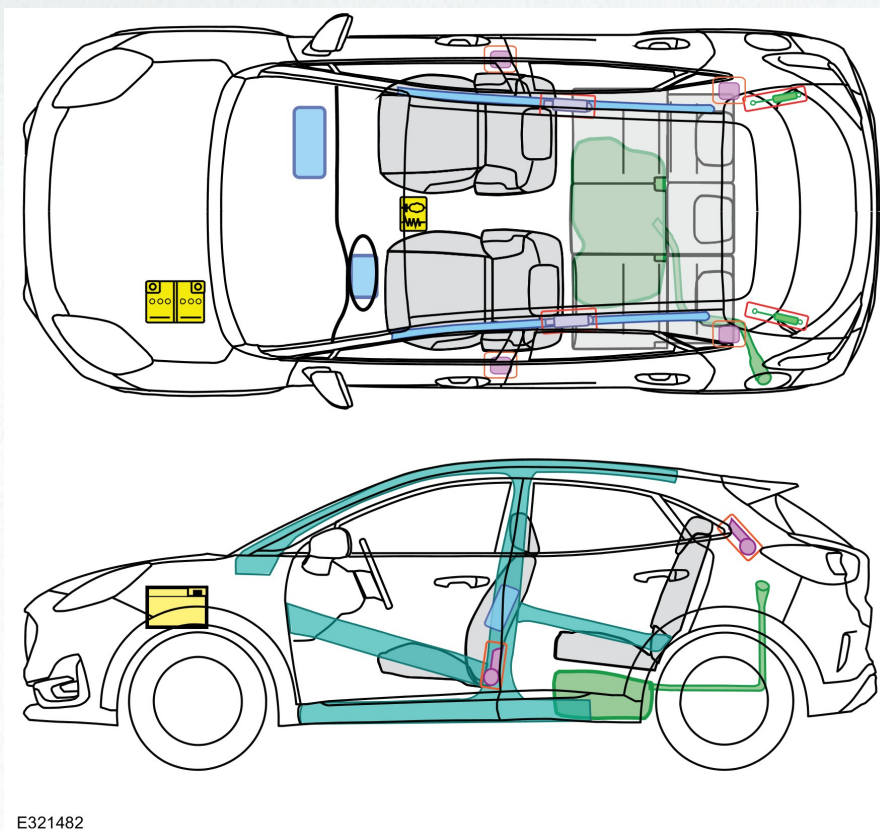

E321482

Legende

P

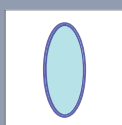

Airbag

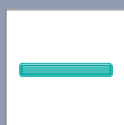

Karosseriever-
stärkung



Steuergerät



Fussgänger-
schutzsystem

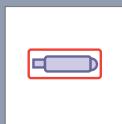

Gasgenerator



Überrollschutz-
bügel

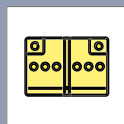

Batterie

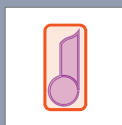

Gurtstraffer

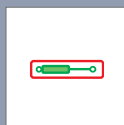

Gasdruck-
dämpfer



Kraftstofftank

(Stand : 11/2019)

FORD Puma mHEV



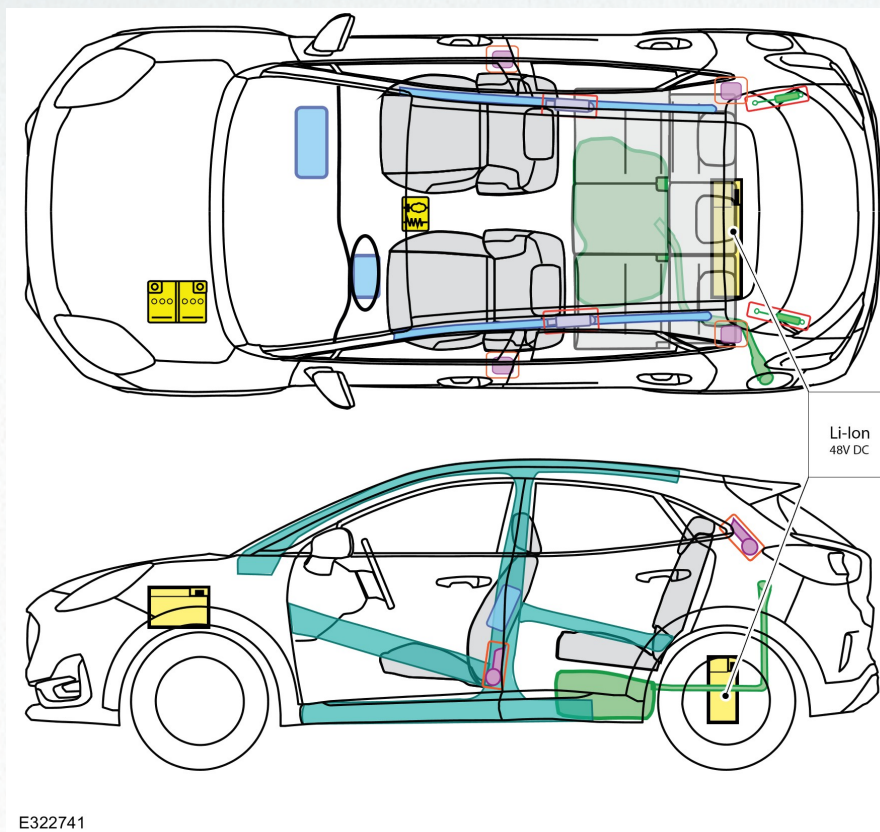



1.0L EcoBoost (92kW/125PS) (B7),
1.0L EcoBoost (114kW/155PS) (BZ)

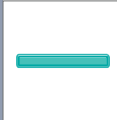

E322741

Legende

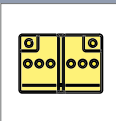
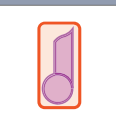
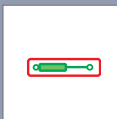
P

	Airbag		Karosseriever- stärkung		Steuergerät		Fussgänger- schutzsystem
	Gasgenerator		Überrollschutz- bügel		Batterie		
	Gurtstraffer		Gasdruck- dämpfer		Kraftstofftank		

(Stand : 11/2019)

FORD Puma mHEV

1.0L EcoBoost (92kW/125PS) (B7),
1.0L EcoBoost (114kW/155PS) (BZ)

04/2020 – >

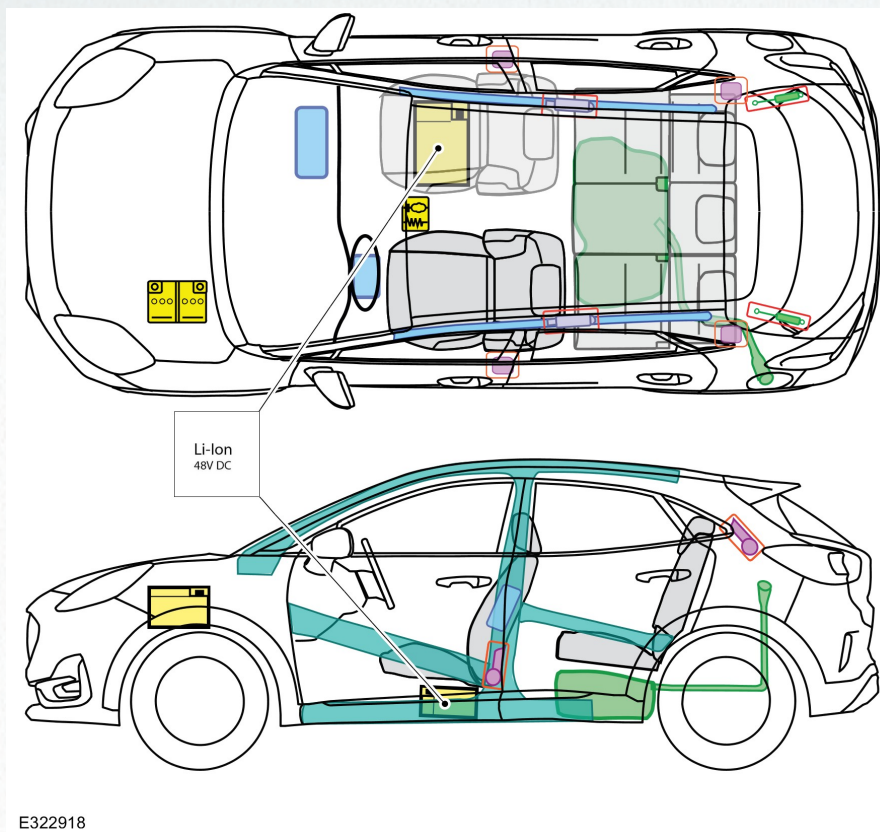

E322918

Legende

P

	Airbag		Karosserieverstärkung		Steuergerät		Fussgängerschutzsystem
	Gasgenerator		Überrollschutzbügel		Batterie		
	Gurtstraffer		Gasdruckdämpfer		Kraftstofftank		

(Stand : 11/2019)

FORD Ranger

06/2006 – 07/2011

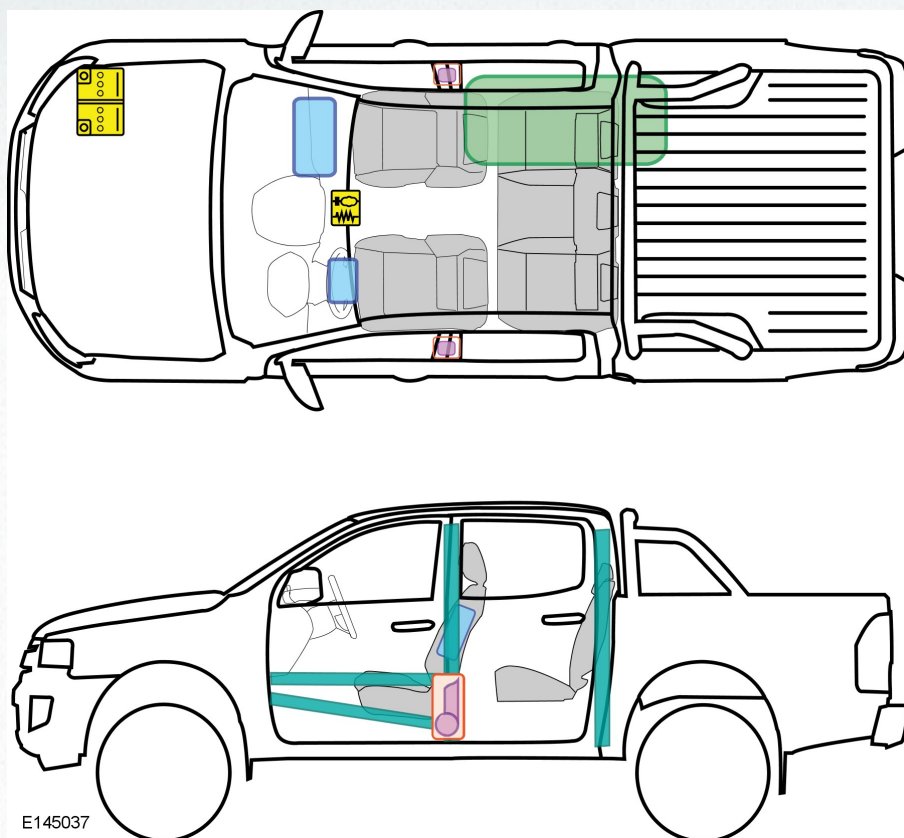

E145037

Legende

R

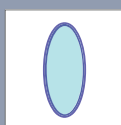

Airbag

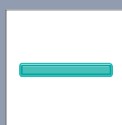

Karosseriever-
stärkung



Steuergerät



Fussgänger-
schutzsystem

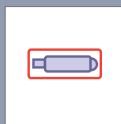

Gasgenerator



Überrollschutz-
bügel

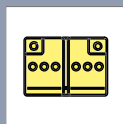

Batterie

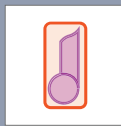

Gurtstraffer

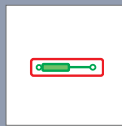

Gasdruck-
dämpfer

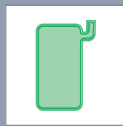

Kraftstofftank

(Stand : 01/2012)

FORD Ranger

07/2011 – >

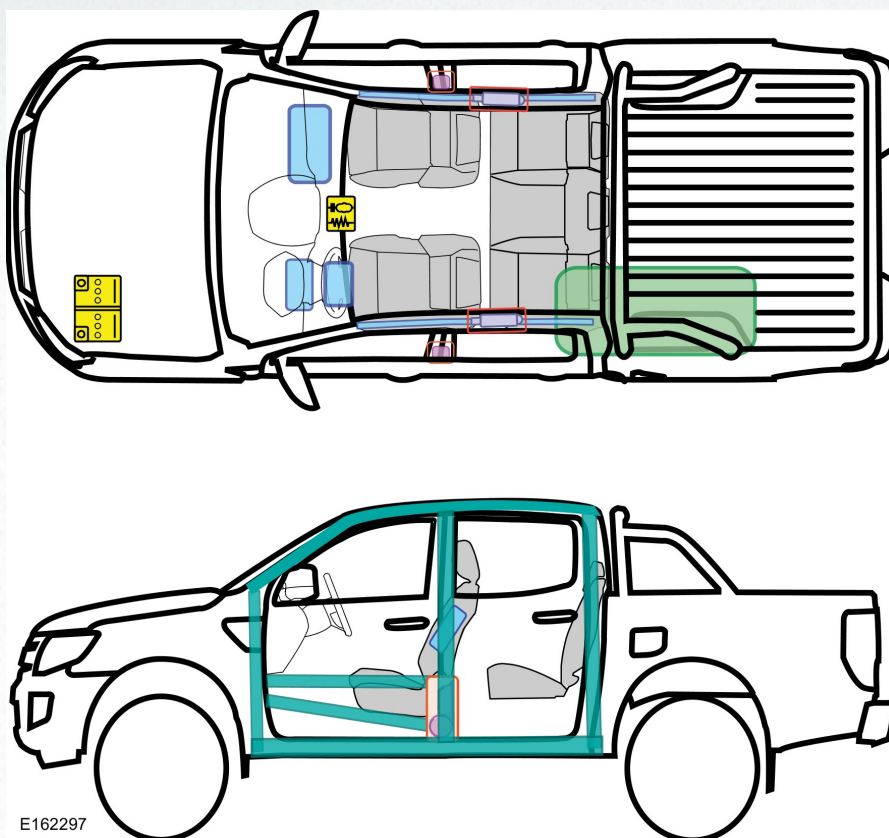

E162297

Legende

R

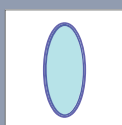

Airbag

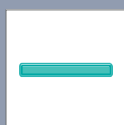

Karosseriever-
stärkung



Steuergerät



Fussgänger-
schutzsystem



Gasgenerator

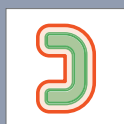

Überrollschutz-
bügel

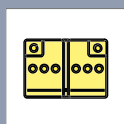

Batterie

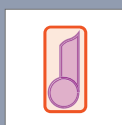

Gurtstraffer

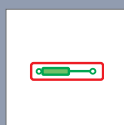

Gasdruck-
dämpfer



Kraftstofftank

(Stand : 01/2016)

FORD S-MAX



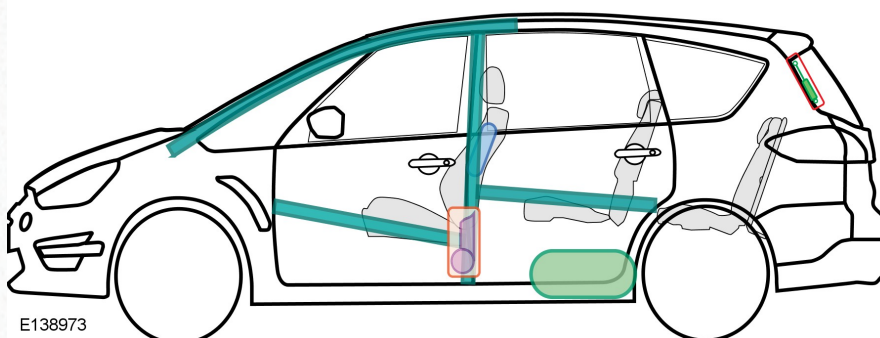
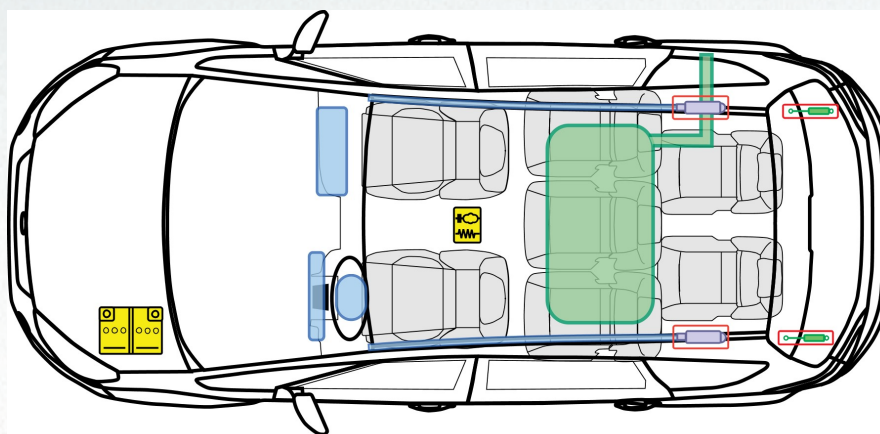



02/2006 – 05/2015

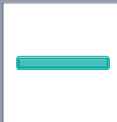

E138973

Legende

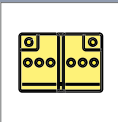
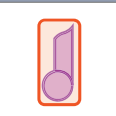
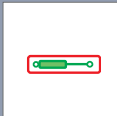
S

	Airbag		Karosseriever- stärkung		Steuergerät		Fussgänger- schutzsystem
	Gasgenerator		Überrollschutz- bügel		Batterie		
	Gurtstraffer		Gasdruck- dämpfer		Kraftstofftank		

(Stand : 06/2015)

FORD S-MAX

5-Türer SAV



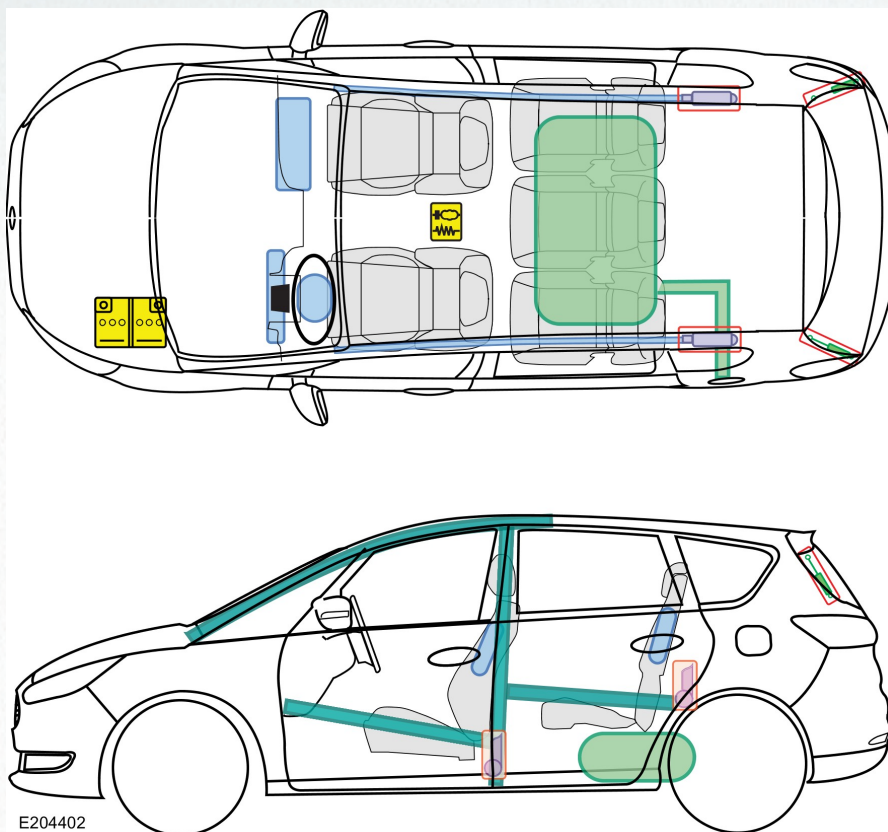



05/2015 – >

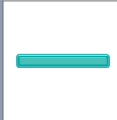

E204402

Legende

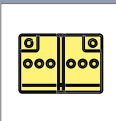
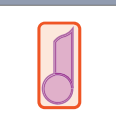
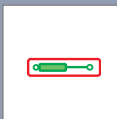
S

	Airbag		Karosseriever- stärkung		Steuergerät		Fussgänger- schutzsystem
	Gasgenerator		Überrollschutz- bügel		Batterie		
	Gurtstraffer		Gasdruck- dämpfer		Kraftstofftank		

(Stand : 06/2015)

FORD **Streetka**

Cabrio

01/2003 – 07/2005

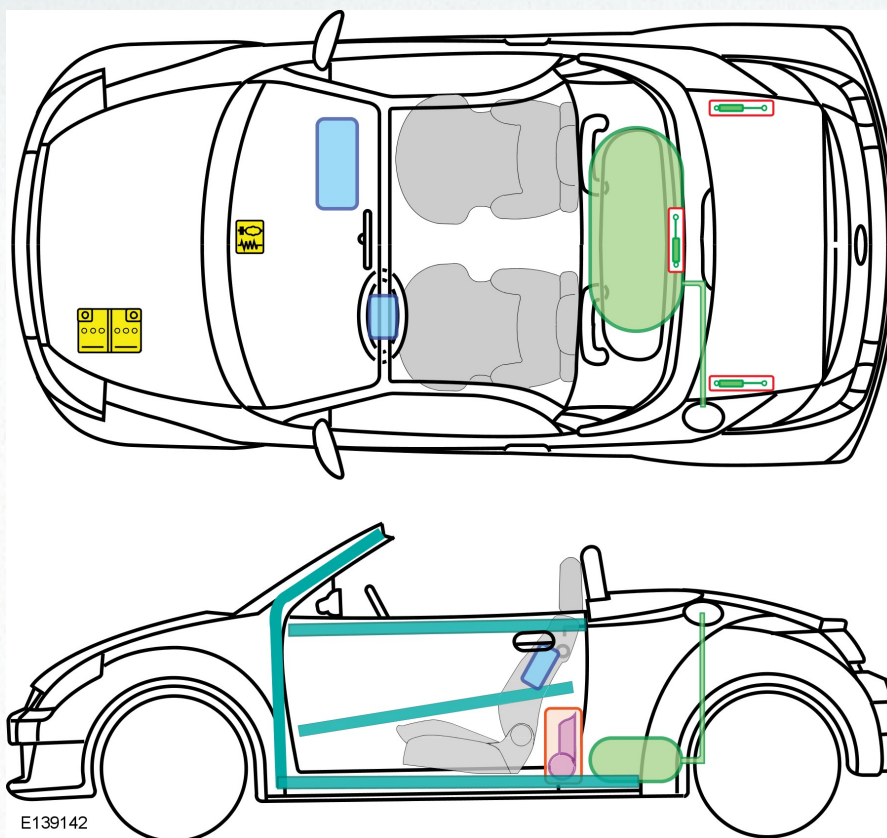

E139142

Legende

S

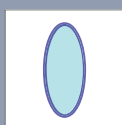

Airbag

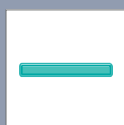

Karosseriever-
stärkung



Steuergerät



Fussgänger-
schutzsystem

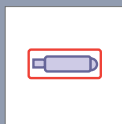

Gasgenerator



Überrollschutz-
bügel

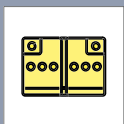

Batterie

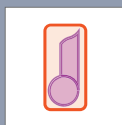

Gurtstraffer

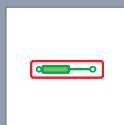

Gasdruck-
dämpfer



Kraftstofftank

(Stand : 03/2011)

FORD **Tourneo Connect**

09/2013 – >

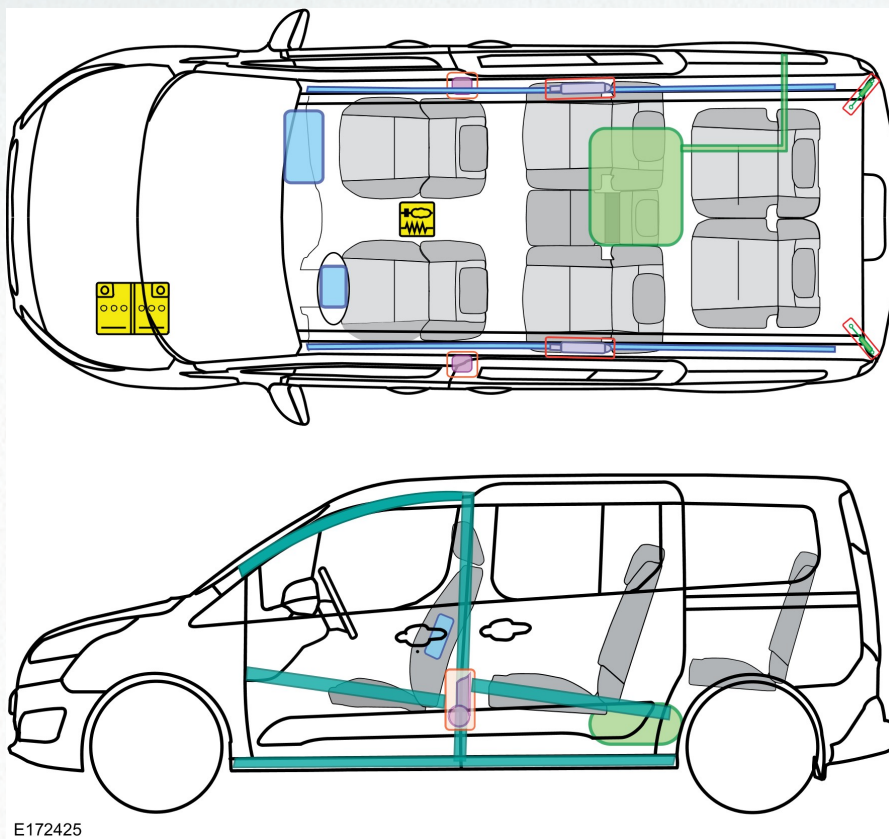

E172425

Legende

T

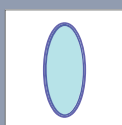

Airbag

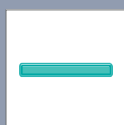

Karosseriever-
stärkung



Steuergerät



Fussgänger-
schutzsystem



Gasgenerator

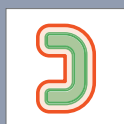

Überrollschutz-
bügel

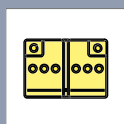

Batterie

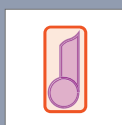

Gurtstraffer

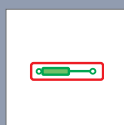

Gasdruck-
dämpfer



Kraftstofftank

(Stand : 09/2013)

FORD **Tourneo Connect**



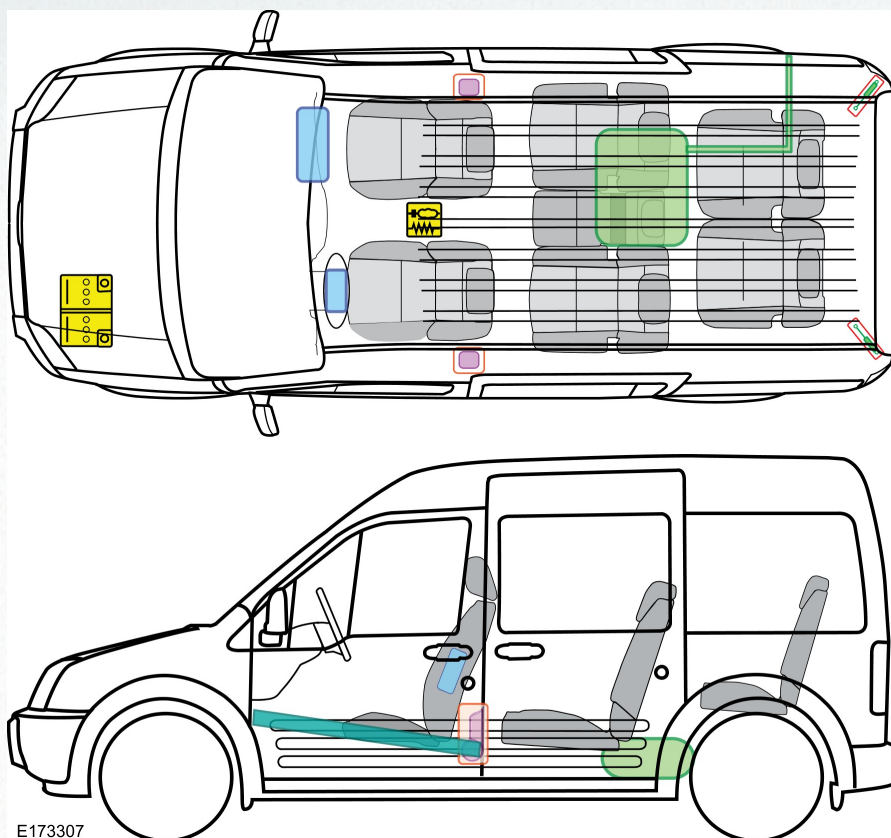



06/2002 – 07/2013

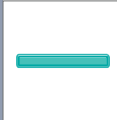

E173307

Legende

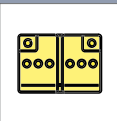
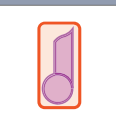
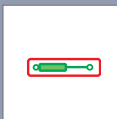
T

	Airbag		Karosseriever- stärkung		Steuergerät		Fussgänger- schutzsystem
	Gasgenerator		Überrollschutz- bügel		Batterie		
	Gurtstraffer		Gasdruck- dämpfer		Kraftstofftank		

(Stand : 09/2013)

FORD **Tourneo Courier**

03/2014 – >

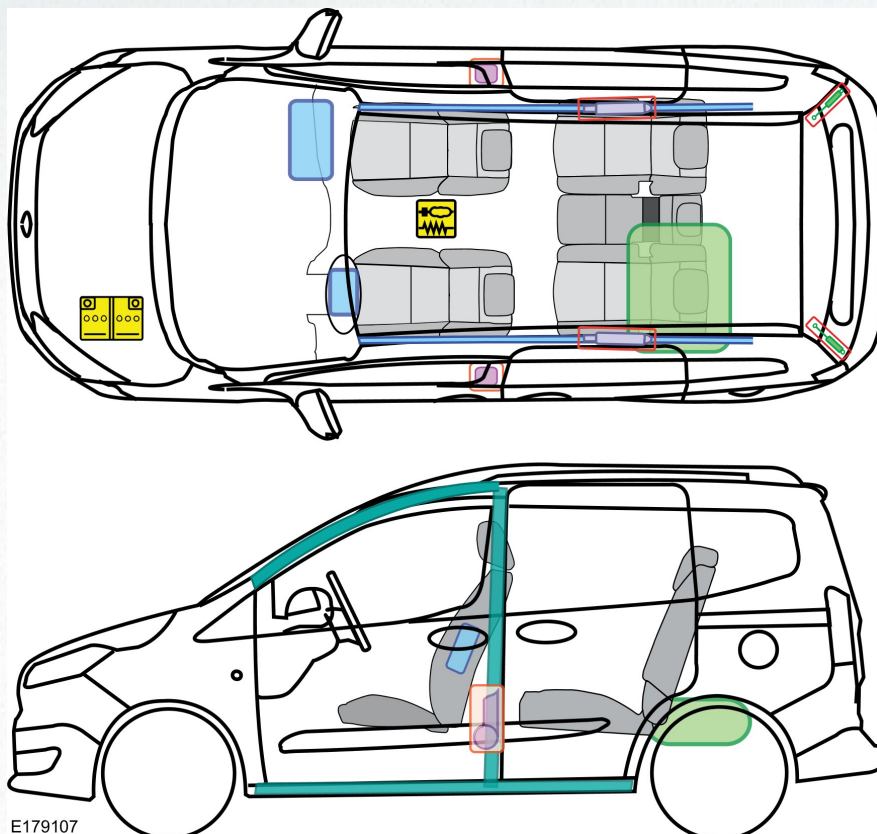

E179107

Legende

T

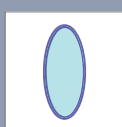

Airbag

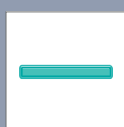

Karosseriever-
stärkung



Steuergerät



Fussgänger-
schutzsystem



Gasgenerator

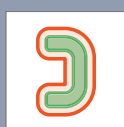

Überrollschut-
bügel

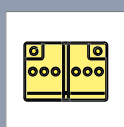

Batterie

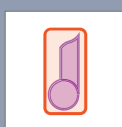

Gurtstraffer

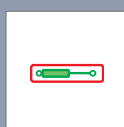

Gasdruck-
dämpfer



Kraftstofftank

(Stand : 01/2014)

FORD **Tourneo Custom**



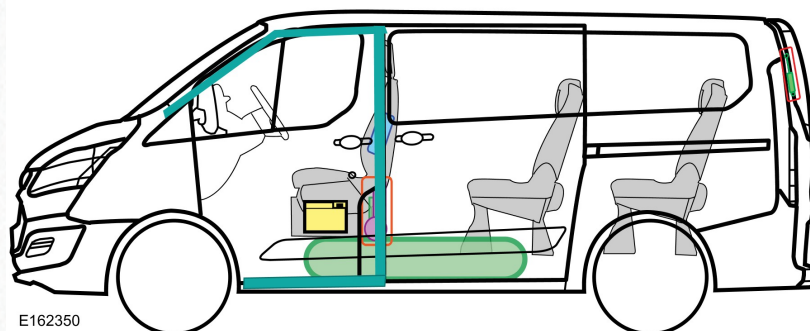
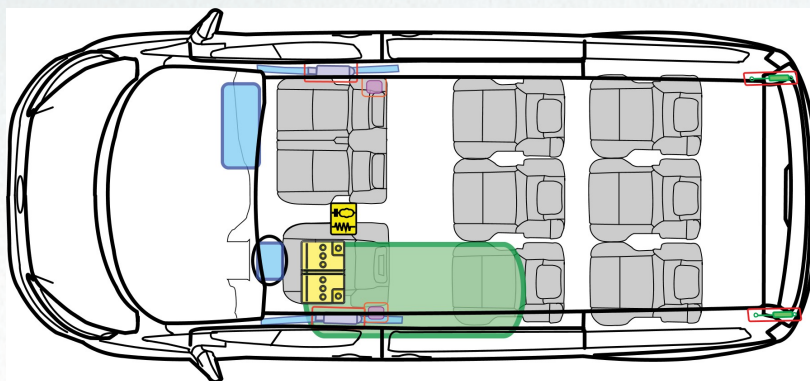



07/2012 – >

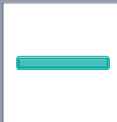

E162350

Legende

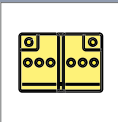
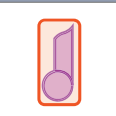
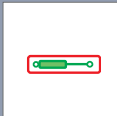
T

	Airbag		Karosseriever- stärkung		Steuergerät		Fussgänger- schutzsystem
	Gasgenerator		Überrollschutz- bügel		Batterie		
	Gurtstraffer		Gasdruck- dämpfer		Kraftstofftank		

(Stand : 02/2014)

FORD Transit 2014.5

M2 Bus

08/2013 – >

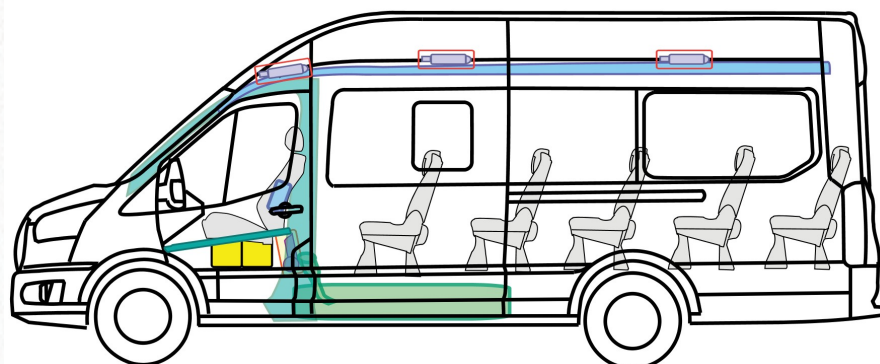
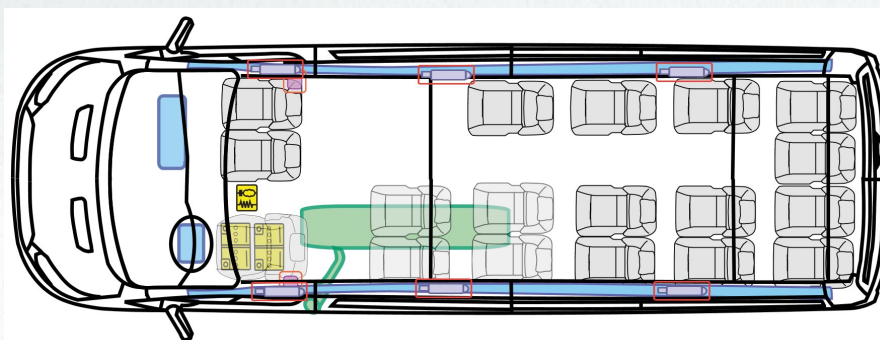

E291598

Legende

T

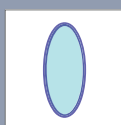

Airbag

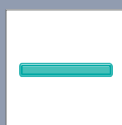

Karosseriever-
stärkung



Steuergerät



Fussgänger-
schutzsystem

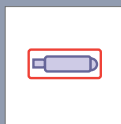

Gasgenerator



Überrollschutz-
bügel

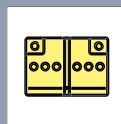

Batterie

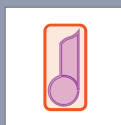

Gurtstraffer

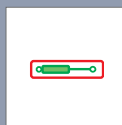

Gasdruck-
dämpfer



Kraftstofftank

(Stand : 01/2019)

FORD Transit 2014.5

Einzelkabine ohne Aufbau

08/2013 – >

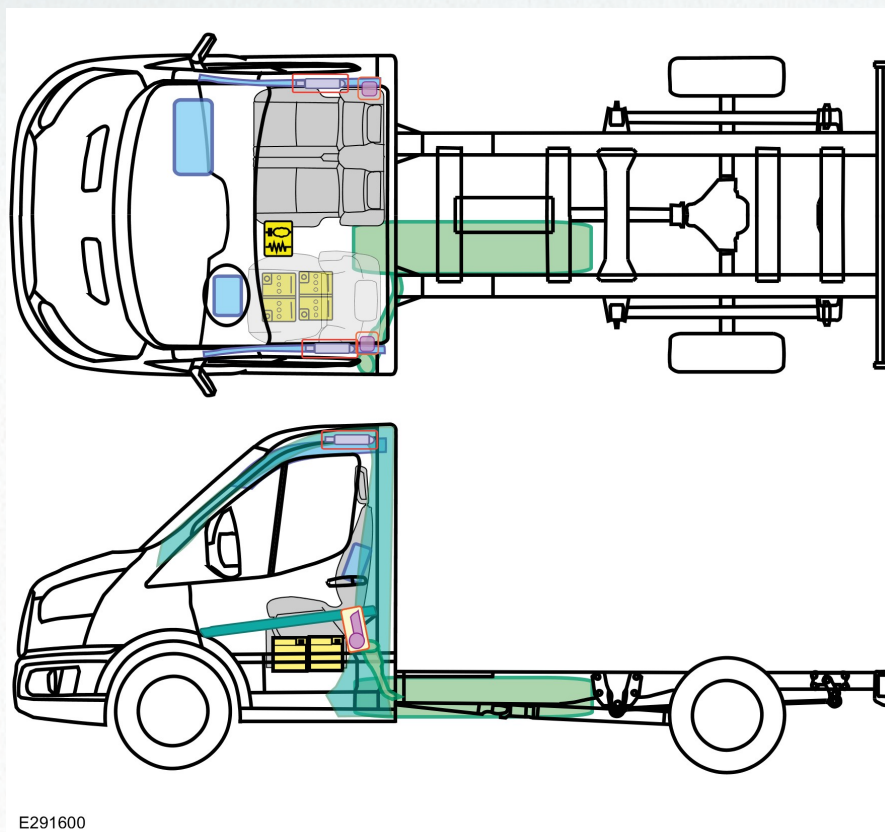

E291600

Legende

T

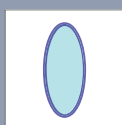

Airbag

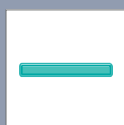

Karosseriever-
stärkung



Steuergerät



Fussgänger-
schutzsystem

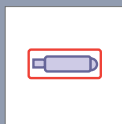

Gasgenerator



Überrollschutz-
bügel

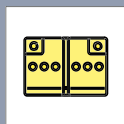

Batterie

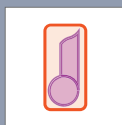

Gurtstraffer

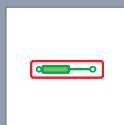

Gasdruck-
dämpfer

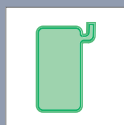

Kraftstofftank

(Stand : 01/2019)

FORD Transit 2014.5

Doppelkabine ohne Aufbau

08/2013 – >

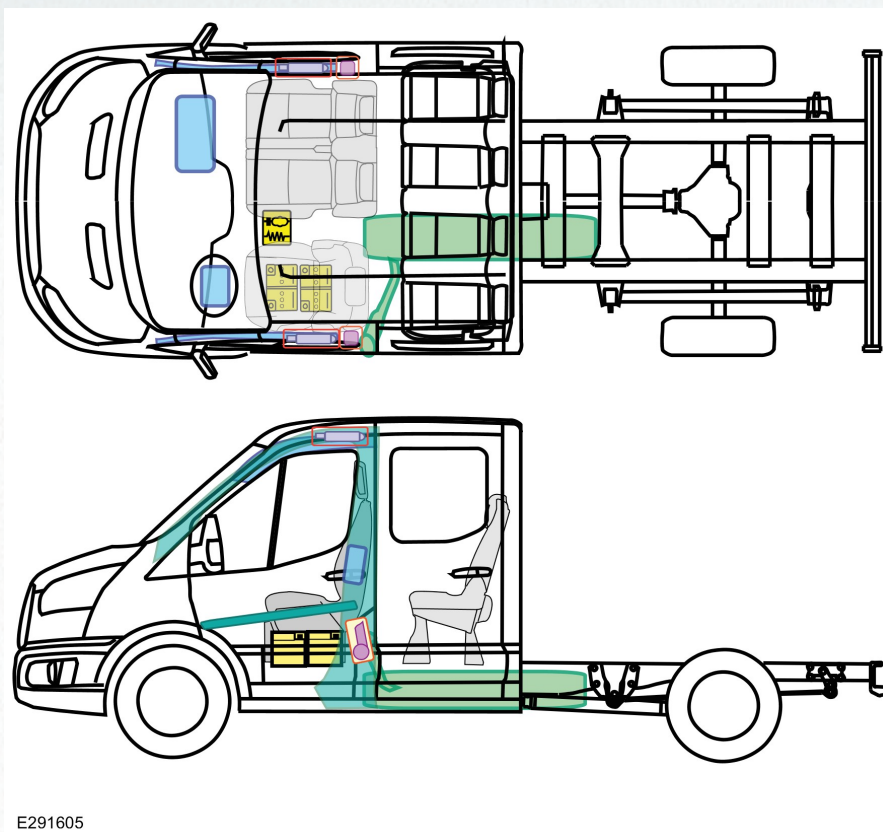

Legende

T

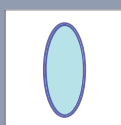

Airbag

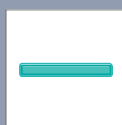

Karosseriever-
stärkung



Steuergerät



Fussgänger-
schutzsystem

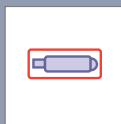

Gasgenerator



Überrollschutz-
bügel

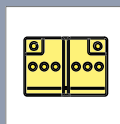

Batterie

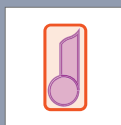

Gurtstraffer

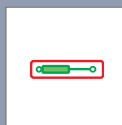

Gasdruck-
dämpfer



Kraftstofftank

(Stand : 01/2019)

FORD Transit 2014.5

Kastenwagen

08/2013 – >

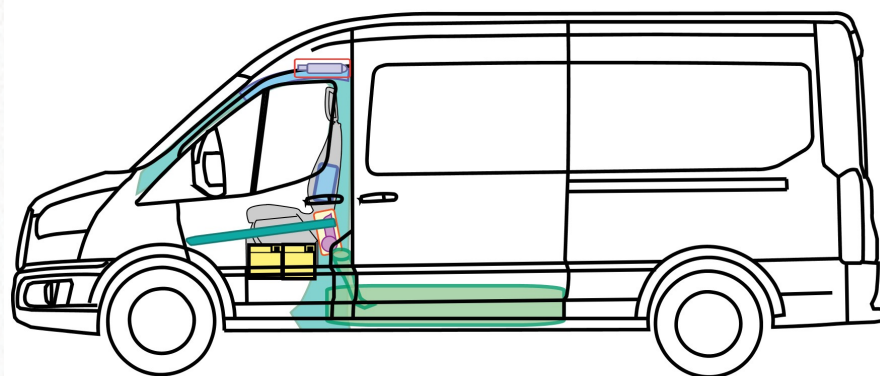
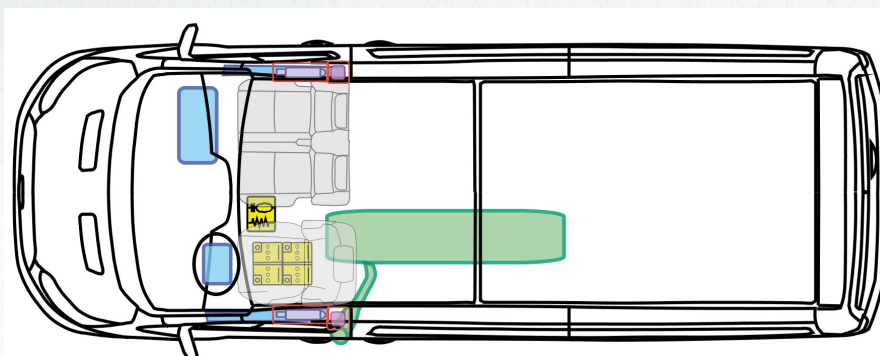

E291602

Legende

T

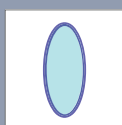

Airbag

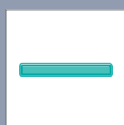

Karosseriever-
stärkung



Steuergerät



Fussgänger-
schutzsystem

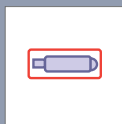

Gasgenerator



Überrollschutz-
bügel

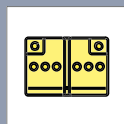

Batterie

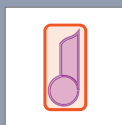

Gurtstraffer

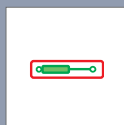

Gasdruck-
dämpfer



Kraftstofftank

(Stand : 01/2019)

FORD Transit 2014.5

NI Kombi

08/2013 – >

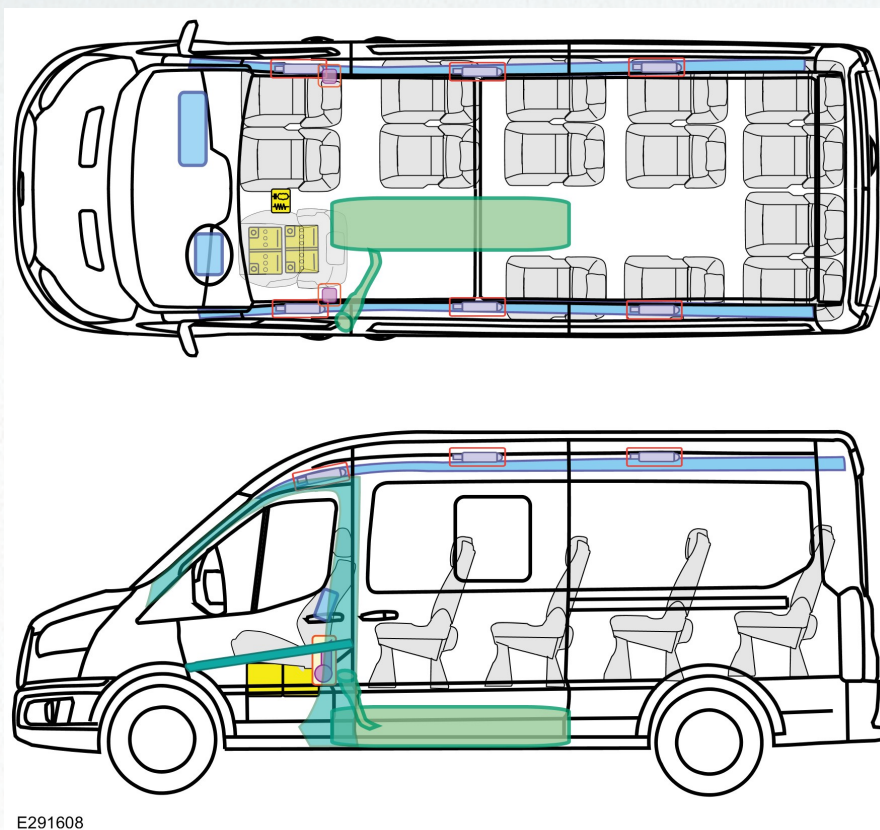

Legende

T

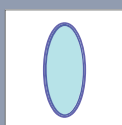

Airbag

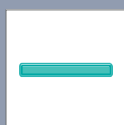

Karosseriever-
stärkung



Steuergerät



Fussgänger-
schutzsystem

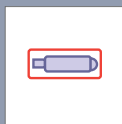

Gasgenerator



Überrollschutz-
bügel

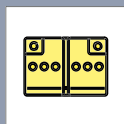

Batterie

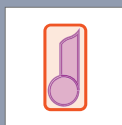

Gurtstraffer

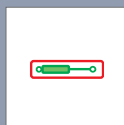

Gasdruck-
dämpfer



Kraftstofftank

(Stand : 01/2019)

FORD **Transit Connect**

Kastenwagen mit langem Radstand

02/2013 – >

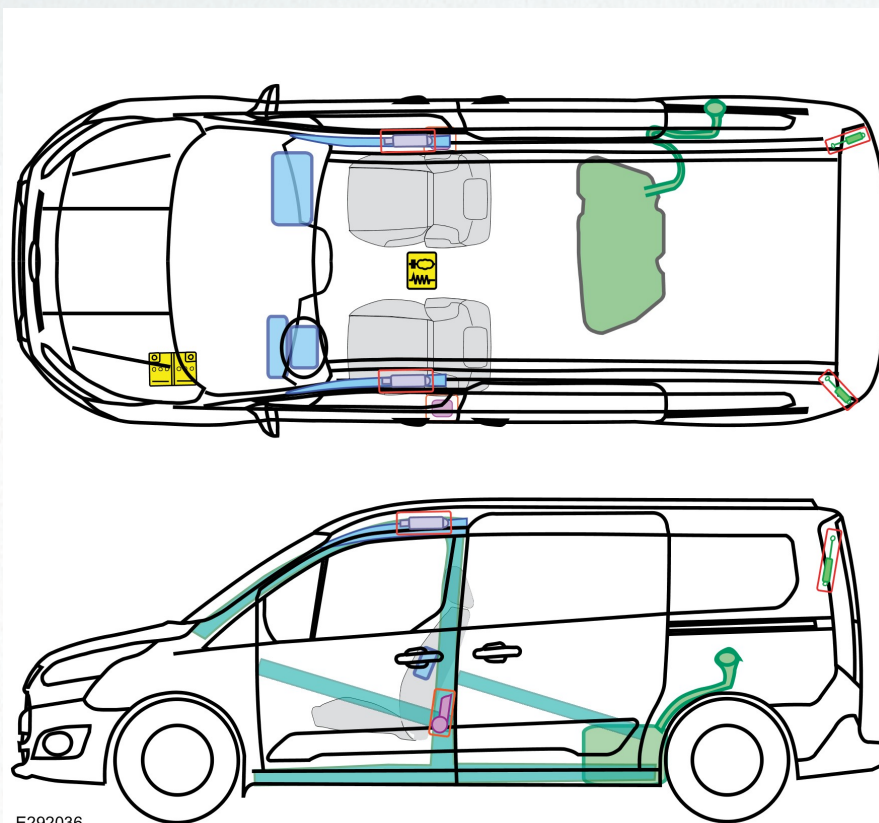

E292036

Legende

T

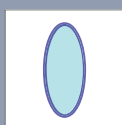

Airbag

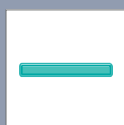

Karosseriever-
stärkung



Steuergerät



Fussgänger-
schutzsystem



Gasgenerator



Überrollschutz-
bügel

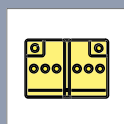

Batterie

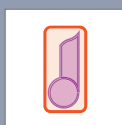

Gurtstraffer

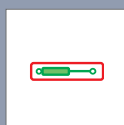

Gasdruck-
dämpfer



Kraftstofftank





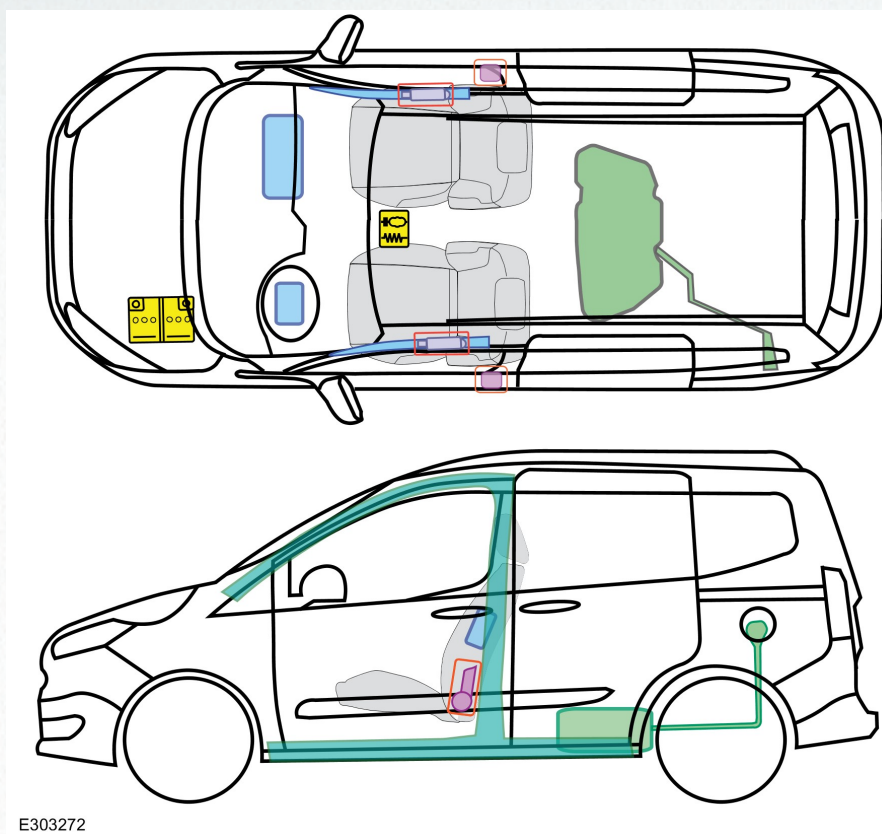

(Stand : 10/2018)

FORD Transit Courier

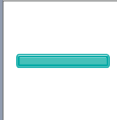

Legende

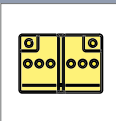
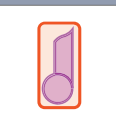
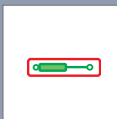
T

	Airbag		Karosserieverstärkung		Steuergerät		Fussgängerschutzsystem
	Gasgenerator		Überrollschutzbügel		Batterie		
	Gurtstraffer		Gasdruckdämpfer		Kraftstofftank		

(Stand : 03/2019)

FORD Transit Custom

07/2012 – >

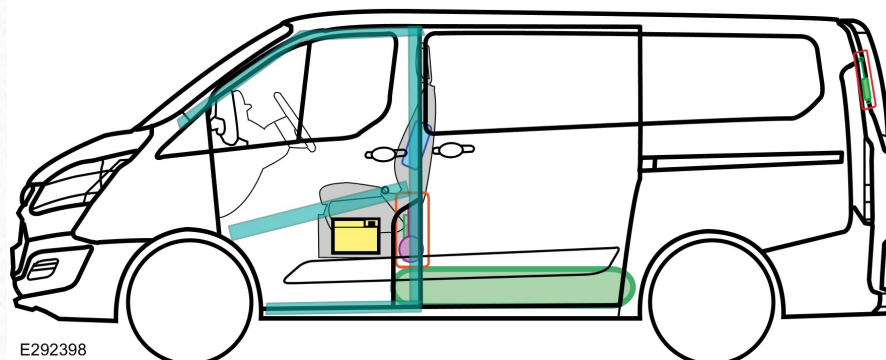
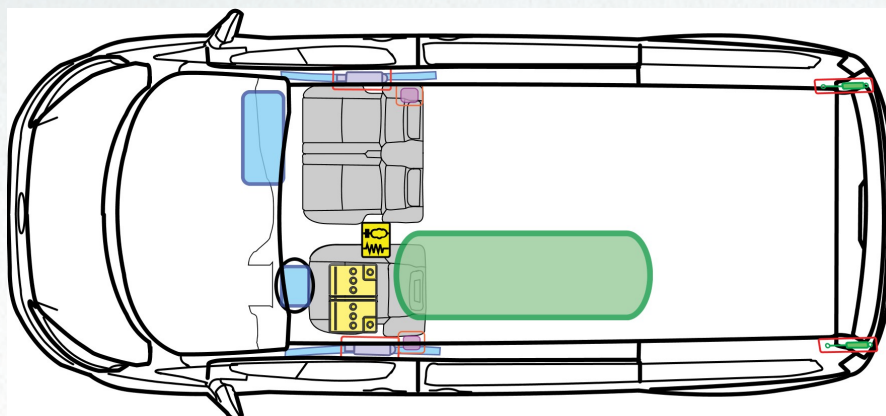

Legende

T

	Airbag		Karrossierverstärkung		Steuergerät		Fussgängerschutzsystem
	Gasgenerator		Überrollschutzbügel		Batterie		
	Gurtstraffer		Gasdruckdämpfer		Kraftstofftank		

(Stand : 10/2018)

FORD Transit Tourneo

08/2007 – >

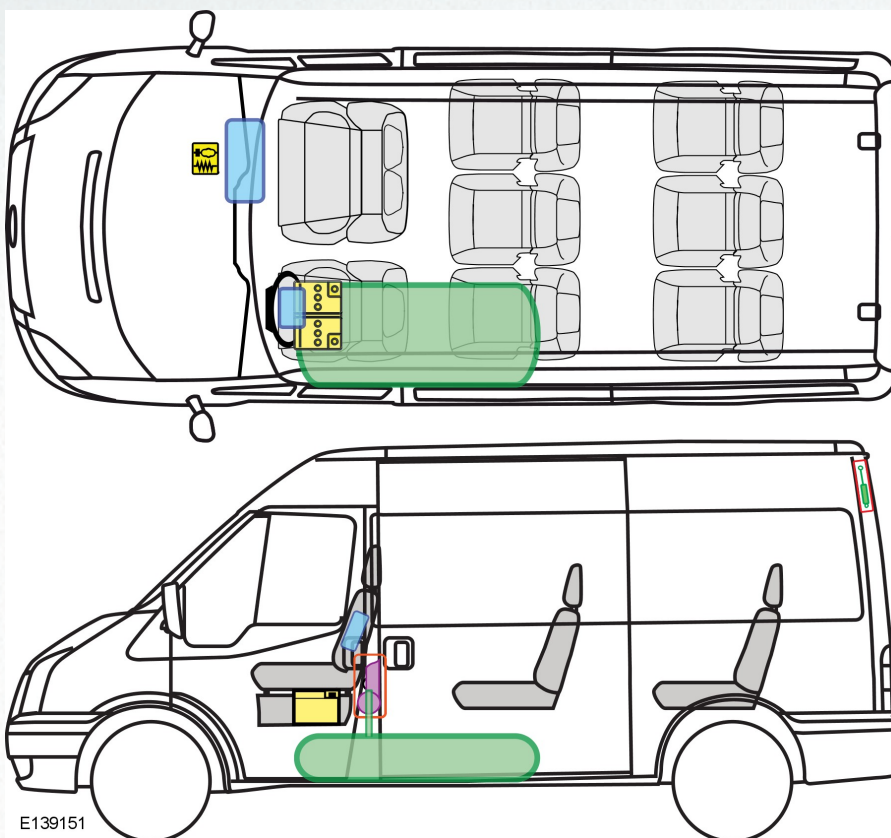

Legende

T

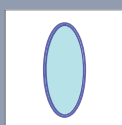

Airbag

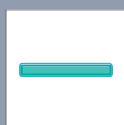

Karosseriever-
stärkung



Steuergerät



Fussgänger-
schutzsystem

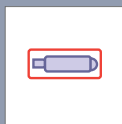

Gasgenerator



Überrollschutz-
bügel

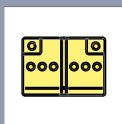

Batterie

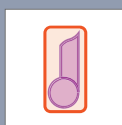

Gurtstraffer

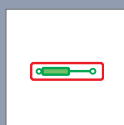

Gasdruck-
dämpfer



Kraftstofftank

(Stand : 03/2011)