

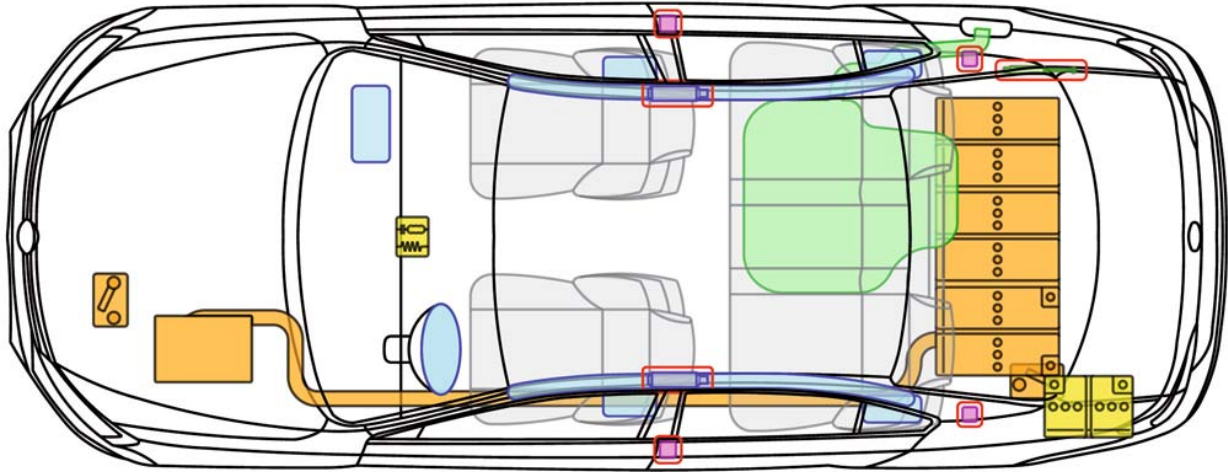

# Jetta

(Hybrid, ab 2012)







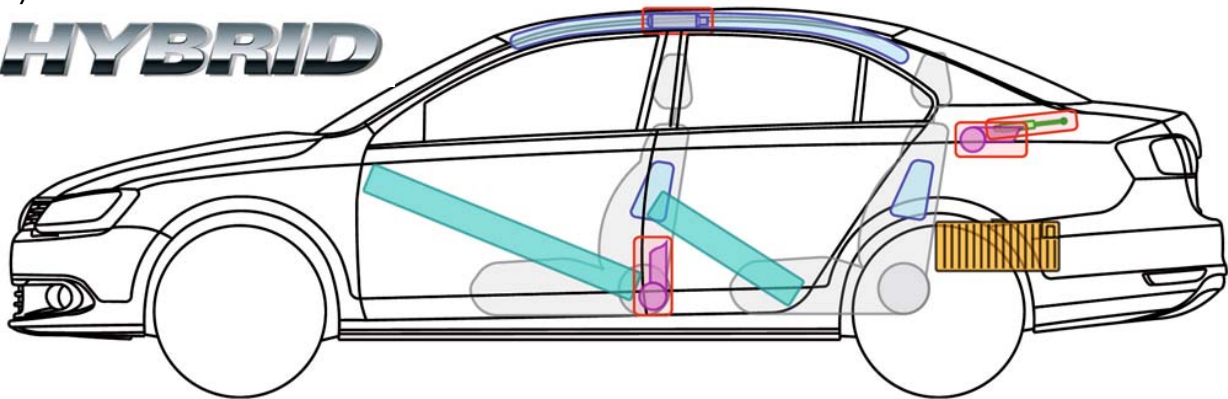





Hybridantrieb

## HYBRID



### Legende

	Airbag		Karosserie-Verstärkung		Steuergerät		Hochvolt-batterie
	Gas-generator				12V-Batterie		Hochvolt-leitung/-komponente
	Gurtstraffer		Gasdruck-dämpfer		Kraftstofftank		Trennstelle für Hochvolt



# Jetta

(Hybrid, ab 2012)



## Fahrzeugidentifizierung

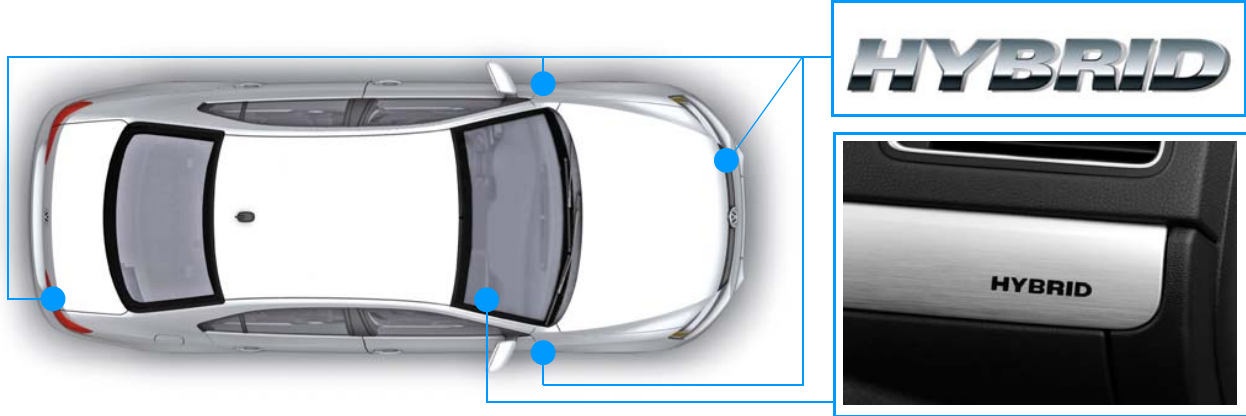

Designleiste Handschuhfach

## Fahrzeug gegen Wegrollen sichern

## Fahrzeug deaktivieren

### Antrieb und Hochvoltsystem deaktivieren (Zündung und 12V-Batterie zugänglich)

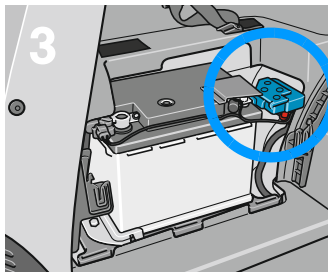

1. Zündschlüssel in „AUS-Stellung“ drehen oder
2. Start/Stop-Taster bis zur 2. Stufe durchdrücken oder
3. 12V-Batterie im Kofferraum links lokalisieren und abklemmen. Dabei beide Plusleitungen (rot) mit geeignetem Werkzeug abtrennen!



Werden nicht beide Plus-Leitungen getrennt, schaltet das Hochvoltsystem nicht sicher ab!  
Deshalb grundsätzlich immer beide Plus-Leitungen trennen!



# Jetta

(Hybrid, ab 2012)



## Fahrzeug deaktivieren

### Hochvoltsystem deaktivieren

(Zündung und 12V-Batterie NICHT zugänglich)

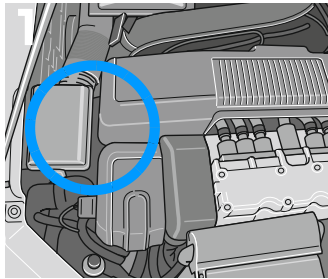

1. Zum Erreichen der gelb markierten Trennstelle im Motorraum die Designabdeckung des Motors entfernen.

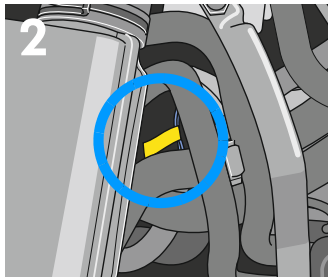

2. Gelb markierte Trennstelle lokalisieren

- Die zu trennende 12V-Leitung befindet sich auf Höhe des Luftfilters zwischen Kühler und Motorblock

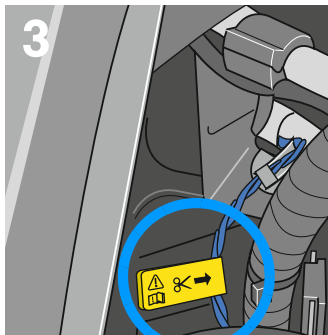

3. Leitung an der gelb markierten Trennstelle mit geeignetem Werkzeug durchschneiden.



Das Hochvoltsystem ist nach dem Deaktivieren innerhalb von ca. 20 Sekunden spannungsfrei. Die passiven Sicherheitssysteme wie Airbags und Gurtstraffer sind dann nicht deaktiviert.

J

Jetta Hybrid, ab 2012